

ITER TECHNICAL REPORT



china eu india japan korea russia usa

REPORT NO.

ITR-24-012

TITLE

**ITER Vacuum Handbook
Appendices and attachments**

AUTHOR/AUTHORS

R. Pearce, L. Worth

AUTHOR EMAIL(S)

liam.worth@iter.org

DATE

December 20th, 2024



The views and opinions expressed herein do not necessarily reflect those of the ITER Organization.

©2024, ITER Organization

www.iter.org



This work is licensed under the Creative Commons Attribution-NonCommercial-NoDerivs 3.0 IGO-ported license. (CC BY-NC-ND 3.0 IGO) You are free to share this work (copy, distribute and transmit) under the following conditions: you must give credit to the ITER Organization, you cannot use the work for commercial purposes and you cannot modify it. For a full copy of this license visit: <https://creativecommons.org/licenses/by-nc-nd/3.0/igo/>.

ITER Vacuum Handbook

Appendices and Attachments

Gourab Bansal, Bastien Boussier, Cyril Hume, Alan Kaye, Eamonn Quinn,
Robert Pearce, Ron Reid, Graeme Vine, Liam Worth, Michael Wykes.



This work is licensed under the Creative Commons Attribution-NonCommercial-NoDerivs 3.0 IGO-ported license (CC BY-NC-ND 3.0 IGO). You are free to share this work (copy, distribute and transmit) under the following conditions: you must give credit to the ITER Organization, you cannot use the work for commercial purposes and you cannot modify it. For a full copy of this license visit: <https://creativecommons.org/licenses/by-nc-nd/3.0/igo/>

Table of Contents

ITER Vacuum Handbook Appendix 1.....	1
1. Base Pressures and Expected Vacuum System Pumping Speed.....	1
1.1. Scope.....	1
1.2. Base Pressures.....	1
1.3. Pumping speeds for Cryopumps.....	2
1.4. Pumping speeds for roughing pumps.....	3
ITER Vacuum Handbook Appendix 2.....	4
2. Environmental Cleanliness requirements for Vacuum Quality Classification.....	4
2.1. Scope.....	4
2.2. Post Cleaning Handling of Vacuum Components.....	4
ITER Vacuum Handbook Appendix 3.....	6
3. ITER Approved Materials.....	6
3.1. Scope.....	6
3.2. Materials not on the Approved List.....	6
3.3. Material Selection / Qualification.....	6
3.4. Example Material Request Form.....	41
ITER Vacuum Handbook Appendix 4.....	42
4. ITER Accepted Fluids.....	42
4.1. Scope.....	42
4.2. Fluids not on the Accepted List.....	42
4.3. Fluid Selection / Qualification.....	43
ITER Vacuum Handbook Appendix 5.....	83
5. Acceptance Checklist.....	83
5.1. Scope.....	83
ITER Vacuum Handbook Appendix 6.....	105
6. Requirements for the Supply of Vacuum Windows.....	105
6.1. Scope.....	105
6.2. Design.....	105

6.3. Materials.....	106
6.3.1. Windows.....	106
6.3.2. Window (body) Assemblies.....	106
6.4. Manufacture.....	106
6.4.1. Welding of Window Assemblies.....	107
6.4.2. Bonding of Windows.....	107
6.4.2.1. VQC 1.....	107
6.4.2.2. VQC 2.....	107
6.5. Qualification of Windows (type testing).....	107
6.5.1. Pressure testing.....	108
6.5.2. Mechanical shock.....	108
6.5.3. Thermal Shock.....	108
6.5.4. Leak Testing.....	108
6.5.5. High Power RF Transmission.....	109
6.5.6. Voltage Stand-off.....	109
6.6. Testing and Inspection of Window Assemblies.....	109
6.6.1. Leak testing.....	109
6.7. Marking.....	110
6.8. Packaging & Delivery.....	110
6.9. Incoming inspection at the ITER Site.....	110
6.10. Documentation.....	110
ITER Vacuum Handbook Appendix 7.....	112
7. Requirements for the Supply and Modification of All-Metal Ultra High Vacuum Valves.....	112
7.1. Design.....	112
7.2. Additional requirements for the supply of standard valves with modified ends.....	113
7.2.1. Materials.....	113
7.2.1.1. General.....	113
7.2.1.2. Metallic Machined Components and Fittings.....	113

7.2.2. Fabrication.....	113
7.2.2.1. Welding.....	114
7.3. Leak Testing.....	114
7.4. Marking.....	115
7.5. Documentation.....	115
7.6. Packaging & Delivery.....	115
7.6.1. Incoming inspection at ITER Site.....	116
7.7. Documentation.....	116
ITER Vacuum Handbook Appendix 8.....	117
8. Flanges demountable.....	117
8.1. Terms and acronyms.....	117
8.2. Scope.....	117
8.3. Accepted Flange Set Combinations.....	118
8.3.1. Standard Flange Set DN (Nominal Diameter).....	118
8.3.2. Type of Flange Set.....	119
8.3.3. Flange Mounting / Demounting.....	121
8.3.4. Seal Material Type.....	121
8.3.5. Clamping Arrangement.....	124
8.4. Flange Set Manufacture.....	124
8.4.1. COTS Flange Sets.....	124
8.4.2. ITER Style Flange Set.....	124
8.4.3. Rectangular or Shaped Type Flange sets.....	125
8.5. References.....	128
ITER Vacuum Handbook Appendix 9.....	129
9. Guide to the Supply of Double Wall Vacuum Bellows.....	129
9.1. Scope.....	129
9.2. General.....	129
9.3. Design of bellows.....	129

9.4. Materials.....	130
9.4.1. General.....	130
9.4.2. Metallic Machined Components and Fittings.....	130
9.5. Manufacture.....	130
9.5.1. General.....	130
9.5.2. Welding of bellows assemblies.....	130
9.6. Qualification of Bellows (type testing).....	131
9.6.1. Pressure testing.....	131
9.6.2. Mechanical shock testing.....	131
9.6.3. Fatigue life tests.....	131
9.6.4. Leak Testing.....	132
9.7. Testing and Inspection of Bellows.....	132
9.7.1. Leak testing.....	133
9.7.2. Dimensional inspection.....	133
9.8. Cleaning.....	133
9.8.1. Procedure for Bellows for Class VQC 1 use.....	133
9.9. Proprietary bellows.....	133
9.10. Bellows Protection.....	134
9.11. Marking.....	134
9.12. Packaging & delivery.....	134
9.13. Documentation.....	135
ITER Vacuum Handbook Appendix 10.....	136
10. Requirements for the Supply of In-Vacuum Cables.....	136
10.1. General.....	136
10.2. Mineral Insulated cable (MI).....	137
10.3. Metal braided fibre insulated cable.....	138
10.4. Other cables.....	138
10.5. Connectors and Terminations.....	139

10.6. Cable Routing.....	139
10.7. References.....	139
ITER Vacuum Handbook Appendix 11.....	140
11. Standard Vacuum Pipe and Pipe Fitting Dimensions.....	140
11.1. Introduction.....	140
11.2. Scope.....	140
11.3. Dimensions.....	140
11.3.1. Standard Pipe.....	140
11.3.2. Standard Pipe Fittings.....	140
11.4. Weld Preparation.....	140
11.5. Bibliography.....	141
ITER Vacuum Handbook Appendix 12.....	147
12. Guide to Leak Testing of Components.....	147
12.1. Scope and Status.....	147
12.2. General.....	147
12.3. Leak testing Methodologies.....	148
12.3.1. Over Pressure Methods.....	148
12.3.1.1. Mass Spectrometer Sniffing Probe.....	148
12.3.1.2. Probe Leak Testing (vacuum box or suction cup method).....	148
12.3.1.3. Pressurization ... Evacuation (•bombingŽ) Test.....	149
12.3.2. Vacuum Leak Detection Methods.....	149
12.3.2.1. Pressure Rise Test.....	149
12.3.2.2. Helium Leak Detectors.....	149
12.4. Procedure for Helium Leak Tightness and Testing.....	150
12.4.1. Equipment.....	150
12.4.2. Pumping System.....	150
12.4.2.1. Detection System.....	151
12.4.2.2. Miscellaneous.....	152

12.4.3. Preliminaries.....	152
12.4.3.1. Initial Checks on the Leak Detection System.....	152
12.4.3.2. Pump-down.....	152
12.4.3.3. Background Determination.....	153
12.4.4. Leak Detector Calibration.....	153
12.4.4.1. Response and Cleanup Time Measurement.....	153
12.4.5. Cold Leak Tests.....	154
12.4.5.1. Global Leak Check.....	154
12.4.5.2. Probe Tests.....	155
12.4.5.3. Acceptance Criteria.....	156
12.4.6. Hot Leak Check.....	156
12.4.6.1. Test Conditions.....	156
12.4.6.2. Global Leak Check with the Component under test Hot.....	157
12.4.6.3. Probe Test.....	157
12.4.6.4. Final Cold Acceptance Check.....	158
12.4.6.5. Acceptance Criteria.....	158
12.5. Responsibilities.....	158
12.6. Reporting.....	158
ITER Vacuum Handbook Appendix 13.....	160
13. Guide to Cleaning and Cleanliness for the Vacuum Components.....	160
13.1. Scope.....	160
13.2. General Cleaning Requirements.....	160
13.3. Health and Safety.....	160
13.4. Proprietary Items and Trademarks.....	161
13.5. Design Rules for Cleanability.....	161
13.6. Initial Inspection and Preparation.....	161
13.7. Mechanical Processes on Vacuum Surfaces.....	162
13.8. Use of acids.....	162

13.9. Treatment of Weld Burn.....	162
13.10. Electropolishing for VQC1 Applications.....	162
13.11. Handling and Packing.....	163
13.12. Spray washing.....	163
13.13. Standard Cleaning Procedure for Stainless Steel Components.....	164
13.13.1. Preclean.....	164
13.13.2. Wash.....	164
13.14. Chemical Clean for Stainless Steel for VQC 1 application.....	164
13.15. Chemical Clean for Stainless Steel for use on VQC 2, 3 & 4 components.	165
13.16. Chemical Clean for Copper and Copper Alloys.....	165
13.17. Cleaning Ceramics.....	165
13.18. Cleaning of Aluminium.....	165
13.19. Air Baking.....	166
13.20. •SnowŽ Cleaning.....	166
13.21. Cleaning Procedures for Vacuum Bellows.....	166
13.21.1. General.....	166
13.21.2. Procedure for Bellows for Class VQC 1 use.....	166
13.22. Cleanliness.....	167
13.22.1. Wipe Test for Cleanliness.....	167
13.22.1.1. Dry test.....	167
13.22.1.2. •WetŽ test.....	167
13.22.2. General Test for Cleanliness.....	168
13.23. Definition of Terms.....	170
ITER Vacuum Handbook Appendix 14.....	172
14. Guide to Passivation & Pickling for Steels and Copper.....	172
14.1. Scope of this Appendix.....	172
14.2. General Comments.....	172
14.3. Pickling and Passivation of Steels.....	172

14.4. Pickling and Passivation of Copper and Copper Alloys.....	174
14.5. Standards.....	174
ITER Vacuum Handbook Appendix 15.....	175
15. Guide for Vacuum Baking of Components.....	175
15.1. Scope.....	175
15.2. General Comments.....	175
15.3. General Procedures for Baking of Vacuum Items.....	176
15.3.1. Preliminary.....	176
15.3.2. Vacuum Pumps and Gauges.....	176
15.3.3. Temperature Monitoring and Control.....	177
15.3.4. Completing the Bake Process.....	177
15.4. Control of the Bake Process.....	177
15.5. Types of Bake Procedure.....	178
15.5.1. Total Immersion Bake.....	178
15.5.2. Oven Bake.....	178
15.5.3. •TapeŽ Bake.....	178
15.5.4. Air Bake.....	179
15.6. Documentation to be Supplied.....	179
ITER Vacuum Handbook Appendix 16.....	180
16. Guide to the Conditioning Carbon Composites.....	180
16.1. Scope.....	180
16.2. Procedures.....	180
16.2.1. Procedure for high temperature baking.....	180
16.2.2. Procedure for lower temperature baking.....	180
ITER Vacuum Handbook Appendix 17.....	182
17. Guide to Outgassing Rates and their Measurement.....	182
17.1. Scope.....	182
17.2. Limitations.....	182

17.3. Specific Outgassing Rate.....	183
17.4. Generic Methods of Measuring Outgassing Rates.....	183
17.4.1. Rate of Rise of Pressure Method.....	183
17.4.2. Dynamic Flow (Conductance) Method.....	184
17.4.3. Variant Dynamic Flow Methods.....	185
17.4.4. Weight Loss Method.....	185
17.5. Sources of Errors in Measuring Outgassing.....	185
17.5.1. System Effects.....	185
17.5.1.1. Vacuum Vessels and Conductance•s.....	185
17.5.1.2. Vacuum Gauges.....	186
17.5.1.3. Vacuum Pumps.....	186
17.5.1.4. Temperature.....	186
17.5.2. Gas Sources and Sinks.....	186
17.5.2.1. General Types of Gas Source or Sink.....	186
17.5.2.2. Surfaces as Sources.....	186
17.5.2.3. Surfaces as Sinks.....	187
17.5.2.4. Joints.....	187
17.5.2.5. Leaks.....	188
17.5.2.6. Moving items.....	188
17.5.2.7. Gauges as Sources.....	188
17.5.2.8. Gauges as Pumps.....	188
17.5.3. Some Practical Considerations.....	188
17.5.3.1. Minimising Errors.....	188
17.5.3.2. Time Zero for outgassing.....	189
17.5.4. Stating Outgassing Requirements.....	190
17.5.4.1. Vessel or Component Acceptance Tests.....	190
17.5.4.2. Testing items, materials for acceptability procedures.....	191
17.6. Procedures.....	191

17.6.1. General.....	191
17.6.1.1. Start Time.....	191
17.6.1.2. Pump Set Conditioning.....	191
17.6.1.3. Vacuum Vessel Outgassing Measurements.....	191
17.6.1.4. Vacuum Component or Sample Outgassing Measurements.....	192
17.6.2. Rate of Pressure Rise Method.....	192
17.6.2.1. Equipment.....	192
17.6.2.2. Procedure.....	193
17.6.3. Dynamic Flow Method.....	193
17.6.3.1. Equipment.....	193
17.6.3.2. Procedures.....	194
17.6.3.2.1. Outgassing measurements on a vessel.....	194
17.6.3.2.2. Outgassing measurements on coupon samples.....	195
17.7. Presentation of Results.....	195
17.8. Derivation of the ITER Outgassing Rate Requirements.....	195
17.8.1. Vacuum Vessel.....	196
17.8.2. Cryostat.....	197
17.9. Outgassing Rates Review.....	199
17.9.1. Material thermal outgassing.....	199
17.9.2. Unbaked Stainless Steel.....	200
17.9.3. Baked Stainless Steel.....	200
17.9.4. Organic Material.....	200
17.10. Outgassing Rates - Published Data.....	201
17.10.1. Stainless Steel.....	201
17.10.2. Epoxies.....	203
17.11. References.....	203
ITER Vacuum Handbook Appendix 18.....	205
18. Vacuum component reliability data.....	205

18.1. Scope.....	205
18.2. Source data.....	206
18.3. Failure rates for major vacuum components.....	207
18.3.1. Failure rates for vacuum pumps.....	207
18.3.2. Failure rates for vacuum gauges.....	208
18.3.3. Failure rates for vacuum gate valves.....	208
18.3.4. Failure rates for standard fittings.....	208
18.4. Failure rates for bellows.....	209
18.5. Failure rates for metallic tubing and pipework.....	210
18.6. Other References.....	210
ITER Vacuum Handbook Appendix 19.....	211
19. Documentation and QA for Vacuum Quality Assurance.....	211
19.1. Scope of this Appendix.....	211
19.2. Areas to which Vacuum QA Applies.....	211
19.3. Supplier's QA System.....	211
19.4. Certificates.....	211
19.5. Materials Used.....	212
19.5.1. Information Normally Required Prior to Manufacture.....	212
19.5.2. Normal Post Manufacture Certification.....	212
19.6. Cleaning and Processing.....	212
19.6.1. Information Normally Required Prior to Manufacture.....	212
19.6.2. Normal Post Manufacture Certification.....	212
19.7. Assessment of Cleanliness.....	213
19.7.1. Information Normally Required Prior to Manufacture.....	213
19.7.2. Normal Post Manufacture Certification.....	213
19.8. Leak Tightness.....	213
19.8.1. Information Normally Required Prior to Manufacture.....	213
19.8.2. Normal Post Manufacture Certification.....	213

19.9. Outgassing Performance.....	214
19.9.1. Information Normally Required Prior to Manufacture.....	214
19.9.2. Normal Post Manufacture Certification.....	214
19.10. Baking.....	214
19.10.1. Information Normally Required Prior to Manufacture.....	214
19.10.2. Normal Post Manufacture Certification.....	215
ITER Vacuum Handbook Appendix 20.....	216
20. Standard components.....	216
ITER Vacuum Handbook Appendix 21.....	222
21. Glossary of vacuum terms.....	222
ITER Vacuum Handbook Appendix 22.....	228
22. Allowable strain in cryogenic piping and cryogen components.....	228
22.1. Background.....	228
22.1. Requirement.....	228
22.2. Solution annealing.....	228
22.3. Basis of the requirements.....	228
22.3.1. Austenitic steels.....	229
22.3.2. Higher alloying of the stainless steel.....	229
22.3.3. Cold work at room temperature.....	229
22.3.4. SS304L the Effect of Martensitic Transformation.....	230
22.3.5. SS316L the Effect of martensitic transformation.....	231
22.4. References.....	232
ITER Vacuum Handbook Attachment 1.....	233
At. 1. Inspection and Qualification of Welded Joints.....	233
1. Scope.....	233
2. The Welding and Inspection Plan.....	233
3. Welder and operator Qualification.....	233
4. Applicable Standards.....	233

5. Welding Procedure Specification.....	234
6. Welding Procedure Qualification Record.....	235
6.1. Qualification of the Welding Procedure Specification.....	236
6.2. Extent of Approval.....	236
6.2.1. Material Groups.....	236
6.2.2. Base Materials.....	236
6.2.3. Thickness Range.....	237
6.2.3.1. Thickness Range for Welds Excluding Fillet and Branch.....	237
6.2.3.2. Thickness Range for Fillet Welds.....	238
6.2.3.3. Thickness Range for Branch Pipes (Diameter Range).....	239
6.2.4. Range of Approval of Welded Joints.....	239
6.2.5. Range of Approval Welding Consumables.....	239
6.2.6. Welding Processes.....	239
6.2.7. Welding Position.....	239
6.3. Non ...Destructive Examination.....	240
6.3.1. Examination.....	240
6.3.2. Acceptance Criteria.....	241
6.4. Destructive Tests.....	242
6.4.1. Test Specimens.....	242
6.4.2. Test Results.....	243
6.4.3. Qualification for Welds Under Stressed Applications.....	243
7. Production Welds.....	243
7.1. Inspection of Fusion Welded Joints.....	244
7.2. Production proof samples.....	244
7.3. Helium Leak Testing of Production Welds.....	246
7.4. Repair by welding of production welds.....	246
8. Documentation.....	246
ITER Vacuum Handbook Attachment 2.....	247

At. 2. Cleanliness Requirements for the Assembly of Vacuum Equipment.....	247
1. Terminology.....	247
2. Scope.....	247
3. Purpose.....	248
4. General Requirements.....	248
4.1. Management of Work.....	248
4.1.1. Risk Assessment.....	248
4.1.2. Work Instruction.....	248
4.1.2.1. Deviations from the WI.....	248
4.1.3. Personnel.....	248
4.2. Area Designation.....	249
4.3. Operator Attire.....	249
4.3.1. Personnel Protective Equipment.....	249
4.3.2. Ex-vessel work.....	249
4.3.3. In-vessel work.....	249
4.4. Tools.....	249
4.4.1. General.....	249
4.4.2. Tools for use in-vessel.....	249
4.4.2.1. Hand Tools.....	250
4.4.2.2. Power Tools.....	250
4.4.2.3. Welding/ Brazing Equipment.....	250
4.4.2.4. Tools Containing Fluids.....	250
4.4.2.5. Equipment, trolleys, jigs, slings, etc.....	251
4.4.2.6. Vacuum Pumps.....	251
4.4.2.7. Specialised Tools.....	251
4.5. Materials.....	251
4.5.1. Marking.....	251
4.5.2. Adhesive Tape and plastic coverings.....	251

4.5.3. Grinding and Cutting Wheels.....	252
4.5.4. Products for Ultrasonic Testing (UT).....	252
4.5.5. Products for Liquid Penetrant Examination.....	252
4.5.6. Machining Fluids.....	252
4.5.7. Unacceptable Materials.....	252
5. Performance of Work.....	252
5.1. In-Vessel Dressing Working Procedures.....	252
5.2. Cutting, Drilling, Grinding, Filing and Polishing.....	253
5.3. Welding, Brazing & Soldering.....	253
5.4. Mechanical Joining.....	254
5.5. Marking.....	254
6. Specific Requirements.....	254
6.1. Assembly and Integration.....	254
6.1.1. VQC 1 and 2 Demountable Joints.....	254
6.1.2. Ex-Vessel.....	254
6.1.2.1. VQC 1.....	255
6.1.2.2. VQC 2.....	255
6.1.2.3. VQC 3 and 4.....	255
6.2. In-vessel.....	255
6.2.1. General.....	255
6.2.2. VQC 1.....	256
6.2.3. Ventilation.....	256
6.2.3.1. VQC 1 & 2 ventilation air flow rate.....	256
6.2.3.2. VQC 1 and 2 ventilation air humidity.....	256
6.2.3.3. Particulate count.....	256
6.3. Work Areas in the Vicinity of VQC 1 and 2 Systems.....	256
7. References.....	256

ITER Vacuum Handbook Appendix 1

Guideline (not under Configuration Control)

1. Base Pressures and Expected Vacuum System Pumping Speed

1.1. Scope

This appendix relates gives base pressures that it is expected systems with a Vacuum Classification will operate. The appendix also gives the expected pumping speeds of ITER vacuum systems. This appendix is intended as a guide and figures will be updated as the system design matures.

1.2. Base Pressures

Base pressures pertaining to VQC are given in Table 2-1.

	VQC1 ¹	VQC2 ²	VQC3 ³	VQC4 ³
Base Pressure (Pa)	10 ⁻⁷ - 10 ⁻⁴	<10 ⁻⁴	10 ⁻⁶ -10 ²	10 ⁻⁴

¹ Before operations, the base pressure in the ITER vacuum vessel will be required to be 10⁻⁵ Pa or less for hydrogen isotopes and 10⁻⁷ Pa or less for any other individual species at 100°C after bake-out and conditioning.

²Pressures at ambient (with magnets cold). Lower values expected if total pressure is not helium dominated.

³Total pressure when pump down, some system may operate at higher pressures.

Table 2-1 Base pressure pertaining to VQC.

1.3. Pumping speeds for Cryopumps

The expected pumping speeds various large ITER cryopumps are given in Table3-1. Pumping speeds are given at the pump inlet with inlet valves fully open.

Cryopumping System	VQC	Pumping Speed ($\text{m}^3\cdot\text{s}^{-1}$)				
		H ₂	D ₂	DT	He	N ₂
Torus Vacuum Cryopump¹	1A	78	55	49	52	21
Cryostat Vacuum Cryopump²	2A	>78	>55	>49	>52	>21
Heating Neutral Beam Cryopump	1A	4700	3600	3255	TBD ³	1380
Diagnostic Neutral Beam Cryopump	1A	2900	2270	2035	TBD ³	860

¹ The torus cryopumping system consists of 6 cryosorption pumps for which the individual pumping speed is given. The total pumping speed is dependent on the operating cycle of the pumps. The conductance of the divertor duct restricts the total pumping speed available. Modelling of the 2001 divertor duct configuration gave a maximum molecular flow pumping speed for Deuterium of 20 m^3/s when using 4 ducts for the pumping. The current more open divertor duct configuration is estimated to give a molecular flow pumping speed for Deuterium of 100 m^3/s when using 4 ducts and 4 pumps for the pumping.

² One cryopump only, not including the cold surfaces of the magnets or the thermal shield. Pumping speed of the torus cryopump is used, but the gas conductance to the pump housing will be higher than for the torus pump. Two pumps are available to pump, but at times one will have to be offline for regeneration.

³ Pending Monte Carlo simulations.

Table 3-1 Expected pumping speeds of large cryopumps.

1.4. Pumping speeds for roughing pumps

The design of the roughing system and the roughing lines is at an early stage and hence pumping speed cannot yet be accurately provided. The figures below outline the required provisional roughing pump(s) performance.

- Torus ~1330 m³, 10⁵ Pa to 10 Pa in 24 Hours.
- 1 torus cryopump, ~18 m³, max 30 KPam³† (Hydrogen isotopes), to 10 Pa in 150 sec.
- Cryostat ~8500 m³, 10⁵ Pa to 10 Pa in 24 Hours.
- 1 cryostat cryopump, ~18 m³, max 30 KPam³ (Helium + Hydrogen), to 10 Pa in 150 sec.
- NIBs ~ 171 m³ + 171 m³ + 170 m³ + 93 m³, 10⁵ Pa to 10 Pa in 24 Hours.
- 1 NIB cryo-pump, ~170 m³, max 300 KPam³ (Hydrogen isotopes), to 20 Pa in 650 sec.
- PI – overnight gas transfer to TEP.
- Adequate pumping for Auxiliaries.

†May double.

ITER Vacuum Handbook Appendix 2

Baseline Report (not under Configuration Control)

2. Environmental Cleanliness requirements for Vacuum Quality Classification

2.1. Scope

This Appendix provides guidelines relating to the cleanliness requirements for the post cleaning handling of vacuum components for installation in the various ITER Vacuum systems. It only refers to the post final cleaning cleanliness requirements to maintain the achieved cleanliness.

It is anticipated that further guidance which will not be mandatory may be provided in the future.

2.2. Post Cleaning Handling of Vacuum Components

The following details are reproduced from the ITER Vacuum Handbook (Issue 2.3), Section 24.5 and Table 24.1 and are therefore mandatory.

“After final cleaning, the handling of vacuum equipment shall be controlled to preserve cleanliness. General area cleanliness requirements pertaining to Vacuum Classification are summarized in Table 2-1. The suitability of any given area used for handling vacuum equipment should be assessed on a regular basis by monitoring the airborne particulate count and should not exceed 5.0×10^6 particles of size $> 0.5 \mu\text{m}$ per m^3 for VQC 1.

VQC	Cleanliness requirements	Personnel	Area Cleanliness	Monitoring
1	Segregated clean area. Limited Access to authorized personnel. Authorized equipment operated to approved procedures. Management of equipment (e.g. no vacuum pumps exhausting into clean area)	Trained personnel. Protective hair nets. Powder free latex or nitrile outer gloves. Clean white overalls. Overshoes. Clean job specific footwear	Daily Cleaning of area including floors and surfaces. Sticky mats at area entry	Daily air quality checks. Results stored in component document package. Weekly cleanliness test of area with results stored in component document package
2	Authorised equipment operated to approved procedures. Management of equipment (e.g. no vacuum pumps exhausting into clean area)	Trained personnel Powder free latex or nitrile outer gloves for the handling of clean equipment	Daily Cleaning of work area including floors and surfaces.	
3&4	House Keeping	Trained personnel. Powder free latex or nitrile outer gloves for the handling of clean equipment	Daily cleaning of area.	

Table 2-1 Environmental cleanliness pertaining to VQC.

Additional cleanliness requirements shall be defined in the component installation procedures.”

ITER Vacuum Handbook Appendix 3

Guideline (not under Configuration Control)

3. ITER Approved Materials

3.1. Scope

This appendix relates to the materials *accepted* for use in ITER vacuum exposed to the ITER vacuum environments.

The ITER Vacuum Handbook (section 5.1) states that “Only materials *accepted* by ITER for the relevant Vacuum Classification shall be used on ITER vacuum systems. All material for use in vacuum shall be clearly specified at the design stage and certified in accordance with EN 10204 2.2, 3.1 or 3.2, or equivalent, before being used in manufacturing.”

Pursuant to this, materials which may be used freely on vacuum systems with the Vacuum Classifications stated are listed in the tables below.

Materials listed in this Appendix and shown as being subject to restricted use for a particular Vacuum Classification are subject to either an overall quota or to particular restrictions on their position of use. *Acceptance* for any particular vacuum application of such a material shall be obtained by submitting the Material Approval Request Form, stored on IDM (ITER_D_2MGWR4), to the ITER Vacuum RO. An example of this form completed is to be found at the end of this Appendix.

3.2. Materials not on the Approved List

Materials which are not on the *accepted* list may be proposed for use in vacuum. If the vacuum properties of the material are not sufficiently well documented for an assessment to be carried out, a programme of measurement of the relevant properties shall be agreed between the proposer and the designated ITER Vacuum RO.

Details of materials to be considered for *acceptance* shall be submitted to the ITER Vacuum RO using the Material Approval Request Form. The proposer shall agree in advance with the ITER Vacuum RO a plan detailing the type and method of testing to qualify the material for use. The Materials Approval Request Form along with the test data, report and supporting documentation, including any *supplier's* data (Certificates of Conformity, etc.), shall be submitted for consideration.

Materials qualified in this way may be added to the *accepted* list.

3.3. Material Selection / Qualification

The materials listed in the following tables have been considered in terms of usage (vapour pressure, outgassing etc.) and in terms of the environment of intended use. The properties of materials may change either permanently or temporarily when irradiated.

Such changes which can affect their suitability for use in vacuum may include:

- Induced radioactivity – which might necessitate the use of remote handling techniques

to disassemble or remove a component (e.g. steels may become active). Induced activity may be long-lived or short-lived.

- Mechanical degradation – which might affect the physical integrity of a component or a bond between components or which may generate particulates which could spread through a vacuum system (e.g. PTFE degenerates to a powder). Such changes are permanent.
- Transmutation – where a particular atomic species with good vacuum properties is transformed into one with poor vacuum properties (e.g. silver transmutes to cadmium). The products formed by transmutation can themselves transmute hence such changes can not be considered permanent.
- Chemical change – where the material decomposes under the influence of radiation (e.g. Viton releases hydrochloric acid, and PTFE releases fluorine, both of which are undesirable). Such changes are permanent.
- Desorption – under the influence of radiation, many materials exhibit enhanced outgassing due to induced desorption (e.g. hydrogen from steel when irradiated with X-rays). This stops when the source of radiation is switched off.

The effect of irradiation has been considered for *accepted* materials, and shall be considered in the qualification when materials not on the list are assessed for inclusion on the list.

Table 3-1 Accepted materials

Material / Material Class	Grades, (or composition applicable to ITER)	Vacuum Quality Classification							
		1A	1B	2A	2B	3A	3B	4A	4B
Austenitic stainless steels	316L, 316LN 316L(N)-IG + Corresponding EN grades	✓	✓	✓	✓	✓	✓	✓	✓
	316 + Corresponding EN grades	✗	✓	†	✓	†	✓	†	✓
	316Ti SA-240 (NB Bellows Convolutions) MAR: ITER_D_TT37NF			✓					

KEY: ✓ = approved for use. ✗ = not approved for use. † = restricted use

Material / Material Class	Grades, (or composition applicable to ITER)	Vacuum Quality Classification							
		1A	1B	2A	2B	3A	3B	4A	4B
	316Ti (Electical and optical patch boxes) MAR: ITER_D_TLM3YP				✓				
	304L 304LN 304B4 + Corresponding EN grades	✓	✓	✓	✓	✓	✓	✓	✓
	304 304 B7 Outgassing data:- ITER_D_EMZ98G + Corresponding EN grades	✗	✓	†	✓	†	✓	†	✓
	Austenitic stainless steels	YDH 50 MAR:- ITER_D_4CRYM8	✓	✓	✓	✓	✓	✓	✓

KEY: ✓ = approved for use. ✗ = not approved for use. † = restricted use

Material / Material Class	Grades, (or composition applicable to ITER)	Vacuum Quality Classification							
		1A	1B	2A	2B	3A	3B	4A	4B
Austenitic Chromium-Manganese-Nickel stainless steels	XM-19 (UNS S20910), MAR:- ITER_D_DG7SKX JJ1	✓	✓	✓	✓	✓	✓	✓	✓
Austenitic Chromium-Manganese-Nickel stainless steels	Nitronic-60 (UNS S21800) MAR:- ITER_D_CA3TB6 Material data sheet ITER_D_CX9QCX Material information ITER_D_DCEREP	✓	✓	✓	✓	✓	✓	✓	✓
Precipitation Hardening Iron Base Super-alloy	Grade 660 (UNS S66286), another name A286 + Corresponding EN grades	✓	✓	✓	✓	✓	✓	✓	✓
Ferritic (martensitic) stainless steel	430 (UNS S43000) Eurofer, F82H, Rusfer,	✓	✓	✓	✓	✓	✓	✓	✓

KEY: ✓ = approved for use. ✗ = not approved for use. † = restricted use

Material / Material Class	Grades, (or composition applicable to ITER)	Vacuum Quality Classification							
		1A	1B	2A	2B	3A	3B	4A	4B
Ferritic (martensitic) stainless steel	431 (UNS S43100) (1.4057) ITER roughing pump shaft MAR:- ITER_D_DCCQYE Materials cert ITER_D_DBY4WW	x	x	x	x	†	†	x	x
Ferritic (martensitic) stainless steel	431 (UNS S43100) (1.4059) ITER roughing pump rotor and case MAR:- ITER_D_DCHJDM Materials cert ITER_D_DCEQ7B	x	x	x	x	†	†	x	x
Kovar	ASTM F15 KV-1~9	✓	✓	✓	✓	✓	✓	✓	✓
Nickel		✓	✓	✓	✓	✓	✓	✓	✓
Nickel based Alloys	Nimonic 80A(UNS N070080)	✓	✓	✓	✓	✓	✓	✓	✓

KEY: ✓ = approved for use. x = not approved for use. † = restricted use

Material / Material Class	Grades, (or composition applicable to ITER)	Vacuum Quality Classification							
		1A	1B	2A	2B	3A	3B	4A	4B
	Monel 400	✓	✓	✓	✓	✓	✓	✓	✓
	Alumel (95% Ni, 2% Mn, 2%Al, 1%Si)	✗	†	✗	✓	✗	✓	✗	✓
	Chromel (90%-10% Ni – Cr)	✓	✓	✓	✓	✓	✓	✓	✓
	Alloy 718 (UNS N07718) Alloy 625 (UNS N06625)	✓	✓	✓	✓	✓	✓	✓	✓
	Inconel 708 Bellows seal MAR:- ITER_D_KTP2JW	✓	✓	✓	✓	✓	✓	✓	✓
	N-type thermocouple MAR :- ITER_D_64J7S9	✗	✗	✗	✓	✗	✗	✗	✗
	Nilo 42 (Nickel Iron Alloy 42 material) MAR:- ITER_D_QTVQ7F	✗	✓	✗	✓	✗	✓	✗	✗

KEY: ✓ = approved for use. ✗ = not approved for use. † = restricted use

Material / Material Class	Grades, (or composition applicable to ITER)	Vacuum Quality Classification							
		1A	1B	2A	2B	3A	3B	4A	4B
	Inconel X-750 (UNS N07750, DIN W.-Nr. 2.4669) MAR: ITER_D_S98EXM Material datasheet ITER_D_SM54DQ	✓	✓	✓	✓	✓	✓	✓	✓
Nickel based Braze	STEMET 1301 amorphous brazing alloy Vacuum brazing of W-Cu joint in the Divertor Dome PFUs armour (only PRPs) MAR:- ITER_D_7NTH2J Outgassing data:- ITER_D_7NSWW8 Mat Cert ITER_D_7NTH2J	✗	✓	✗	✓	✗	✓	✗	✓
	Microbraz 10 Alloy BNi6 (Ni / P 11%) Brazing of stainless steel cable sheaths into stainless steel bulkheads. MAR:- ITER_D_QZW8DY	✓	✓	✓	✓	✓	✗	✗	✗

KEY: ✓ = approved for use. ✗ = not approved for use. † = restricted use

Material / Material Class	Grades, (or composition applicable to ITER)	Vacuum Quality Classification							
		1A	1B	2A	2B	3A	3B	4A	4B
	Ni 102 Nickel-based high temp brazing paste For Brazing of non-vacuum boundary components DNB Beam (AKA:-Ni 102, BNi2 , L-Ni2, B-Ni82CrSiBFE-970/1000, 4777F, 9500/97) MAR ITER_D_S43LCB	x	✓	x	✓	x	✓	x	✓
Nickel based Braze	Nickel - Phosphorus 11% vacuum braze for the 6x diamagnetic coils (55.AG) under Triangular Support MAR ITER_D_S5EHB2	x	✓	x	✓	x	✓	x	✓

KEY: ✓ = approved for use. x = not approved for use. † = restricted use

Material / Material Class	Grades, (or composition applicable to ITER)	Vacuum Quality Classification							
		1A	1B	2A	2B	3A	3B	4A	4B
Pure Copper	Oxygen Free (OF) UNS C10200 Oxygen Free electronic (OFE) UNS C10100 EU grades: Cu-ETP (CW004A), Cu-FRTP, (CW006A), Cu- OF (CW008A), Cu-OFE (CW009A), Cu-PHCE (CW022A)	†	✓	✓	✓	✓	✓	✓	✓
Pure Copper	Oxygen Free (OF) UNS C10200 OF (CW008A) MAR:- ITER_D_NT9JT5	†	✓	✓	✓	✓	✓	✓	✓

KEY: ✓ = approved for use. ✗ = not approved for use. † = restricted use

Material / Material Class	Grades, (or composition applicable to ITER)	Vacuum Quality Classification								
		1A	1B	2A	2B	3A	3B	4A	4B	
Copper alloys	CuCrZr-IG: Cr (0.6 – 0.9 %), Zr (0.07 – 0.15 %) CuCr1Zr (CW 106C) CuCrZr (UNS C18150) БрХІІр (RF grade) YZC (JA grade)	✓	✓	✓	✓	✓	✓	✓	✓	✓
	CuBe1.7 MAR:- ITER_D_RBENAP	✗	✓	✗	✗	✗	✗	✗	✗	✗
	CuBe2 MAR:- ITER_D_RB34RC	✗	✓	✗	✗	✗	✗	✗	✗	✗
	SeCu MAR:- ITER_D_R7NEZM	✗	✓	✗	✗	✗	✗	✗	✗	✗

KEY: ✓ = approved for use. ✗ = not approved for use. † = restricted use

Material / Material Class	Grades, (or composition applicable to ITER)	Vacuum Quality Classification							
		1A	1B	2A	2B	3A	3B	4A	4B
Copper alloys- Bronze	Aluminum bronze: UNS C63200,(82Cu-9Al-5Ni4Fe), CuAl10Ni5Fe4 (CW307G) CW301G (CuAl6Si2Fe)	†	✓	✓	✓	✓	✓	✓	✓
Copper alloys- Bronze	Aluminium Bronze Casting (SO-5) (oilless bearing for in -vessel mirror motors. MAR:- ITER_D_4CT93S	✗	✓	✗	†	✗	†	✗	†
Copper alloys- Bronze	Bronze (Cu-Sn-Pb) Application is VQC N/A (approved for installation use only) MAR: ITER_D_UG2K5V								
Copper alloys- Alumina Dispersion Strengthened	Glidcop Al60 Glidcop Al25-IG Al-15	✓	✓	✓	✓	✓	✓	✓	✓

KEY: ✓ = approved for use. ✗ = not approved for use. † = restricted use

Material / Material Class	Grades, (or composition applicable to ITER)	Vacuum Quality Classification							
		1A	1B	2A	2B	3A	3B	4A	4B
Copper alloys- Alumina Dispersion Strengthened	Al-15 (Mirrors for EC Equatorial launcher) MAR:-ITER_D_4CQPLA	✗	✓	✗	✓	✗	✓	✗	✓
Copper-based braze	Nicumán 23 brazing alloy as a brazing alloy for use in the divertor MAR:- ITER_D_9K83MF Outgassing data:- ITER_D_6XLFJQ	✗	✓	✗	✗	✗	✗	✗	✗
Copper-based braze	Nicumán 37 brazing alloy for use in VQC 1B as a brazing alloy for use in the divertor. MAR :- ITER_D_9K6V2C Outgassing data:- ITER_D_6XLFJQ Materials cert ITER_D_9K6V2C	✗	✓	✗	✗	✗	✗	✗	✗

KEY: ✓ = approved for use. ✗ = not approved for use. † = restricted use

Material / Material Class	Grades, (or composition applicable to ITER)	Vacuum Quality Classification							
		1A	1B	2A	2B	3A	3B	4A	4B
Copper-based braze	STEMET 1101 microcrystalline brazing alloy Vacuum brazing of Cu-CuCrZr joint in the Dome PFUs armour MAR:- ITER_D_7NXAUN Outgassing data:- ITER_D_7NSWW8 Materials certificate ITER_D_7NSWW8	x	✓	x	✓	x	✓	x	✓

KEY: ✓ = approved for use. x = not approved for use. † = restricted use

Material / Material Class	Grades, (or composition applicable to ITER)	Vacuum Quality Classification							
		1A	1B	2A	2B	3A	3B	4A	4B
Copper-based braze	STEMET 1108 microcrystalline brazing alloy Vacuum brazing of Cu-CuCrZr joint in the Dome PFUs armour MAR:- ITER_D_7NSWW8 Outgassing data:- ITER_D_7NSWW8 Materials certificate ITER_D_7NSWW8	x	✓	x	✓	x	✓	x	✓
Beryllium	S – 65C VHP, DShG-200, TGP-56FW, CN-G01	✓	✓	✓	✓	✓	✓	x	x
Aluminium	Pure or alloys	†	✓	✓	✓	✓	✓	✓	✓
	Aluminium alloy EN AW-6082-T6 MAR : ITER_D_S97FXR Deviation request also required for this VQC 1A application	†							

KEY: ✓ = approved for use. x = not approved for use. † = restricted use

Material / Material Class	Grades, (or composition applicable to ITER)	Vacuum Quality Classification							
		1A	1B	2A	2B	3A	3B	4A	4B
Tungsten	Pure sintered W and rolled, cast W alloy, W-1%La ₂ O ₃ CVD	✗	✓	✗	✓	✗	✓	✗	✓
Tungsten Carbide	WC Cemented Carbide (Bearing Ring). MAR:-ITER_D_4CSC86 Mechanical pump (sliding seal) MAR :- ITER_D_L25NLL	✗	✓	✗	✓	✗	✓	✗	✓
Caesium		✗	✓	✗	✓	✗	✓	✗	✓
Gold		†	†	†	✓	✓	✓	✓	✓
Gold	Thin leaf 100 micron (bonding agent) MAR:- ITER_D_QDASPX	✗	†	✗	✗	✗	✗	✗	✗

KEY: ✓ = approved for use. ✗ = not approved for use. † = restricted use

Material / Material Class	Grades, (or composition applicable to ITER)	Vacuum Quality Classification							
		1A	1B	2A	2B	3A	3B	4A	4B
Gold based braze	Nioro brazing materials (AuNi 82/18%) MAR: ITER_D_TVU72E	✓	✓	✓	✓	✓	✓	✓	✓
Silver		†	†	†	✓	✓	✓	✓	✓
Silver-based braze	BAG-8 (Japanese Industrial Standard; JIS Z3261) Ag as filler material for brazing on the DNB bushing MAR :- ITER_D_AJL8YX Deviation request ITER_D_4AHGK6 Transmutation data ITER_D_4FJRHJ, ITER_D_7PGX7C	✗	†	✗	✗	✗	✗	✗	✗
Silver-based braze	BrazeTec_CB10 MAR: ITER_D_UMF87D		†						

KEY: ✓ = approved for use. ✗ = not approved for use. † = restricted use

Material / Material Class	Grades, (or composition applicable to ITER)	Vacuum Quality Classification							
		1A	1B	2A	2B	3A	3B	4A	4B
Silver-based braze	BPd-2 MAR: ITER_D_UXN7AY				†				
Tantalum	Sheet MAR:-ITER_D_2LN64R	✓	✓	✓	✓	✓	✓	✓	✓
Germanium		†	✓	†	✓	†	✓	†	✓
Samarium Cobalt (Sm ₂ Co ¹⁷)	R26HS	✗	✓	✗	✓	✗	✓	✗	✓
Zinc		✗	✗	✗	✗	✗	✗	✗	✗
Cadmium		✗	✗	✗	✗	✗	✗	✗	✗
Titanium	Pure or alloys	†	†	†	✓	†	✓	†	✓

KEY: ✓ = approved for use. ✗ = not approved for use. † = restricted use

Material / Material Class	Grades, (or composition applicable to ITER)	Vacuum Quality Classification							
		1A	1B	2A	2B	3A	3B	4A	4B
Titanium	Titanium ASTM Grade2 T2 & 5 T5 ICH & CD antenna: Removable vacuum transmission lines MAR:- ITER_D_6R2ZJW Related attachments ITER_D_6R2ZJW, ITER_D_6R2ZJW, ITER_D_6R2ZJW	†	×	×	×	†	×	×	×
Titanium based braze	Ticuni Braze MAR: ITER_D_UMFFFP		†						
Quartz		✓	✓	✓	✓	✓	✓	✓	✓
Silicon	Mono-crystalline, 380 µm thick board Ex-vessel magnetic sensor (55.A5/A6 MEMS) Total mass ~2.5g for all sensors MAR:- ITER_D_DFVQ4C	×	×	×	†	×	×	×	×

KEY: ✓ = approved for use. × = not approved for use. † = restricted use

Material / Material Class	Grades, (or composition applicable to ITER)	Vacuum Quality Classification							
		1A	1B	2A	2B	3A	3B	4A	4B
Silicon	Poly-crystalline 40 µm diameter plugs through 380 µm thick mono-Si circuit board Ex-vessel magnetic sensor (55.A5/A6 MEMS) Total mass ~0.001g (1mg) for all sensors MAR ITER_D_DG5JJR	x	x	x	†	x	x	x	x
Silica,	Fused SiO ₂	✓	✓	✓	✓	✓	✓	✓	✓
Composite (diamond, silicon carbide, silicon)	Skeleton-1 MAR:- ITER_D_64NG84	x	✓	x	x	x	x	x	x
Diamond	Pure and DLC, CVD	✓	✓	✓	✓	✓	✓	✓	✓
Graphite	Pyrolytic (Langmuir Probe) MAR:- ITER_D_2LUWMJ	x	†	x	†	x	x	x	x

KEY: ✓ = approved for use. x = not approved for use. † = restricted use

Material / Material Class	Grades, (or composition applicable to ITER)	Vacuum Quality Classification							
		1A	1B	2A	2B	3A	3B	4A	4B
(see note 1)	GR-1 (restricted to allow tracking). MAR:- ITER_D_4CRPVS	x	†	x	†	x	x	x	x
	Papyex: N 998 Flexible Graphite MAR: ITER_D_KZWER7 Technical guide ITER_D_RZM4SU	x	†	x	x	x	x	x	x
Composite (Carbon Fibre Composite CFC, see note 1)	SNECMA and Dunlop: various grades Supercarb NB 31 (3D), NIC-01 Toyo Tanso: CX2002U (2D)	x	✓	x	✓	x	✓	x	✓
Porcelain	C221	✓	✓	✓	✓	✓	✓	✓	✓
Ceramic	Kyocera A479	✓	✓	✓	✓	✓	✓	✓	✓

KEY: ✓ = approved for use. x = not approved for use. † = restricted use

Material / Material Class	Grades, (or composition applicable to ITER)	Vacuum Quality Classification							
		1A	1B	2A	2B	3A	3B	4A	4B
Glass Ceramic	DuPont 951 Green Tape For Low-Temperature Co-fired Ceramics sensor applied to PBS 55.AA/AB/AC MAR ITER_D_S22ME4 Outgassing test reports ITER_D_QYRA8N ITER_D_QYM8ZD	x	✓	x	✓	x	✓	x	✓
	MACOR (MGC) Small machined parts MAR:-ITER_D_LF5RDE Vac data:- ITER_D_LEYH7S	x	✓	x	✓	x	✓	x	✓
	Shapal Hi-M SOFT (machinable AlN) In-vessel Magnetic Sensors (55.AA/AB/AC/AJ) applications Outgassing data ITER_D_C9TP4H Material datasheet ITER_D_C9XYVT	x	✓	x	✓	x	✓	x	✓

KEY: ✓ = approved for use. x = not approved for use. † = restricted use

Material / Material Class	Grades, (or composition applicable to ITER)	Vacuum Quality Classification							
		1A	1B	2A	2B	3A	3B	4A	4B
MgAl ₂ O ₄		✓	✓	✓	✓	✓	✓	✓	✓
MgO	Magnesium oxide as base insulation material for the In-Vessel Coils conductor. Powder glued and sintered in blocks, confined in the conductor jacket MAR ITER_D_STESWL	✗	✓	✗	✓	✗	✓	✗	✓
Titanium dioxide TiO ₂		✗	✓	✗	✓	✗	✓	✗	✓
Alumina Al ₂ O ₃	Grade IV to ASTM D2442	✓	✓	✓	✓	✓	✓	✓	✓

KEY: ✓ = approved for use. ✗ = not approved for use. † = restricted use

Material / Material Class	Grades, (or composition applicable to ITER)	Vacuum Quality Classification							
		1A	1B	2A	2B	3A	3B	4A	4B
Alumina (Al ₂ O ₃)	Aluminum Oxide (TS-03312) Surface coating for slid pin, internal shield etc MAR:- ITER_D_4CQG7F	x	✓	x	x	x	x	x	x
Alumina cyanate ester	Alumina Filled Cyanate Ester (MC7885-UF) Ex-vessel Magnetic Sensors (55.A5/A6 MEMS), Qty ~30g for all sensors MAR:- ITER_D_DFZ4YK	x	x	x	✓	x	x	x	x
Aluminium Nitride	Shapal SH-15 (Small moulded/machined parts) MAR:- ITER_D_EH72BL	x	†	x	†	x	x	x	x

KEY: ✓ = approved for use. x = not approved for use. † = restricted use

Material / Material Class	Grades, (or composition applicable to ITER)	Vacuum Quality Classification							
		1A	1B	2A	2B	3A	3B	4A	4B
Aluminium Nitride	Shapal M-soft (sintered composite of Al nitrate and B nitrate) MAR:- ITER_D_C9TCXH Outgassing data:- ITER_D_C9TP4H	x	†	x	†	x	x	x	x
Aluminium Nitride	Aluminium Nitride (Circuit Board Substrate) Ex-vessel sensor, total quantity 1.3kg maximum MAR:- ITER_D_DG7QJY Outgassing Data :- ITER_D_DG46FA	x	x	x	†	x	x	x	x
Aluminium Nitride	AlN (high purity sintered for IVS RF shield) MAR ITER_D_SMX5GR Outgassing data ITER_D_DG46FA Chemical analysis ITER_D_SLZRLQ	x	✓	x	✓	x	✓	x	✓

KEY: ✓ = approved for use. x = not approved for use. † = restricted use

Material / Material Class	Grades, (or composition applicable to ITER)	Vacuum Quality Classification							
		1A	1B	2A	2B	3A	3B	4A	4B
Silicon Nitride (SiN ₄)	TSN-03 (in vacuum ball bearing) MAR:- ITER_D_4C5QZJ	x	✓	x	x	x	x	x	x
Caesium Iodide CsI	Ti activated	x	✓	x	✓	x	✓	x	✓
Resin -Epoxy	TGDDM	x	x	†	✓	†	✓	x	✓
Resin -Epoxy	Araldite rapid MAR: ITER_D_UELUT4								✓
Resin -Cyanate Ester	Quartz Filled Cyanate Ester (MC7883-UF or MC9883-LPM) Bonding agent in sensor silicon wafer Ex-vessel Magnetic Sensors (55.A5/A6 MEMS), Qty ~30g for all sensors MAR:- ITER_D_DG4HDK	x	x	x	†	x	x	x	x

KEY: ✓ = approved for use. x = not approved for use. † = restricted use

Material / Material Class	Grades, (or composition applicable to ITER)	Vacuum Quality Classification							
		1A	1B	2A	2B	3A	3B	4A	4B
Optical glue	SKTN-MED optical glue MAR: ITER_D_76JZCP		†						
Composite (Epoxy / (glass fibre)	G10. Electrical insulator MAR:- ITER_D_4E9Q2M	x	x	x	✓	x	x	x	✓
	G11 / EPGC203. Electrical insulator MAR ITER_D_SRSQTV	x	x	x	x	x	x	x	✓
Inorganic adhesive	Thermoguss 2000	x	✓	†	✓	†	✓	x	✓
	Thermoguss 2000 MAR:- ITER_D_R69NWA Performance as a seal on MI cable must be demonstrated by qualification tests on actual cables	x	x	x	x	✓	x	x	x
Glass	S 2, R- and T	x	†	x	✓	x	✓	x	✓

KEY: ✓ = approved for use. x = not approved for use. † = restricted use

Material / Material Class	Grades, (or composition applicable to ITER)	Vacuum Quality Classification							
		1A	1B	2A	2B	3A	3B	4A	4B
Polyimide	Vespel	x	✓	x	✓	x	✓	x	✓
Polyimide	ERTALON 66 Application is VQC N/A (approved for installation use only) MAR: ITER_D_UG2BMP								
Polyimide	Thermoplastic Polyimide (TPI), Axon Cable MAR: ITER_D_RTNM3U This sample accepted by outgassing test in MAR				†				
PEEK (Polyether ether ketone)	As shrink tubing for steady-state sensors 55.A5/A6 MAR ITER_D_RT2T5V Product datasheet ITER_D_RMLNSM	x	x	x	✓	x	✓	x	✓

KEY: ✓ = approved for use. x = not approved for use. † = restricted use

Material / Material Class	Grades, (or composition applicable to ITER)	Vacuum Quality Classification							
		1A	1B	2A	2B	3A	3B	4A	4B
EPDM (Ethylene-propylene)	Use restricted to 2 nd , outer, seal gasket only (i.e. between SVS pumped volume/Air) in VQC 2A double sealed flanges (1 st , inner seal, being metallic)	x	x	†	x	x	x	x	x
Nitrile rubber (Buna – N)	Use restricted to 2 nd , outer, seal gasket only (i.e. between SVS pumped volume/Air) in VQC 2A double sealed flanges (1 st , inner seal, being metallic)	x	x	†	x	x	x	x	x
Superinsulation	Aluminium deposited Kapton, Mylar. Aluminium foil	x	x	x	†	x	x	x	✓
	Aluminium deposited Polyester	x	x	x	x	x	x	x	†
Halogenated materials	PTFE, Fibreslip (Teflon fibre-glass weave)‡ ‡ PTFE bearings are approved for positions where the predicted radiation fluence over the full operational life of ITER is less than 103 Gray (Gamma or Neutron dose equivalents)	x	x	x	✓	x	x	✓	✓

KEY: ✓ = approved for use. x = not approved for use. † = restricted use

Material / Material Class	Grades, (or composition applicable to ITER)	Vacuum Quality Classification							
		1A	1B	2A	2B	3A	3B	4A	4B
	Viton	x	x	†	†	†	✓	✓	✓
	Kalrez Non-vacuum application (3 rd party pump) VQC=N/A MAR:- ITER_D_L5MK2Q								
	Bromine (In Halogen lamp for CXRS Diagnostic in-situ calibration. MAR:- ITER_D_48D5EX	x	†	x	x	x	x	x	x
Barium Fluoride	Barium Fluoride vacuum windows MAR:- ITER_D_P8Q4NT ITER_D_32KTBX	✓	x	x	x	✓	x	x	x
Molybdenum	Molybdenum as solid pure form (i.e. not powdered or compound form)	✓	✓	✓	✓	✓	✓	✓	✓

KEY: ✓ = approved for use. x = not approved for use. † = restricted use

Material / Material Class	Grades, (or composition applicable to ITER)	Vacuum Quality Classification							
		1A	1B	2A	2B	3A	3B	4A	4B
Molybdenum	Tracks on surface of silicon wafer sensor Ex-vessel Magnetic Sensors Qty ~0.001g (1mg) total for all sensors MAR:- ITER_D_DG5ZG5	x	x	x	†	x	x	x	x
Molybdenum alloy	Mo alloy (Titanium(0.5)-Zirconium(0.08)- Molybdenum, TZM) MAR: ITER_D_TRZ5LS Outgassing data ITER_D_TR7YZC	✓	✓	✓	✓	✓	✓	✓	✓
MoS ₂	Molykote D-321 R Anti-Friction Coating MAR: ITER_D_U3HP3S								†
MoS ₂	Molykote D-321 R Anti-Friction Coating MAR: ITER_D_UAT6CB				†				

KEY: ✓ = approved for use. x = not approved for use. † = restricted use

Material / Material Class	Grades, (or composition applicable to ITER)	Vacuum Quality Classification							
		1A	1B	2A	2B	3A	3B	4A	4B
MoS ₂	Sputtered MoS ₂ MAR: ITER_D_TL5DS8		†						
MoS ₂		×	†	×		×	†	×	†
MoSe ₂		×	†	×	†	×	†	×	†
WS ₂		×	†	×	†	×	†	×	†
WSe ₂		×	†	×	†	×	†	×	†
Boron Nitride		×	✓	×	✓	×	✓	×	✓
Titanium Nitride (TiN)	PVD hard coating (anti-seizing of bolt threads, used generally) MAR:- ITER_D_2LPCE9	×	✓	×	✓	×	✓	×	✓

KEY: ✓ = approved for use. × = not approved for use. † = restricted use

Material / Material Class	Grades, (or composition applicable to ITER)	Vacuum Quality Classification							
		1A	1B	2A	2B	3A	3B	4A	4B
Boron Carbide		x	†	x	†	x	†	x	†
	Boron Carbide, Hot pressed sintered MAR: ITER_D_T7DB99		†						
Zirconium Nitride	Chemical Vapour Deposition Coating	x	†	x	†	x	†	x	†
Zirconia	ZrO ₂ with TiN coating Non-vacuum application (3 rd party pump) VQC=N/A MAR:- ITER_D_L239S5								

KEY: ✓ = approved for use. x = not approved for use. † = restricted use

Material / Material Class	Grades, (or composition applicable to ITER)	Vacuum Quality Classification							
		1A	1B	2A	2B	3A	3B	4A	4B
Zirconia	ZrO ₂ ceramic can in a mechanical vacuum pump Non-vacuum application (3 rd party pump) VQC=N/A MAR :- ITER_D_KZAGJN								
	ZrO ₂ sintered or plasma sprayed MAR:- ITER_D_R64Q62	x	✓	x	x	x	x	x	x
	Zirconia based adhesive RESBOND 940. MAR & Outgassing data ITER_D_RUDVER:				+				

KEY: ✓ = approved for use. x = not approved for use. † = restricted use

Material / Material Class	Grades, (or composition applicable to ITER)	Vacuum Quality Classification							
		1A	1B	2A	2B	3A	3B	4A	4B
Zirconia	ZrO ₂ ceramic can in a mechanical vacuum pump Non-vacuum application (3 rd party pump) VQC=N/A MAR :- ITER_D_KZAGJN								
	ZrO ₂ sintered or plasma sprayed MAR:- ITER_D_R64Q62	x	✓	x	x	x	x	x	x
	Zirconia based adhesive RESBOND 940. MAR & Outgassing data ITER_D_RUDVER:				†				

KEY: ✓ = approved for use. x = not approved for use. † = restricted use

3.4. Example Material Request Form

Material Approval Request _(v1.0)					Ref No: Mat-Cha-1 <i>(Assigned by Vacuum RO)</i>					
Material submitted for approval:		Ceramic TRADE Name xxx								
Proposed form:		Solid								
Proposed Use:		HV Bushing								
VQC of proposed use:		1A	1B	2A	2B	3A	3B	4A	4B	N/A
		<input checked="" type="checkbox"/>	<input checked="" type="checkbox"/>	<input checked="" type="checkbox"/>	<input checked="" type="checkbox"/>	<input checked="" type="checkbox"/>	<input checked="" type="checkbox"/>	<input checked="" type="checkbox"/>	<input checked="" type="checkbox"/>	<input type="checkbox"/>
If restricted give details of coverage (e.g. amount, surface area etc)										
Chemical Analysis / Material Safety Data Sheet available:		YES	Attached Copy document ref. (electronic if available)							
Agreed test plan:		NO	Attached Copy document ref. (electronic if available)							
Vacuum Test data Available:		YES	Attached Copy document ref. (electronic if available)							
Outgassing rate (at 100 °C)		N/A								
Vapour pressure (at 100 °C)		N/A								
Max temperature:	1000	Operating temperature:	240							
Pre installation treatment (baking, electropolishing etc)		Baked clean								
Requested by:	A.N.Other	Date Submitted:	25/03/09							
Affiliation :	USA	E-Mail	A.Other@USA.org							
Vacuum Material Approval Status: <i>(To be completed by ITER Vacuum Group RO)</i>										
Approved for VQC:		1A	1B	2A	2B	3A	3B	4A	4B	N/A
		<input checked="" type="checkbox"/>	<input checked="" type="checkbox"/>	<input checked="" type="checkbox"/>	<input checked="" type="checkbox"/>	<input checked="" type="checkbox"/>	<input checked="" type="checkbox"/>	<input checked="" type="checkbox"/>	<input checked="" type="checkbox"/>	<input type="checkbox"/>
Limits / Restrictions (Attached Doc.) [†]										
ITER Vacuum RO		Approver:		LPressure						
		Date:30/03/09								

Grey boxes to be completed by requesting officer. Boxes in Red to be completed by ITER Vacuum RO.

[†] Reasons for material rejections shall be supplied with the notification of material refusal.

Notes:-

1. Carbon and carbon composites shall be conditioned for (vacuum) use in accordance with the ITER Vacuum Handbook. ITER vacuum handbook ITER_D_29DFGH

ITER Vacuum Handbook Appendix 4

Guideline (not under Configuration Control)

4. ITER Accepted Fluids

4.1. Scope

This Appendix relates to fluids *accepted* to be used in the preparation and processing of materials and components which are exposed to the ITER vacuum environments, e.g. cutting fluids and cleaning solvents.

The ITER Vacuum Handbook (Section 6.1) states that:

1. “Cutting fluids for use on VQC 1 and 3 systems shall be water soluble, non- halogenated and phosphorus and sulphur free”.
2. “Accepted cutting fluids for use in VQC 1 and 3 vacuum applications are listed in Appendix 4. The use of other cutting fluids requires prior acceptance.
3. “Acceptance for the use of any particular non-approved cutting fluid shall be obtained by submitting the Fluid Acceptance Request Form, stored on IDM, to the ITER Vacuum Responsible Officer (RO).
4. “For VQC 2 & 4 vacuum applications it is recommended that cutting fluids be water soluble, non-halogenated and phosphorus and sulphur free¹. They should be chosen from those listed in Appendix 4. Where this recommendation is not followed particular care shall be taken to ensure the appropriateness of the cleaning procedures”.

The ITER Vacuum Handbook Section 24 states that:

“Lists of accepted cleaning fluids can be found in Appendix 4”.

Pursuant to this, materials which may be used freely for use on vacuum system items with the Vacuum Classifications stated are listed in the tables below.

4.2. Fluids not on the Accepted List

Fluids which are not on the *accepted* list may be proposed for use. If the vacuum related properties of the fluid are not sufficiently well documented for an assessment to be carried out, a programme of measurement of the relevant properties should be agreed between the proposer and the designated ITER Vacuum RO.

Details of fluids to be considered for *acceptance* should be submitted to the ITER Vacuum RO using the Fluid Acceptance Request Form. The proposer shall agree in advance with the ITER Vacuum RO a plan detailing the type and m Sulphur, phosphorus and halogen (fluoride & chloride) content below 200 ppm for each. method of testing to qualify the material for use. The Fluid *Acceptance* Request Form along with the test data, report and supporting documentation, including any *supplier’s* data (Certificates of Conformity, etc.), is to be submitted for

¹ Sulphur, phosphorus and halogen (fluoride & chloride) content below 200 ppm for each.

consideration.

Fluids qualified in this way may be added to the *accepted* list.

A completed sample of the Fluid *Acceptance* Form is to be found at the end of this Appendix.

4.3. Fluid Selection / Qualification

The fluids listed in the following tables have been considered in terms of usage for vacuum purposes.

The properties of interest for this purpose include, *inter alia*,

- Fitness for purpose, i.e. how well it does the job for which it is used
- Easy and complete removal from the vacuum surface
- No induced degradation of the vacuum properties of the surface, e.g. increased outgassing
- No significant physical change to the surface
- Health and safety considerations.

Fluids

Type	Name / type	Applicable to Vacuum Quality Classification							
		1A	1B	2A	2B	3A	3B	4A	4B
Cleaning fluids	Isopropyl Alcohol	✓	✓	✓	✓	✓	✓	✓	✓
	Ethyl Alcohol	✓	✓	✓	✓	✓	✓	✓	✓
	Acetone	✓	✓	✓	✓	✓	✓	✓	✓
	Axarel 9100™,	✓	✓	✓	✓	✓	✓	✓	✓
	Citrinox™	✓	✓	✓	✓	✓	✓	✓	✓
	P3 Almeco™, P36 or T5161	✓	✓	✓	✓	✓	✓	✓	✓
	RBS 25	✓	✓	✓	✓	✓	✓	✓	✓
	RBS 35								

KEY: ✓ = *accepted* for use. ✗ = *not accepted* for use. † = *accepted* for restricted use only

Type	Name / type	Applicable to Vacuum Quality Classification							
		1A	1B	2A	2B	3A	3B	4A	4B
	RBS A350	✓	✓	✓	✓	✓	✓	✓	✓
	Cleansafe 787 MAR: ITER_D_RWAQR3 Datasheet:- ITER_D_RWH2NT	✓	✓	✓	✓	✓	✓	✓	✓
	HC 500 Liquid cleaning agent (Used in electropolishing process for cryogenic piping for the pre-production cryopump) FAR ITER_D_RZ3F5Q SDS ITER_D_RZ7ZFP MDS ITER_D_RZJVUT Approved cleaning procedure ITER_D_S2FG8X	✓	✓	✓	✓	✓	✓	✓	✓
	NGL 17.40 P Precision Cleaning for Ultrasonic processes FAR ITER_D_SEW4QA	✓	✓	✓	✓	✓	✓	✓	✓

KEY: ✓ = *accepted* for use. ✗ = not *accepted* for use. † = *accepted* for restricted use only

Type	Name / type	Applicable to Vacuum Quality Classification							
		1A	1B	2A	2B	3A	3B	4A	4B
	DOWCLENE* 1601 Cleaning Fluid FAR ITER_D_STQSEK	✓	✓	✓	✓	✓	✓	✓	✓
	Oil Eater Manufacture of ITER-style vacuum flanges. FAR ITER_D_Q8DUKT SDS ITER_D_SRFUYV Cleaning Aqueous wash with Rebound 7 followed by DI water rinse	✓	✓	✓	✓	✓	✓	✓	✓
	CitriSurf 2310 MAR : ITER_D_UHXTT3	✓	✓	✓	✓	✓	✓	✓	✓
	RBS826 Cleaning fluid MAR : ITER_D_TF3G4P							✓	✓

KEY: ✓ = *accepted* for use. ✗ = *not accepted* for use. † = *accepted* for restricted use only

Type	Name / type	Applicable to Vacuum Quality Classification							
		1A	1B	2A	2B	3A	3B	4A	4B
	Rebound 7 Manufacture of ITER-style vacuum flanges. Aqueous wash followed by DI water rinse FAR ITER_D_QCK53E SDS ITER_D_SRF2G7	✓	✓	✓	✓	✓	✓	✓	✓
	Surtec®089 with Surtec®132 FAR:- ITER_D_TTWQVK	✓	✓	✓	✓	✓	✓	✓	✓
	PROCIV CUP FAR ITER_D_STHJGP	✓	✓	✓	✓	✓	✓	✓	✓
Cutting fluids	Castrol CareCut S 125	✓	✓	✓	✓	✓	✓	✓	✓
	Vasco 1045	✓	✓	✓	✓	✓	✓	✓	✓

KEY: ✓ = *accepted* for use. ✗ = *not accepted* for use. † = *accepted* for restricted use only

Type	Name / type	Applicable to Vacuum Quality Classification							
		1A	1B	2A	2B	3A	3B	4A	4B
	Vasco 7000 MAR ITER_D_RFQND9 MDS ITER_D_RAW9TK Chemical Analysis ITER_D_RZBSEF SDS ITER_D_RF4MWR	✓	✓	✓	✓	✓	✓	✓	✓
	Alusol M-FX Only approved for use for the processing of base material which is subject to subsequent machining / cleaning operations utilizing accepted water miscible fluids.	†	†	†	†	†	†	†	†
	Hocut 2000	✓	✓	✓	✓	✓	✓	✓	✓
	Hocut 795 HX Soluble Metalworking Oil FAR:- ITER_D_4H3QL6 Use accepted cleaning procedure	✓	✓	✓	✓	✓	✓	✓	✓

KEY: ✓ = *accepted* for use. ✗ = *not accepted* for use. † = *accepted* for restricted use only

Type	Name / type	Applicable to Vacuum Quality Classification							
		1A	1B	2A	2B	3A	3B	4A	4B
	Fluid Blasocut BC 35 Kombi SW ITER_D_HY3BCT	✓	✓	✓	✓	✗	✗	✗	✗
	Blasocut Kombi 935 MAR: ITER_D_RGD6JH Chemical analysis ITER_D_RZKU4T Safety datasheet ITER_D_=RGCLWS	✓	✓	✓	✓	✓	✓	✓	✓
	Blasocut 4000 Cleaning: Remove with water or solvent wipes FAR ITER_D_N54G6D	✗	✗	✓	✓	✓	✓	✓	✓
	CASTROL SYNTILO 75 EF ITER_D_PVM8M6	✓	✗	✗	✗	✗	✗	✗	✗
	Garia 2608 S-12 https://user.iter.org/?uid=LXQXBA Only for use on non-vacuum facing surfaces (which must be protected) and all surfaces cleaned post machining.	†	✗	†	✗	✗	✗	✗	✗

KEY: ✓ = *accepted* for use. ✗ = *not accepted* for use. † = *accepted* for restricted use only

Type	Name / type	Applicable to Vacuum Quality Classification							
		1A	1B	2A	2B	3A	3B	4A	4B
	Green Star SINTOL MICRO ITER_D_Q3N7N7	†	×	×	×	×	×	×	×
	Thread Cutting Oil Jokisch Foam Cut ITER_D_PNPSKN	†	†	†	†	†	†	†	†
	Magicutsynth-g-50 ITER_D_N3Q69Y	×	×	†	†	†	†	†	†
	QUAKER 3755 BIO ITER_D_NR4E2J	×	×	†	†	†	†	†	†
	Metalsierra DF Metalworking fluid FAR:- ITER_D_RMNBXQ Chemical analysis ITER_D_RMLNX3 Product data sheet ITER_D_RKLNT9 Safety data sheet ITER_D_RKLN7	✓	✓	✓	✓	✓	✓	✓	✓

KEY: ✓ = *accepted* for use. × = not *accepted* for use. † = *accepted* for restricted use only

Type	Name / type	Applicable to Vacuum Quality Classification							
		1A	1B	2A	2B	3A	3B	4A	4B
Cutting fluids	SWISSCOOL 7722 FAR: ITER_D_NFJ2N8 Approved for the spider application only	†	†	†	†	†	†	†	†
	SWISSCOOL 7722 FAR:- ITER_D_TTWU7X Use accepted cleaning procedure	✓	✓	✓	✓	✓	✓	✓	✓
	Xtreme Cut 250 MAR:- https://user.iter.org/?uid=QT8QGH Chemical analysis:- https://user.iter.org/?uid=QQ6LSM Subject to accepted cleaning procedure	✗	✗	✓	✓	✓	✓	✓	✓
	Hangsterfer's S787 Cutting Fluid MAR: ITER_D_SGMMPE				✓	✓	✓	✓	✓
	Castrol CareCut S 600 MAR: ITER_D_UCWFVD	✓	✓	✓	✓	✓	✓	✓	✓

KEY: ✓ = *accepted* for use. ✗ = *not accepted* for use. † = *accepted* for restricted use only

Type	Name / type	Applicable to Vacuum Quality Classification							
		1A	1B	2A	2B	3A	3B	4A	4B
	HOCUT 795 MP MAR : ITER_D_TR7XRQ			✓	✓	✓	✓	✓	✓
	Hocut 795-H MAR : ITER_D_UDSBHL			✓	✓	✓	✓	✓	✓
	Blasocut BC 25 MD MAR : ITER_D_UFCFJC				✓	✓	✓	✓	✓
	Pentagon Coolcut S MAR : ITER_D_UJ8YF4			✓	✓	✓	✓	✓	✓
	Blasocut BC 35 Kombi MAR : ITER_D_U4EZRD	✓	✓	✓	✓	✓	✓	✓	✓
	MK_SOL_LUBE MAR : ITER_D_U4F3YE	✓	✓	✓	✓	✓	✓	✓	✓
	Hocut 795MP MAR : ITER_D_UVF5MT								

KEY: ✓ = *accepted* for use. ✗ = *not accepted* for use. † = *accepted* for restricted use only

Type	Name / type	Applicable to Vacuum Quality Classification							
		1A	1B	2A	2B	3A	3B	4A	4B
	Synergy 915 MAR : ITER_D_UXSKL9			✓	✓	✓	✓	✓	✓
	Trim Tap Heavy FAR ITER_D_N9XD58 SDS ITER_D_T3BGTK (manufacture of ITER-style vacuum flanges) Cleaning: Aqueous wash with Rebound 7 followed by DI water rinse	✓	✓	✓	✓	✓	✓	✓	✓

KEY: ✓ = *accepted* for use. ✗ = not *accepted* for use. † = *accepted* for restricted use only

Type	Name / type	Applicable to Vacuum Quality Classification							
		1A	1B	2A	2B	3A	3B	4A	4B
	Trim Tap Light FAR ITER_D_Q5UH9M SDS ITER_D_T3C35D (manufacture of ITER-style vacuum flanges) Cleaning: Aqueous wash with Rebound 7 followed by DI water rinse	✓	✓	✓	✓	✓	✓	✓	✓
Machining Coolant	Kool Mist Formula 78 (manufacture of ITER-style vacuum flanges) FAR ITER_D_RCAFRL SDS ITER_D_SYC4EU Cleaning: Aqueous wash with Rebound 7 followed by DI water rinse	✓	✓	✓	✓	✓	✓	✓	✓
	Oemeta Novamet 100 Coolant MAR : ITER_D_U8W2E5			✓	✓	✓	✓	✓	✓

KEY: ✓ = *accepted* for use. ✗ = *not accepted* for use. † = *accepted* for restricted use only

Type	Name / type	Applicable to Vacuum Quality Classification							
		1A	1B	2A	2B	3A	3B	4A	4B
	SemiSyn-200 Blue MAR : ITER_D_UVF66V			✓	✓	✓	✓	✓	✓
	Trim E206 (manufacture of ITER-style vacuum flanges) Cleaning: Aqueous wash with Rebound 7 followed by DI water rinse FAR ITER_D_RZEV86 SDS ITER_D_SZWMS6	✓	✓	✓	✓	✓	✓	✓	✓
Solvents	Nefras S2-80/120 Wiping of Dome divertor parts for degreasing after machining FAR ITER_D_JREV32	✓	✓	✓	✓	✓	✓	✓	✓
	PROSOLV HP Degreasing of Copper & Tungsten for IVT Phase I FAR ITER_D_ST35B5	✓	✓	✓	✓	✓	✓	✓	✓

KEY: ✓ = *accepted* for use. ✗ = *not accepted* for use. † = *accepted* for restricted use only

Type	Name / type	Applicable to Vacuum Quality Classification							
		1A	1B	2A	2B	3A	3B	4A	4B
Acids	Nitric acid (65%) FAR https://user.iter.org/?uid=PNAPTE https://user.iter.org/?uid=PNHPFU https://user.iter.org/?uid=PQA6AW	✓	✓	✓	✓	✓	✓	✓	✓
	Sulphuric Acid (20% solution) FAR https://user.iter.org/?uid=PJRKC5 https://user.iter.org/?uid=PK32SY https://user.iter.org/?uid=PKZE6A	✓	✓	✓	✓	✓	✓	✓	✓
	Nitric Acid Concentrated FAR https://user.iter.org/?uid=D29SZG https://user.iter.org/?uid=CZMVE5 https://user.iter.org/?uid=DBQPL9 https://user.iter.org/?uid=DBQPL9	†	†	†	†	†	†	†	†

KEY: ✓ = *accepted* for use. ✗ = *not accepted* for use. † = *accepted* for restricted use only

Type	Name / type	Applicable to Vacuum Quality Classification							
		1A	1B	2A	2B	3A	3B	4A	4B
Acids	Hydrofluoric acid (in the manufacture of Divertor components prior to HIP) FAR https://user.iter.org/?uid=JQH3BW https://user.iter.org/?uid=JQH73T https://user.iter.org/?uid=JQHPHU	†	†	†	†	†	†	†	†
Alkaline solution	ALCATUM / ALCATUM HO Degreasing of Copper & Tungsten for IVT Phase I FAR ITER_D_STLR2W	✓	✓	✓	✓	✓	✓	✓	✓
Demin Water	Demin Water https://user.iter.org/?uid=N3PDHF	✓	✓	✓	✓	✓	✓	✓	✓
Etch and neutralise	Elektrolyt EH01 FAR https://user.iter.org/?uid=JEZ7DD	✓	✓	✓	✓	✗	✗	✗	✗
	Neutralix NG01 FAR https://user.iter.org/?uid=JF7ME6	†	†	†	†	†	†	†	†

KEY: ✓ = *accepted* for use. ✗ = *not accepted* for use. † = *accepted* for restricted use only

Type	Name / type	Applicable to Vacuum Quality Classification							
		1A	1B	2A	2B	3A	3B	4A	4B
Lubricant	APIEZON Medium Temperature Approved for VQC N/A only MAR : ITER_D_TF84U8								
Pickling and passivation	Avesta Passivator 601 FAR:- https://user.iter.org/?uid=NVPBLQ Datasheets:- https://user.iter.org/?uid=NW5VLQ https://user.iter.org/?uid=P3WC76 Subject to accepted cleaning procedure	✓	✓	✓	✓	✓	✓	✓	✓
	Avesta Cleaner 401 FAR:- https://user.iter.org/?uid=NSE9MN Datasheets:- https://user.iter.org/?uid=NSEM4 https://user.iter.org/?uid=NSH4DX Subject to accepted cleaning procedure	✓	✓	✓	✓	✓	✓	✓	✓

KEY: ✓ = *accepted* for use. ✗ = *not accepted* for use. † = *accepted* for restricted use only

Type	Name / type	Applicable to Vacuum Quality Classification							
		1A	1B	2A	2B	3A	3B	4A	4B
Pickling and passivation	Avesta pickling paste BlueOne TM 130 FAR:- https://user.iter.org/?uid=NQ4Y7N Datasheets:- https://user.iter.org/?uid=NQTMJC https://user.iter.org/?uid=NS77X8 Subject to accepted cleaning procedure	✓	✓	✓	✓	✓	✓	✓	✓
	HC 1100 Passivation solution for Stainless Steel (cryogenic piping for the pre-production cryopump) FAR:- ITER_D_RXJZB7 Datasheet :- ITER_D_RYMSKU	✓	✓	✓	✓	✓	✓	✓	✓

KEY: ✓ = *accepted* for use. ✗ = not *accepted* for use. † = *accepted* for restricted use only

Type	Name / type	Applicable to Vacuum Quality Classification							
		1A	1B	2A	2B	3A	3B	4A	4B
	HC 1100-K3W1 Stainless steel passivator (cryogenic piping for the pre-production cryopump) FAR ITER_D_RZ5MBE MDS ITER_D_RZ7JP4 SDS ITER_D_RZK5GK Cleaning procedures ITER_D_S2FG8X to be used	✓	✓	✓	✓	✓	✓	✓	✓
	VK Jelly / VK Jelly – Power / VK Spray / VK Spray – 1000 FAR:- https://user.iter.org/?uid=RUGXSS			✓	✓	✓	✓	✓	✓
	Edelshahlbeize Typ 14 MAR : ITER_D_U7VKQS	✓	✓	✓	✓	✓	✓	✓	✓
	K-2 Jelly / K-2 Jelly – Power / K-2 Spray / K-2 Paste FAR:- ITER_D_RVVJ9S			✓	✓	✓	✓	✓	✓

KEY: ✓ = *accepted* for use. ✗ = not *accepted* for use. † = *accepted* for restricted use only

Type	Name / type	Applicable to Vacuum Quality Classification							
		1A	1B	2A	2B	3A	3B	4A	4B
	PROCAP 137 FAR:- ITER_D_STGBAW Use with approved cleaning procedure	✓	✓	✓	✓	✓	✓	✓	✓
Liquid Penetrant families	Sherwin Inc. USA: NDT Europa BV: Developer: D100 Cleaner: DR62 Penetrant: DP51 <i>For VQC 1A/B This product is restricted and may only be used if component / system under test is subsequently baked at $T \geq 200$ °C for a minimum of 24 hours prior to vacuum leak testing.</i> <i>For VCQ2A, 3A& 4A this product may only be used to accepted procedures on the prior acceptance of a deviation request from the ITER Vacuum Handbook to cover the proposed area of use.</i>	†	†	†	✓	†	✓	†	✓

KEY: ✓ = accepted for use. ✗ = not accepted for use. † =accepted for restricted use only

Type	Name / type	Applicable to Vacuum Quality Classification							
		1A	1B	2A	2B	3A	3B	4A	4B
	DR60 as remover of dye penetrant FAR ITER_D_S7UXTC Accepted for this application on basis of post-use impregnation processes. Other uses will require approved cleaning process	x	x	✓	✓	x	x	x	x

KEY: ✓ = *accepted* for use. x = *not accepted* for use. † = *accepted* for restricted use only

Type	Name / type	Applicable to Vacuum Quality Classification							
		1A	1B	2A	2B	3A	3B	4A	4B
	<p>CGM CIGIEMME</p> <p>Developer : Rotrivel U (R2.82) 02011200 Cleaner: Velnet / Solnet (R2.60) 02011000 Penetrant: Rotvel Avio B (R2.72) 02021800</p> <p><i>For VQC 1A/B This product is restricted and may only be used if component / system under test is subsequently baked at $T \geq 200$ °C for a minimum of 24 hours prior to vacuum leak testing.</i></p> <p><i>For VQC 2A, 3A & 4A this product may only be used to accepted procedures on the prior acceptance of a deviation request from the ITER Vacuum Handbook to cover the proposed area of use.</i></p>								
		†	†	†	✓	†	✓	†	✓

EY: ✓ = accepted for use. ✗ = not accepted for use. † =accepted for restricted use only

Type	Name / type	Applicable to Vacuum Quality Classification							
		1A	1B	2A	2B	3A	3B	4A	4B
	<p>GS CHEM Co LTD</p> <p>Developer: DA (P101017D) Cleaner: RA (P101015C) Penetrant: PA (P101016P)</p> <p><i>For VQC 1A/B This product is restricted and may only be used if component / system under test is subsequently baked at T ≥ 200 °C for a minimum of 24 hours prior to vacuum leak testing.</i></p> <p><i>For VCQ2A, 3A& 4A this product may only be used to accepted procedures on the prior acceptance of a deviation request from the ITER Vacuum Handbook to cover the proposed area of use.</i></p>	†	†	†	✓	†	✓	†	✓

KEY: ✓ = accepted for use. ✗ = not accepted for use. † =accepted for restricted use only

Type	Name / type	Applicable to Vacuum Quality Classification							
		1A	1B	2A	2B	3A	3B	4A	4B
	<p>EISHINKAGAKU corp. Japan Developer: R-1S (NT) Special Cleaner: R-1M (NT) Special Penetrant: R-1A (NT) Special <i>For VQC 1A/B This product is restricted and may only be used if component / system under test is subsequently baked at $T \geq 200$ °C for a minimum of 24 hours prior to vacuum leak testing.</i> <i>For VCQ2A, 3A & 4A this product may only be used to accepted procedures on the prior acceptance of a deviation request from the ITER Vacuum Handbook to cover the proposed area of use.</i></p>	†	†	†	✓	†	✓	†	✓

KEY: ✓ = accepted for use. ✗ = not accepted for use. † = accepted for restricted use only

Type	Name / type	Applicable to Vacuum Quality Classification							
		1A	1B	2A	2B	3A	3B	4A	4B
	<p>MAGNAFLUX Dye penetrant testing of Tungsten monoblocks for ITER IVT https://user.iter.org/?uid=JP6EW8</p> <p>Penetrant: Zyglo ZL-27A, fluorescent post emulsifiable penetrant Cleaner: Zyglo ZR-10C, hydrophilic remover Developer: Zyglo ZP-4B, dry powder developer</p> <p>Fluid to be removed by hot demineralised water rinse followed by baking.</p>	†	†	†	†	†	†	†	†
Ultra Sonic Testing (UT) coupling fluids	<p>Babb Co matrix UT coupling agent FAR https://user.iter.org/?uid=PTZ2WR https://user.iter.org/?uid=PUW2LU</p> <p>Part to be cleaned to an accepted procedure after UT</p>	†	†	†	†	†	†	†	†
	<p>CGM US Paste U49</p> <p>FAR https://user.iter.org/?uid=PUXQHP https://user.iter.org/?uid=PVAE22</p> <p>Remove residues with clean cloth and acetone.</p>	†	†	†	†	†	†	†	†

KEY: ✓ = *accepted* for use. ✗ = *not accepted* for use. † = *accepted* for restricted use only

Type	Name / type	Applicable to Vacuum Quality Classification							
		1A	1B	2A	2B	3A	3B	4A	4B
Ultra-Sonic Testing (UT) coupling fluids	09060, Rock Oil, Vacuum test data https://user.iter.org/?uid=RRAZ87 ITER_D_RMSL86	✓	✓	✓	✓	✓	✓	✓	✓
	Dodecane, 297879, Sigma-Aldrich Vacuum test data ITER_D_RRAZ87 ITER_D_RMSL86	✓	✓	✓	✓	✓	✓	✓	✓
	Soundclear Grade 60 MAR ITER_D_U2WF3L (can be recommended for use as component is baked)	✓	✓	✓	✓	✓	✓	✓	✓
	Soundclear Grade 40 MAR : ITER_D_U348TX (can be recommended for use as component is baked)	✓	✓	✓	✓	✓	✓	✓	✓

KEY: ✓ = *accepted* for use. ✗ = *not accepted* for use. † = *accepted* for restricted use only

Type	Name / type	Applicable to Vacuum Quality Classification							
		1A	1B	2A	2B	3A	3B	4A	4B
	Pentagon Ultra 30 for use as UT couplant (approved for this application only, on basis of post -use surface removal by machining) MAR: ITER_D_UVC2BJ			✓					
	MR 750 Ultrasonic Coupling Agent FAR:- ITER_D_TX5XPV Cleaning as per ITER approved procedure document no. ITER CR- LTTS-602.	✓	✓	✓	✓	✓	✓	✓	✓

KEY: ✓ = *accepted* for use. ✗ = not *accepted* for use. † = *accepted* for restricted use only

Type	Name / type	Applicable to Vacuum Quality Classification								
		1A	1B	2A	2B	3A	3B	4A	4B	
Markers	Intrama SL.250 SL2100 MAR https://user.iter.org/?uid=QZSP86 Outgassing test report_MarkerPen_Intrama.SL.250 https://user.iter.org/?uid=QXVLSU Outgassing test report_MarkerPen_Intrama.SL.2100 https://user.iter.org/?uid=QXM5QJ Material acceptance report https://user.iter.org/?uid=HK7F54 Subject to accepted cleaning procedure	✓	✓	✓						
	Markal Certified Valve Action Paint Marker MAR : ITER_D_UBF44E (Certified for <200ppm halogen - agreed but should not be used on thin wall boundaries with material < 1.5mm.)			✓	✓					

KEY: ✓ = *accepted* for use. ✗ = not *accepted* for use. † = *accepted* for restricted use only

Type	Name / type	Applicable to Vacuum Quality Classification							
		1A	1B	2A	2B	3A	3B	4A	4B
	Edding 750 White, Silver & Blue FAR:- ITER_D_AFEQ97 Cleaning as per approved procedure ; ITER-CR-LTTS-602			✓	✓	✓	✓	✓	✓
Protective paint (on material processing equipment)	Stratomet Protective paint FAR:- ITER_D_R7TFB7 Chemical analysis:- ITER_D_R6CD9Z Safety data sheet:- ITER_D_R6CCRZ	✓	✓	✓	✓	✓	✓	✓	✓
Abrasive media	Cutting wheel Abratec TIPO 42 MAR:- https://user.iter.org/?uid=QZRF3E Outgassing report :- https://user.iter.org/?uid=GGREMQ Subject to accepted cleaning procedure	✓	✓	✓	✓	✓	✓	✓	✓

KEY: ✓ = *accepted* for use. ✗ = *not accepted* for use. † = *accepted* for restricted use only

Type	Name / type	Applicable to Vacuum Quality Classification							
		1A	1B	2A	2B	3A	3B	4A	4B
	Cutting wheel: Sait "A30S" [Thk. 2 mm] MAR:- https://user.iter.org/?uid=QURJQL Outgassing report:- https://user.iter.org/?uid=HK7F54 Subject to accepted cleaning procedure	✓	✓	✓	✓	✓	✓	✓	✓
	Cutting wheel: Sait "XA24Q" [Thk. 3,2 mm] MAR:- https://user.iter.org/?uid=QURJQL Outgassing report:- https://user.iter.org/?uid=HK7F54 Subject to accepted cleaning procedure	✓	✓	✓	✓	✓	✓	✓	✓

]

KEY: ✓ = *accepted* for use. ✗ = not *accepted* for use. † = *accepted* for restricted use only

Type	Name / type	Applicable to Vacuum Quality Classification							
		1A	1B	2A	2B	3A	3B	4A	4B
	Cutting wheel: Sait “XA24Q” [Thk. 7 mm] MAR:- https://user.iter.org/?uid=QURJQL Outgassing report:- https://user.iter.org/?uid=HK7F54 Subject to accepted cleaning procedure	✓	✓	✓	✓	✓	✓	✓	✓
	Cutting wheel: Sait “XA46R” [Thk. 1,6 mm] MAR:- https://user.iter.org/?uid=QURJQL Outgassing report:- https://user.iter.org/?uid=HK7F54 Subject to accepted cleaning procedure	✓	✓	✓	✓	✓	✓	✓	✓
	Flapper wheel: Abratec LAMELLARE MAR:- https://user.iter.org/?uid=QZRF3E Outgassing report:- https://user.iter.org/?uid=GJ584M Subject to accepted cleaning procedure	✓	✓	✓	✓	✓	✓	✓	✓

KEY: ✓ = *accepted* for use. ✗ = not *accepted* for use. † = *accepted* for restricted use only

Type	Name / type	Applicable to Vacuum Quality Classification							
		1A	1B	2A	2B	3A	3B	4A	4B
	Flapper wheel: Sait "SAITLAM UK 3A" MAR:- https://user.iter.org/?uid=QURJQL Outgassing report:- https://user.iter.org/?uid=HK7F54 Subject to accepted cleaning procedure	✓	✓	✓	✓	✓	✓	✓	✓
	Flapper wheel; S.L.F. Abrasivi LASER DISC – "SERIE 10-ALU DISC" MAR:- https://user.iter.org/?uid=QURJQL Outgassing report:- https://user.iter.org/?uid=HK7F54 Subject to accepted cleaning procedure	✓	✓	✓	✓	✓	✓	✓	✓
	Rough Wheel: Abratec TIPO 27 MAR:- https://user.iter.org/?uid=QZRF3E Outgassing report ;- https://user.iter.org/?uid=HD5Z3U Subject to accepted cleaning procedure	✓	✓	✓	✓	✓	✓	✓	✓

KEY: ✓ = *accepted* for use. ✗ = *not accepted* for use. † = *accepted* for restricted use only

Type	Name / type	Applicable to Vacuum Quality Classification							
		1A	1B	2A	2B	3A	3B	4A	4B
	Rough Wheel: 3M “987C CUBITRON 2” MAR:- https://user.iter.org/?uid=QURJQL Outgassing report:- https://user.iter.org/?uid=HK7F54 Subject to accepted cleaning procedure	✓	✓	✓	✓	✓	✓	✓	✓
	Klingspor KL 361 Abrasive paper. PMUC 10067 FAR:- ITER_D_TXD2ZJ Cleaning with alcohol after usage	✓	✓	✓	✓	✓	✓	✓	✓
	3M Roloc Disc 984F Abrasive Disc FAR:- ITER_D_4H8PDW Area to be cleaned with solvent after processing	✓	✓	✓	✓	✓	✓	✓	✓
	3M Cloth Belts 984F Abrasive Belt for belt grinder FAR:- ITER_D_4HBVE3 Must be followed by cleaning procedure	✓	✓	✓	✓	✓	✓	✓	✓

KEY: ✓ = *accepted* for use. ✗ = not *accepted* for use. † = *accepted* for restricted use only

Type	Name / type	Applicable to Vacuum Quality Classification							
		1A	1B	2A	2B	3A	3B	4A	4B
	3M™ Abrasive Products, High Performance Cut off Wheels, Depressed Center Grinding Wheels, Grind Wheels Type 27, Cubitron™ II FAR:- ITER_D_4HD79D Must be followed by cleaning procedure	✓	✓	✓	✓	✓	✓	✓	✓
	3M Flap Disc 967A Flap disc FAR:- ITER_D_T79GNQ Area to be cleaned with solvent after operations with flapper	✓	✓	✓	✓	✓	✓	✓	✓
	3M XT-RD-Cleaning Disc FAR:- ITER_D_4H3ZHJ Must be followed by cleaning with solvent	✓	✓	✓	✓	✓	✓	✓	✓
	Tungsten carbide burrs Lukas Abrasive Pencil FAR:- ITER_D_T8FBAG	✓	✓	✓	✓	✓	✓	✓	✓
	Stainless steel brush FAR:- ITER_D_T8FUKG	✓	✓	✓	✓	✓	✓	✓	✓
	Paper KL361 grain 240, grain 120 and grain 80 ; Grinding tool RB 317 LX-R grain 80 FAR : ITER_D_UAMCD5	✓							

KEY: ✓ = *accepted* for use. ✗ = *not accepted* for use. † = *accepted* for restricted use only

Type	Name / type	Applicable to Vacuum Quality Classification							
		1A	1B	2A	2B	3A	3B	4A	4B
	Tetrabor lapping paste (water/polyalcohol based) FAR:- https://user.iter.org/?uid=QF6X54 Datasheets:- Safety https://user.iter.org/?uid=QED2DQ https://user.iter.org/?uid=QEJ42W https://user.iter.org/?uid=QERFGW https://user.iter.org/?uid=QF2HJZ https://user.iter.org/?uid=QEH9AG https://user.iter.org/?uid=QF7K99 Subject to accepted cleaning procedure	✓	✓	✓	✓	✓	✓	✓	✓

KEY: ✓ = *accepted* for use. ✗ = not *accepted* for use. † = *accepted* for restricted use only

Type	Name / type	Applicable to Vacuum Quality Classification							
		1A	1B	2A	2B	3A	3B	4A	4B
	HE 111 Electrolytic polisher (cryogenic piping for the pre-production cryopump) FAR ITER_D_RN4QKV Cleaning procedures ITER_D_S2FG8X to be used SDS ITER_D_RN6FUA	✓	✓	✓	✓	✓	✓	✓	✓
	HE 310 Electrolytic Polisher (cryogenic piping for the pre-production cryopump) FAR ITER_D_RYS3HQ SDS ITER_D_RYTRXG Cleaning procedures ITER_D_S2FG8X to be used	✓	✓	✓	✓	✓	✓	✓	✓

KEY: ✓ = *accepted* for use. ✗ = not *accepted* for use. † = *accepted* for restricted use only

Type	Name / type	Applicable to Vacuum Quality Classification							
		1A	1B	2A	2B	3A	3B	4A	4B
Adhesive tapes	3M™ Aluminum Foil Tape 431 FAR:- ITER_D_R23U88 For use on VQC N/A surfaces only with solvent clean. Before use on higher VQC categories, verification of full cleaning process cleaning required on sample coupons								
	3M™ Preservation sealing Tape 481 FAR:- ITER_D_R24JEX For use on VQC N/A surfaces only with solvent clean. Before use on higher VQC categories, verification of full cleaning process cleaning required on sample coupons								

KEY: ✓ = *accepted* for use. ✗ = not *accepted* for use. † = *accepted* for restricted use only

Type	Name / type	Applicable to Vacuum Quality Classification							
		1A	1B	2A	2B	3A	3B	4A	4B
Adhesive tapes	Delvigo DVC 48040/7 A5 weld backing strip FAR:- ITER D R477ZK For use on VQC N/A surfaces only with solvent clean. Before use on higher VQC categories, verification of full cleaning process cleaning required on sample coupons								
	Delvigo DVC 44040/6 A5 weld backing strip FAR:- ITER D R25TST For use on VQC N/A surfaces only with solvent clean. Before use on higher VQC categories, verification of full cleaning process cleaning required on sample coupons								

KEY: ✓ = *accepted* for use. ✗ = not *accepted* for use. † = *accepted* for restricted use only

Type	Name / type	Applicable to Vacuum Quality Classification							
		1A	1B	2A	2B	3A	3B	4A	4B
	Scapa 336 Aluminium adhesive tape FAR:- ITER_D_R4AZFV For use on VQC N/A surfaces only with solvent clean. Before use on higher VQC categories, verification of full cleaning process cleaning required on sample coupons								
	AveryDennison HP MPI 2121 MAR : ITER_D_UDWANR (Recommended as component is cleaned and baked after use)	✓							
	Tesa 4613 – Utility grade Duct Tape (use of cryostat) MAR : ITER_D_UPXQCQ (Ok for VQC 2 but avoid to use on thin walled bellows or lips <1.5 mm thick)			✓					

KEY: ✓ = *accepted* for use. ✗ = not *accepted* for use. † = *accepted* for restricted use only

Type	Name / type	Applicable to Vacuum Quality Classification							
		1A	1B	2A	2B	3A	3B	4A	4B
	3M 425 & 431 Aluminium Foil Tape FAR: ITER_D_U33P6M			✓	✓	✓	✓	✓	✓
Handling / transport materials	Kraitec anti-slip elastomer pads FAR:- ITER_D_4GRXXK	✓	✓	✓	✓	✓	✓	✓	✓
Adhesives	Adhesive Technologies Glue Stick, Part 229 MAR : ITER_D_UHDX7N (glue pucks for laser tracking to tie plate)			✓	✓				
	TACKY TAPE SM5142 (vacuum bag tape sealant) MAR : ITER_D_TX66XF			✓					

KEY: ✓ = *accepted* for use. ✗ = not *accepted* for use. † = *accepted* for restricted use only

<i>Request for Acceptance of Fluid</i>					Ref No: fluid-01 <i>(Assigned by Vacuum RO)</i>					
Fluid submitted for <i>acceptance</i> :		Cut ace 123								
Proposed Use:		Metal Cutting fluid								
VQC of proposed use:		1A	1B	2A	2B	3A	3B	4A	4B	
		✓								
Chemical Composition / suppliers data sheet		Yes	<i>Attached Copy (electronic if available)</i>							
Agreed test plan:		No	<i>Attached Copy (electronic if available)</i>							
Vacuum Test data Available:		Yes	<i>Attached Copy (electronic if available)</i>							
Solubility in water (at ambient temperature)										
Cleaning method (if applicable)		Rinse in de mineralised water								
Vapour pressure (at 100 °C)		No	Pa							
Supporting information		Evaporates in air leaving oily residue								
Requested by		L.Pressure			Date Submitted		29/07/08			
Affiliation:		US DA			E-Mail	L.Pressure@iter.org				
Fluid Acceptance Status: (To be completes by ITER Vacuum Group RO)										
Acceptance for VQC:		1A	1B	2A	2B	3A	3B	4A	4B	
		✓	✓	✓	✓	✓	✓	✓	✓	
Limits / Restrictions (Attached Doc.)		Fluid to be removed by hot demineralised water rinse (Cut ace 123 .doc IDM Ref 15R8UI)								
ITER Vacuum RO		<i>Acceptor:</i>			H.M. Self					
		Date: 09/08/08								

Grey boxes to be completed by requesting officer. Boxes in Red to be completed by ITER Vacuum RO.

ITER Vacuum Handbook Appendix 5

Guideline (not under Configuration Control)

5. Acceptance Checklist

5.1. Scope

To satisfy the requirements of the ITER Vacuum Handbook *acceptance* or *accepted* is called for in various places throughout the ITER Vacuum Handbook.

Acceptance can be granted through the submission of procedures (etc.) or through the signed Procurement Arrangement as detailed in the ITER Vacuum Handbook.

This appendix is intended as a tool to manage the *acceptance* of the requirements as laid out in the ITER Vacuum Handbook and contains a list of all the items from the ITER Vacuum Handbook where *acceptance* is required.

An *acceptance* checklist can be completed for PAs by a representative of the ITER Vacuum Responsible Officer. On completion of the checklist, the reviewer can indicate where further *acceptance* is required for the PA to be in compliance with the requirements of the ITER Vacuum Handbook.

In the following table *acceptances* which are highlighted appear in similar form at more than one place in the Handbook. The main occurrence for each group is highlighted in the table in *blue* and subsequent occurrences are highlighted in dark *yellow*. A single acceptance is then valid for the whole group of *acceptances*.

#	ITER Vacuum Handbook Section Reference	<i>Acceptance</i>	Proc.	PA	Note
1	5 - Appendix 3	Only materials <i>accepted</i> to be used on ITER Vacuums	<input type="checkbox"/>	<input type="checkbox"/>	Materials listed in Appendix 3 can be used subject to their classification / restriction as described in Appendix 2. Other materials may be used once qualified as <i>acceptable</i> . Requires <i>acceptance</i> of qualification plan. <i>Mandatory for all materials not listed in Appendix 3.</i>
2	5.3 - Metallic Machined Components and Fittings	Other forms of achieving low inclusion count material may be used	<input type="checkbox"/>	<input type="checkbox"/>	If a supplier has a process other than ESR or VAR to produce low inclusion material this method must be <i>accepted</i> . <i>Mandatory if ESR or VAR is not used in the production of low inclusion material.</i>
3	5.4 - Outgassing	Novel, high surface area components require <i>acceptance</i>	<input type="checkbox"/>	<input type="checkbox"/>	The supplier must submit for review and <i>acceptance</i> a method by which components can be shown to conform to the requirements of the ITER Vacuum Handbook. Published data and /or experimental qualification may be used. <i>Mandatory if novel high surface area components are used.</i>

#	ITER Vacuum Handbook Section Reference	<i>Acceptance</i>	Proc.	PA	Note
4	VH 5.4 - outgassing	Outgassing rate <i>acceptance</i> test to be performed on VQC 1 components	<input type="checkbox"/>	<input type="checkbox"/>	<p>The supplier shall submit to the ITER Vacuum RO the <i>acceptance</i> test procedure for review and <i>acceptance</i>. This <i>acceptance</i> may also allow for testing of representative samples of components. Procedures should pay due regard to Appendix 17. For specific components, it may be agreed that conformity to a clean work and quality plan is <i>acceptable</i>.</p> <p><i>Mandatory for all VQC 1 components except if operation in vacuum above 1 Pa in which case the ITER Vacuum RO will assess the use and accept the component on a case by case basis.</i></p>
5	5.5 - Hot Isostatic Pressing	<i>Acceptance</i> at the design stage for the use of HIP formed components and <i>acceptance</i> of qualification procedure of such components	<input type="checkbox"/>	<input type="checkbox"/>	<p>The use of HIP formed material <i>accepted</i> at the design stage. The ITER Vacuum RO shall also review and <i>accept</i> the procedure for qualification of such components to demonstrate that they conform to the requirements of the ITER Vacuum Handbook.</p> <p><i>Mandatory for components formed by Hot Isostatic Pressing.</i></p>
6	5.6 - Castings	Validation programme for the qualification of castings to show they conform to the VH shall be <i>accepted</i> by the ITER Vacuum RO	<input type="checkbox"/>	<input type="checkbox"/>	<p>If a casting is required for use on systems with VQC = 1, 2A or 3 a qualification programme (to show that they conform to the requirements of the ITER Vacuum Handbook) shall be reviewed and <i>accepted</i>.</p> <p><i>Mandatory for castings with VQC =1, 2A or 3.</i></p>

#	ITER Vacuum Handbook Section Reference	Acceptance	Proc.	PA	Note
7	6.1.2 - VQC 1 & 3 cutting fluids	Cutting fluids not listed in Appendix 4 require <i>acceptance</i> .	<input type="checkbox"/>	<input type="checkbox"/>	Cutting fluids listed in Appendix 4 can be used subject to their classification / restriction as described in Appendix 4. Other cutting fluids may be used once qualified as <i>acceptable</i> . Requires <i>acceptance</i> of qualification plan. <i>Mandatory for cutting fluids not listed in Appendix 4.</i>
8	7 - Permanent joining processes	Permanent joining processes not listed in Table 7.1 require <i>acceptance</i>	<input type="checkbox"/>	<input type="checkbox"/>	The supplier shall submit proposals for other permanent joining processes not listed to be <i>accepted</i> . <i>Mandatory for all permanent joining processes not listed in table 7.1.</i>
9	7.1.1 - Joint Configuration	Welds for which at completion leak detection is not practical require that a test plan including provision for repair shall be <i>accepted</i> .	<input type="checkbox"/>	<input type="checkbox"/>	Where welds are not leak testable the supplier must submit for review and <i>acceptance</i> at the design stage a test plan which also details how such a weld could be repaired if it fails. <i>Mandatory for welds which cannot be tested at the time of manufacture.</i>
10	7.1.4 - Inspection and Testing of Production welds	The selection process for codes which <i>require</i> the use of LPT for the build of vacuum equipment shall be recorded and <i>accepted</i> .	<input type="checkbox"/>	<input type="checkbox"/>	If there is a mandatory requirement (such as nuclear regulator) to <i>build</i> a vacuum system to a code which requires the use of LPT to satisfy the code then the selection of that code shall be <i>accepted</i> . <i>Mandatory only where there is, for example, a regulatory requirement to <u>build</u> a vacuum system to a code and only then if the code requires the use of LPT without exception.</i>

#	ITER Vacuum Handbook Section Reference	Acceptance	Proc.	PA	Note
11	7.1.4 - Inspection and Testing of Production welds	If LPT is to be used then it must be used only according to procedures qualified and <i>accepted</i>	<input type="checkbox"/>	<input type="checkbox"/>	The supplier shall submit for <i>acceptance</i> a procedure for the use of ITER qualified LDP. This shall include how the LDP is removed from the surface. <i>Mandatory when LDP is used.</i>
12	7.1.5 - Weld Finish & Repair	Weld repairs shall be carried out to <i>accepted</i> procedures	<input type="checkbox"/>	<input type="checkbox"/>	The supplier shall submit for review and <i>acceptance</i> of weld repairs on vacuum boundary components. <i>Only mandatory for welds not produced to a code (e.g. RCC-MR – ASME 8).</i>
13	7.1.6 - Helium Leak Testing of Production Welds.	Procedure for helium leak testing to be <i>accepted</i> .	<input type="checkbox"/>	<input type="checkbox"/>	The supplier shall submit for review and <i>acceptance</i> a procedure detailing how the helium leak testing of production welds shall be carried out and details of the equipment to be used <i>Mandatory for all vacuum welds. Accepted with #45</i>
14	7.2 - Brazed and soldered joints	Brazing flux is not normally permitted	<input type="checkbox"/>	<input type="checkbox"/>	If brazing flux is required for use on vacuum systems a procedure for cleaning the components shall be submitted for review and <i>acceptance</i> . <i>Only required if brazing flux is to be used.</i>
15	7.2 - Brazed and soldered joints	The use of brazing materials containing silver is subject to quotas	<input type="checkbox"/>	<input type="checkbox"/>	Specific acceptance is required for use of silver bearing braze materials on any individual component <i>Mandatory for all use of silver alloys in brazed joints except in VQC4</i>

#	ITER Vacuum Handbook Section Reference	Acceptance	Proc.	PA	Note
16	7.2 - Brazed and soldered joints	Brazing should be performed to an <i>accepted</i> standard or to an <i>accepted</i> procedure.	<input type="checkbox"/>	<input type="checkbox"/>	If brazing is required the supplier shall submit for review and <i>acceptance</i> either a procedure detailing how the brazing operations are qualified and produced <i>or</i> an international brazing standard detailing the qualification and production procedure. <i>Mandatory for all brazing operations.</i>
17	7.2.2 - Qualification of brazed joints	The procedure for the qualification of brazed joints shall be <i>accepted</i> .	<input type="checkbox"/>	<input type="checkbox"/>	If brazing is required the qualification procedure shall be <i>accepted</i> <i>or</i> performed to an <i>accepted</i> international standard for brazing. <i>Mandatory for brazing operations. Acceptance can be granted with #16.</i>
18	7.2.3 – Inspection and testing of brazed joints	No braze shall be rerun for rectification of any sort without prior agreement	<input type="checkbox"/>	<input type="checkbox"/>	Procedure for any rerun to be agreed <i>Mandatory where rectification of a braze is required.</i>
19	7.3 – Diffusion bonding	Diffusion bonded joints shall be subject to the same qualification procedures as brazed joints	<input type="checkbox"/>	<input type="checkbox"/>	Note: Numbers 15-17 (inclusive) above apply <i>Mandatory for all diffusion bonded joints.</i>
20	7.3 – Explosion bonding	Explosion bonded joints shall be subject to the same qualification procedures as brazed joints	<input type="checkbox"/>	<input type="checkbox"/>	Note: Numbers 15-17 (inclusive) above apply <i>Mandatory for all explosion bonded joints.</i>

21	8.2 - Coatings	VQC 1 coatings subject to qualification and <i>acceptance</i> .	<input type="checkbox"/>	<input type="checkbox"/>	The supplier must provide for review and <i>acceptance</i> a method for the qualification of coatings. <i>Mandatory only for VQC1.</i>
----	----------------	---	--------------------------	--------------------------	--

#	ITER Vacuum Handbook Section Reference	<i>Acceptance</i>	Proc.	PA	Note
22	9 - Confinement and Vacuum Containment	Single containment of VQC 1A vulnerable components may be <i>accepted</i> if the component is accessible for access and fitted behind an <i>accepted</i> , interlocked, isolating valve.	<input type="checkbox"/>	<input type="checkbox"/>	Details of single vacuum contained VQC 1A shall be supplied for review and <i>acceptance</i> at the design stage. <i>Mandatory only for VQC1A components.</i>
23	9 - Confinement and Vacuum Containment	Single containment of VQC 2A components.	<input type="checkbox"/>	<input type="checkbox"/>	For Vulnerable VQC 2A components, which are not doubly vacuum contained, an alternative method for leak mitigation and localisation shall be submitted for review and <i>acceptance</i> at the design stage. <i>Mandatory only for VQC2A components.</i>
24	11 - Connections to the SVS	All connections to the SVS shall be as defined in the VH with the exception of interspaces pumped to $P < 5 \times 10^{-1}$ Pa	<input type="checkbox"/>	<input type="checkbox"/>	The supplier shall submit for <i>acceptance</i> the detailed design of interspaces for connection to the SVS for interspaces where the required pressure is $< 5 \times 10^{-1}$ Pa. <i>Mandatory for all SVS connections of this type.</i>
25	12.1 - Pipework General	VQC 1A and VQC2A pipes and fittings shall be seamless	<input type="checkbox"/>	<input type="checkbox"/>	Specific <i>acceptance</i> is required for the use of non- seamless pipes and fittings on the vacuum boundary of VQC1 and 2 systems. <i>Mandatory for VQC 1A and VQC 2A.</i>

26	12.1 - Pipework General	Water pipes passing through the cryostat shall have interspaces for leak localization	<input type="checkbox"/>	<input type="checkbox"/>	Where water pipes passing through the cryostat are not installed with interspaces for leak localisation an alternative method of localisation shall be proposed for review and <i>acceptance</i> . <i>Mandatory for all water pipes crossing the cryostat.</i>
----	----------------------------	---	--------------------------	--------------------------	--

#	ITER Vacuum Handbook Section Reference	<i>Acceptance</i>	Proc.	PA	Note
27	13 - Demountable Joints	All demountable joints require <i>acceptance</i>	<input type="checkbox"/>	<input type="checkbox"/>	The supplier shall provide details of proposed type and configuration of demountable vacuum joints (including seals) for use on ITER vacuum systems. <i>Requirement is diminished if standard demountable vacuum joints are selected from Appendix 8.</i>
28	13 - Demountable joints	VQC 4 demountable vacuum joints shall use all-metal seals	<input type="checkbox"/>	<input type="checkbox"/>	If all metal seals are not to be used on VQC 4 systems a proposal for other types of seal shall be submitted for review and <i>acceptance</i> . <i>Requirement for VQC 4.</i>
29	13 - Demountable joints	All demountable joints to be helium leak tested to <i>accepted</i> installation procedures	<input type="checkbox"/>	<input type="checkbox"/>	The supplier shall submit for review and <i>acceptance</i> installation procedure detailing how demountable vacuum joints are made (bolt torque, sequence etc). This procedure shall include leak testing of the made joint. <i>Mandatory for all demountable vacuum</i> <i>General approval of leak testing techniques (only) may be made with #52</i>
30	14.1 – Tapped holes	Tapped holes to be cut using approved cutting fluids	<input type="checkbox"/>	<input type="checkbox"/>	Cutting fluids listed in Appendix 4 can be used subject to their classification / restriction as described in Appendix 4. Other cutting fluids may be used once qualified as <i>acceptable</i> . Requires <i>acceptance</i> of qualification plan. <i>Mandatory for cutting fluids not listed in Appendix 4.</i> <i>Acceptance will be granted with #7</i>

#	ITER Vacuum Handbook Section Reference	Acceptance	Proc.	PA	Note
31	14.2.2 - Prevention of Bolt Seizing	Dry lubricants to be selected from Appendix 3	<input type="checkbox"/>	<input type="checkbox"/>	If a lubricant is not listed in Appendix 3 then <i>acceptance</i> to use the proposed lubricant shall be sought. <i>Acceptance will be granted with #1.</i>
32	14.4 - Bearings and sliding joints	Design of bearings and sliding joints for use on VQC 1 to 3 subject to <i>acceptance</i>	<input type="checkbox"/>	<input type="checkbox"/>	The supplier shall submit for review and <i>acceptance</i> at the design stage proposals for the design of bearings and/or sliding joints for use on systems with VQC 1 to 3. <i>Excludes sliding joints used in VQC 4.</i>
33	14.4 Bearings and sliding joints	Type of cross linked PTFE requires <i>acceptance</i>	<input type="checkbox"/>	<input type="checkbox"/>	If Cross linked PTFE is to be used the supplier shall submit for review and <i>acceptance</i> details of the type of cross-linked PTFE, it's operational position and quantity. <i>Applicable to cross-linked PTFE for use on VQC 2 or 4.</i>
34	15.2 - Qualification of Windows	Qualification plan to be <i>accepted</i>	<input type="checkbox"/>	<input type="checkbox"/>	The supplier shall submit for review and <i>acceptance</i> a detailed plan for the qualification of window assemblies for use on a vacuum boundary. <i>Mandatory for all window assemblies.</i>
35	15.3 - Testing of Window Assemblies	Testing plan to be <i>accepted</i>	<input type="checkbox"/>	<input type="checkbox"/>	The supplier shall submit for review and <i>acceptance</i> a detailed plan for the testing of window assemblies manufactures to a procedure <i>accepted</i> in #29. <i>Mandatory for all window assemblies.</i>

#	ITER Vacuum Handbook Section Reference	<i>Acceptance</i>	Proc.	PA	Note
36	16 - Vacuum Valves and Valve Assemblies	Use of elastomers for closure seals	<input type="checkbox"/>	<input type="checkbox"/>	Where valves are to be used on VQC 2 and an elastomer closure seal is required the supplier shall provide details of the type of valve and it's operational position (etc) for review and <i>acceptance</i> . <i>Applicable to VQC 2 Valves only.</i>
37	16 - Vacuum Valves and Valve Assemblies	Use of compressed gas to maintain closure seal	<input type="checkbox"/>	<input type="checkbox"/>	Valves should not require compressed gas to maintain the closure seal. If it is required that a valve utilises compressed gas to maintain the closure seal, the type of valve, operational position, etc., shall be provided for review and <i>acceptance</i> . <i>Mandatory for all such valves.</i>
38	16.1 - Acceptance testing of Valves and Valve Assemblies	Valves to be leak tested to <i>accepted</i> procedures	<input type="checkbox"/>	<input type="checkbox"/>	The supplier shall submit for review and <i>acceptance</i> a leak test procedure to prove the leak integrity of valves prior to delivery. <i>Mandatory for all Valves, although can be waived for proprietary valves.</i> <i>General approval of leak testing techniques (only) may be made with #52</i>

39	17.1 - Bellows and Flexibles - General	Bellows in water circuits not allowed for any VQC unless by exception.	<input type="checkbox"/>	<input type="checkbox"/>	<p>If a bellows is required for use in a water circuit and is installed behind an isolating valve, the supplier shall provide for review and <i>acceptance</i> details of position, operational parameters, design etc.</p> <p><i>Mandatory for all bellows in water circuits inside vacuum systems.</i></p>
----	--	--	--------------------------	--------------------------	---

#	ITER Vacuum Handbook Section Reference	<i>Acceptance</i>	Proc.	PA	Note
40	17.2 - Design of Bellows	Bellows shall be designed to EJMA or equivalent.	<input type="checkbox"/>	<input type="checkbox"/>	If bellows are not to be designed using the EJMA design rules then an alternative set of rules shall be submitted, with a bellows qualification plan, for review and <i>acceptance</i> . <i>All non-proprietary Bellows.</i>
41	17.2 - Design of Bellows	The use of multilayer design requires <i>acceptance</i>	<input type="checkbox"/>	<input type="checkbox"/>	If vulnerable bellows used on VQC 1&2 systems are not of double wall construction then bellows of multilayer construction may be allowable if the multilayer design is <i>accepted</i> . <i>For VQC 1& 2 Vulnerable Bellows.</i>
42	17.3 - Qualification of bellows	Procedure for the qualification of bellows required	<input type="checkbox"/>	<input type="checkbox"/>	The supplier shall submit for review and <i>acceptance</i> a plan detailing the tests to be performed in the qualification of bellows assemblies. <i>For all non –proprietary bellows.</i>
43	17.4 - Testing and Inspection of Bellows	Procedure for the testing of bellows required	<input type="checkbox"/>	<input type="checkbox"/>	The supplier shall submit for review and <i>acceptance</i> a plan detailing the tests to be performed on the manufactured bellows assemblies. <i>For all non –proprietary bellows.</i>

44	VH 18.1 - Feedthroughs General	Vulnerable VQC1A and 2A feedthroughs penetrating an air boundary shall be doubly vacuum contained	<input type="checkbox"/>	<input type="checkbox"/>	If the feedthroughs are not to be doubly vacuum contained then the supplier shall submit for review and <i>acceptance</i> an alternative arrangement which will ensure sufficient vacuum integrity of the component. <i>VQC 1A&2A feedthroughs crossing an air boundary.</i>
----	-----------------------------------	--	--------------------------	--------------------------	---

#	ITER Vacuum Handbook Section Reference	Acceptance	Proc.	PA	Note
45	18.2 - Paschen breakdown	Choice of backfill gas in interspace where there is a risk of Paschen breakdown shall be <i>accepted</i>	<input type="checkbox"/>	<input type="checkbox"/>	The supplier shall agree which gas shall be used to backfill the interspace. <i>For interspaces at risk of Paschen breakdown only.</i>
46	20.1 - Cables for use in Vacuum	Cables that are not listed in Appendix 10 require <i>acceptance</i> for use in ITER vacuum systems.	<input type="checkbox"/>	<input type="checkbox"/>	The supplier shall submit for review and <i>acceptance</i> at the design stage details of proposed cables not listed in Appendix 10. <i>Applies to all VQC.</i>
47	20.1 - Cables for use in Vacuum	Qualification of cable manufacturing techniques	<input type="checkbox"/>	<input type="checkbox"/>	The supplier shall provide for review and <i>acceptance</i> a procedure for the manufacture and qualification of cables for use in ITER vacuum systems. <i>Applies to all VQC. Complementary to #41</i>
48	24.1 - Cleaning	Cleaning procedures to be agreed	<input type="checkbox"/>	<input type="checkbox"/>	The supplier shall submit for review and <i>acceptance</i> a clean work plan detailing the procedures and methods to be used in the cleaning of vacuum components for use on ITER. <i>Applies to all VQC.</i>
49	24.1 - Cleaning	Degreasing procedures	<input type="checkbox"/>	<input type="checkbox"/>	The supplier shall submit for review and <i>acceptance</i> a plan detailing the procedures and methods to be used in the degreasing of vacuum components for use on ITER. <i>Applies to all VQC. Accepted with #48</i>

50	24.3 - Mechanical Processes on Vacuum Surfaces	Use of abrasive techniques on vacuum surfaces	<input type="checkbox"/>	<input type="checkbox"/>	All such techniques require agreement before being used In VQC2 shot and dry bead blasting are acceptable <i>Mandatory for all VQC</i>
-----------	--	---	--------------------------	--------------------------	---

#	ITER Vacuum Handbook Section Reference	<i>Acceptance</i>	Proc.	PA	Note
51	24.3 - Mechanical Processes on Vacuum Surfaces	Use of grinding wheels	<input type="checkbox"/>	<input type="checkbox"/>	If a grinding wheel is to be used on components with VQC 1 then the details of the grinding wheel (composition, manufacturing process, etc.) shall be submitted for review and <i>acceptance</i> prior to the grinding wheel being used. <i>For VQC 1 only.</i>
52	25.1 - Leak testing General	Leak testing procedures require <i>acceptance</i>	<input type="checkbox"/>	<input type="checkbox"/>	Prior to any acceptance leak testing the supplier shall submit for review and <i>acceptance</i> a leak testing procedure detailing the methods , equipment to be used, etc, for acceptance leak testing. <i>Mandatory for all acceptance leak tests, for all VQC. May be waived for proprietary components supplied with C of C.</i>
53	25.4 - Scheduling of Leak Tests	Timing of tests	<input type="checkbox"/>	<input type="checkbox"/>	Prior to manufacture the supplier shall provide a leak test plan detailing the timing and type of leak tests to be performed. <i>Mandatory for all acceptance leak tests, for all VQC. May be waived for proprietary components supplied with C of C.</i>

<p>54</p>	<p>25.4 - Scheduling of Leak Tests</p>	<p>Derogation of acceptance leak testing of complete system.</p>	<p><input type="checkbox"/></p>	<p><input type="checkbox"/></p>	<p>For VQC 2A components where final acceptance leak testing of the system as a whole may be impractical the supplier shall submit for review and <i>acceptance</i> a procedure to leak test individual parts of the system and the method of scaling of such tests to the system whole. <i>VQC 2A components only. Accepted with #52.</i></p>
-----------	--	--	---------------------------------	---------------------------------	---

#	ITER Vacuum Handbook Section Reference	Acceptance	Proc.	PA	Note
55	25.5 - Methods and Procedures	Leak test procedures require acceptance	<input type="checkbox"/>	<input type="checkbox"/>	Full details required <i>Accepted with #52</i>
56	25.5 - Methods and Procedures	Cold leak testing	<input type="checkbox"/>	<input type="checkbox"/>	The supplier of a vacuum system which operates at cryogenic temperatures shall submit for <i>acceptance</i> a method of cold leak testing joints. <i>For all VQC. General approval of leak testing techniques (only) may be made with #52.</i>
57	25.6 - Acceptance leak testing at the suppliers Premises	Rectification of detected leak	<input type="checkbox"/>	<input type="checkbox"/>	If a leak is detected any rectification work (except remaking demountable joints) must be agreed in advance <i>All VQC</i>
58	25.6 - Acceptance leak testing at the suppliers Premises	Delivery to ITER of equipment which fails the acceptance leak test	<input type="checkbox"/>	<input type="checkbox"/>	If a component fails the acceptance leak test at the suppliers premises then the supplier shall request <i>acceptance</i> before that component can be delivered to ITER. <i>For All VQC.</i>
59	26.1 - Baking	Baking procedures	<input type="checkbox"/>	<input type="checkbox"/>	The supplier shall submit for review and <i>acceptance</i> procedures detailing the method of baking vacuum components. <i>For All VQC.</i>

60	26.7 - Vacuum Conditioning of Carbon Composites	Conditioning (baking) procedures	<input type="checkbox"/>	<input type="checkbox"/>	The supplier shall submit for review and <i>acceptance</i> procedure detailing the method of vacuum conditioning carbon composite components. <i>For All VQC.</i>
-----------	---	----------------------------------	--------------------------	--------------------------	---

#	ITER Vacuum Handbook Section Reference	<i>Acceptance</i>	Proc.	PA	Note
61	28 – Marking of Vacuum Equipment	Chemical etching procedures	<input type="checkbox"/>	<input type="checkbox"/>	The supplier shall submit for review and <i>acceptance</i> details of chemical etching operations to be carried out on vacuum equipment. <i>Applies to VQCI.</i>
62	29 – Packing and Handling of Vacuum Equipment	Backfilling of volumes	<input type="checkbox"/>	<input type="checkbox"/>	Where it is not practical to backfill volumes pumped for leak testing to 0.12 MPa the supplier shall submit for review and <i>acceptance</i> an alternative method. <i>For All VQC.</i>
63	29 – Packing and Handling of Vacuum	Component packaging	<input type="checkbox"/>	<input type="checkbox"/>	Where it is not practical to seal components in polyethylene for shipping (sealed bag filled with dry air) the supplier shall propose for review and <i>acceptance</i> alternative methods of packing. <i>For All VQC.</i>

ITER Vacuum Handbook Appendix 6

Guideline (not under Configuration Control)

6. Requirements for the Supply of Vacuum Windows

6.1. Scope

This appendix is written as a guide for the manufacture and supply of vacuum window assemblies for use on the ITER project.

It is intended that the *suppliers* of vacuum bellows and flexibles should follow the guidance in this appendix to achieve the requirements of the ITER Vacuum Handbook.

The *supplier* is at liberty to utilize other techniques not described in this appendix provided that the components manufactured comply with the requirements of ITER Vacuum Handbook.

“Supply” includes the design, manufacture, testing and delivery of windows as described in the specifications, including the design, manufacture and testing of beryllium windows for use on ITER diagnostic systems.

6.2. Design

ITER IO is responsible for specifying the interface between ITER systems and the window assemblies.

The supplier is responsible for the detailed design of the window assemblies.

Flanges or end fittings will be specified by ITER in accordance with The ITER Vacuum Handbook Appendix 8 and the design of the window assembly must conform to the ITER remote handling requirements as detailed in the ITER Remote Handling Code of Practice.

Window assemblies for use on ITER vacuum vessels forming part of the vacuum containment boundary for VQC1A should be bakeable to 250°C and, to conform to the ITER Vacuum Handbook Section 15, should be of a double window design (either pre- assembled or installed as separate elements) unless permanently installed behind an Ultra High Vacuum (UHV) isolating valve. The interspace between the two windows will be backfilled with a suitable gas (as *accepted* by the ITER Vacuum Responsible Officer) and connected to the Service Vacuum System.

Similarly, window assemblies for use on ITER vacuum vessels forming part of the vacuum containment boundary for VQC2A should be of double construction. However, there is no requirement to operate at elevated temperatures.

For windows transmitting high power (e.g. RF heating systems) the interspace pressure needs to be monitored continuously and suitably interlocked with the power system.

Window assembly interspace volumes are to be manufactured with suitable connections to the Service Vacuum System, as detailed in the ITER Vacuum Handbook Section 8.

Windows used in VQC, 3 & 4 may be of a single window construction.

All joining processes, bonding of the window to the ferrule and brazing or welding of the

metallic components, have to be pre-qualified and production proof samples should be made during the manufacturing process (see Attachment 1).

6.3. Materials

All vacuum facing materials for use in the manufacture of window assemblies should comply with the ITER *accepted* materials list (Appendix 3).

6.3.1. Windows

CVD Diamond, natural crystal quartz, synthetic crystal quartz and sapphire are *accepted* for use in ITER window assemblies forming primary vacuum containment. Beryllium Oxide is *accepted* for use in vacuum windows that form part of the primary vacuum containment after qualification of the window in accordance Section 6.5 of this Appendix. Sodium chloride and other hygroscopic materials are not *accepted* for use in VQC1 & VQC2 systems.

6.3.2. Window (body) Assemblies

All tubes/pipes are to be of seamless construction and comply with the ITER Vacuum Handbook Appendix 11.

In accordance with the ITER Vacuum Handbook, Appendix 8 flanges should be manufactured from forged material and supplied as follows:

Materials selection is to comply with Appendix 3

When there is a vacuum boundary across the grain of thickness <5 mm, the material must be Electro-Slag Remelted (ESR) or Vacuum Arc Remelted (VAR). The use of plate is prohibited. Alternative processes for achieving the required inclusion limits may be *accepted* if successfully validated.

The rate of inclusions in such steels should be checked in accordance with ASTM E-45 Method D (or equivalent) to be within the following inclusion limits:

- Inclusion Type A ≤ 1.0
- Inclusion Type B ≤ 1.0
- Inclusion Type C ≤ 1.0
- Inclusion Type D ≤ 1.5

6.4. Manufacture

Before assembly commences the supplier should submit to ITER for *acceptance* the documents listed in Section 6.10.

Tools used during the manufacture of the window assemblies must not contaminate the vacuum surfaces. Cutting fluids need be *accepted* before use and will be water based, oil free, non-halogenated, sulphur and phosphorus free. Those listed in Appendix 4 are *accepted* and, if chosen, should be specified in the quality plan and agreed in advance.

Cleaning operations need to be performed to an *accepted* procedure in accordance with the ITER Vacuum Handbook Appendix 13. The use of chlorine and other halogen containing fluids (e.g. trichloroethylene) is strictly forbidden.

All assemblies must be individually identified, packaged and shipped to the ITER site in accordance with Section 22 of the ITER Vacuum Handbook.

6.4.1. *Welding of Window Assemblies*

Prior to manufacture the supplier should submit a weld plan in accordance with the ITER Vacuum Handbook Attachment 1. The weld plan is a drawing which cross references each welded joint to a supporting Weld Procedure Specification (WPS).

Welding procedures and the Procedure Qualification Records should be qualified in accordance with Attachment 1

Where practical, all welds shall be full penetration butt welds unless otherwise *accepted*.

100 % visual examination of welds should be carried out in accordance with the ITER Vacuum Handbook Attachment 1

Butt welds are to be 100 % radiographed in accordance with the ITER Vacuum Handbook Attachment 1

Where radiography is not feasible, production proof samples must be performed in accordance with the ITER Vacuum Handbook Attachment 1

Dye-Penetrant examination of production welds is only permitted in accordance with the ITER Vacuum Handbook.

6.4.2. *Bonding of Windows*

All windows should be bonded into metal ferrules.

6.4.2.1. VQC 1

Windows should be bonded into the window assemblies by aluminium bonding. Other bonding methods may be used with the advance agreement of the ITER Responsible Officer after acceptance of the method.

6.4.2.2. VQC 2

In addition to aluminum bonding, Silver-Lead-Tin Eutectic may be used for windows for use on the outer cryostat boundary.

6.5. **Qualification of Windows (type testing)**

Prior to the manufacture of window assemblies the supplier must qualify the window design. The supplier should submit for acceptance a qualification plan (as part of the quality plan) detailing the tests to be performed on window assemblies. After the completion of all manufacturing processes the window assemblies should undergo the following qualification tests.

1. Pressure test¹
2. Mechanical shock testing
3. Thermal shock test
4. Helium leak test
5. High power RF transmission (where applicable)

¹ The pressure test should include a rapid vent "type test" in which the window is mounted in a small evacuated vessel which is then vented rapidly (simulating survival of a Vacuum Vessel loss of vacuum event). In each case the method of testing should be *accepted* before manufacture shall commence.

6. Voltage stand-off (including Paschen breakdown where applicable)

6.5.1. Pressure testing

Prior to leak testing it must be demonstrated that the window assemblies can withstand, and remain unaltered by, a 0.2 MPa pressure differential in either direction. Proof tests to 0.3 MPa are required to qualify the window assemblies.

6.5.2. Mechanical shock

Type testing of the window bonded elements must show no failure at 15 g acceleration for 1000 cycles.

6.5.3. Thermal Shock

Type testing of the window bonded elements must exhibit no change in helium leak rate when sprayed with water at 100°C while at the window normal operating temperature.

6.5.4. Leak Testing

The supplier should perform leak testing of the window assemblies in accordance with the ITER Vacuum Handbook Appendix 12.

Window assemblies for use on VQC1 systems should be baked and hot leak tested at 250 °C as follows:

1. Global leak test of the window assembly
2. Leak test of the water cooling circuits (if applicable)
3. Leak test of the window interspace (both to vacuum and to atmosphere)

The leak test procedure should include three operating cycles of the window assembly at each test temperature before leak testing.

The procedure for baking windows should be in accordance with the ITER Vacuum Handbook Appendix 15 and should be submitted for acceptance before baking operations start.

Immediately after bake-out, these tests should be repeated at room temperature.

In both cases the acceptance leak rate shall be met with the background reading on the leak detector being at least one order of magnitude below the acceptance leak rate without electronic correction. Leak rates for window assemblies for VQC1 (including the window interspace) should not exceed 1×10^{-10} Pam³s⁻¹ at 250°C

Window assemblies for use on VQC 2 systems should be subject to the same tests as VQC 1 but with the requirement for temperature cycling waived. Leak rates for window assemblies for VQC2 should not exceed 1×10^{-10} Pam³s⁻¹ at ambient temperature.

Acceptance criteria for window assemblies is summarized in Table 6-1.

	VQC 1 ¹	VQC 2 ²
Max global leak rate	$1 \times 10^{-10} \text{ Pam}^3\text{s}^{-1}$	$1 \times 10^{-10} \text{ Pam}^3\text{s}^{-1}$
Max leak rate from / to window interspace	$1 \times 10^{-10} \text{ Pam}^3\text{s}^{-1}$	$1 \times 10^{-10} \text{ Pam}^3\text{s}^{-1}$ (if applicable)
Max cooling channel leak rate	$1 \times 10^{-10} \text{ Pam}^3\text{s}^{-1}$	$1 \times 10^{-10} \text{ Pam}^3\text{s}^{-1}$ (if applicable)

Table 6-1: Window assembly Leak Rates.

1. Acceptance criteria at 250 °C
2. Acceptance criteria at ambient

6.5.5. High Power RF Transmission

On windows designed for the transmission of high power RF it must be demonstrated that the vacuum properties of the window remain unaltered when high power RF is applied. The supplier shall submit for acceptance a test plan detailing the method and type of transmission tests to be performed in the qualification of the windows assemblies.

6.5.6. Voltage Stand-off

The supplier must demonstrate that windows required to stand off high voltage can do so with no degradation of the vacuum performance of the windows. It must also be demonstrated that the window assemblies are suitable protected from Paschen discharges (if applicable). The supplier shall submit for acceptance a test plan detailing the method and type of tests to be performed in the qualification of the window assemblies.

6.6. Testing and Inspection of Window Assemblies

Prior to the manufacture of window assemblies the supplier should provide for acceptance a test plan and test procedures detailing the tests to be performed on window assemblies before delivery to the ITER site. After the completion of all manufacturing processes the window assemblies should undergo a vacuum baking cycle to the operating temperature and a helium leak test according to 6.6.1 below.

6.6.1. Leak testing

Prior to delivery to the ITER site, windows should be subject to helium leak testing in accordance with Section 6.5.4. Windows will be subject to acceptance helium leak testing on delivery to the ITER site.

6.7. Marking

Each window assembly should be individually marked with a unique identification which is traceable to the window assembly document package. The use of dyes, paints, pens and other such markers that transfer marking material into any window assembly surface should not be used for the marking of window assemblies. Scribing with a clean sharp point and vibro-etching are acceptable marking processes. Chemical etching is also acceptable, but not for use on for VQC1 vacuum facing surfaces.

6.8. Packaging & Delivery

The packaging and delivery of window assemblies to the ITER site should be in accordance with the ITER Vacuum Handbook.

Where practical, window assemblies should be entirely enclosed in heat sealed polyethylene and backfilled with a suitable dry gas. Nitrogen is preferred but other gasses may be permitted with prior *acceptance*. All window assemblies shall be shipped dry internally and externally irrespective of final acceptance testing at the manufacturer's site.

The use of adhesive tape for the protection and packaging of components must be limited to prevent the risk of contamination from the tape. In particular tape used on austenitic stainless steel should meet leachable chloride and fluoride limits of 15 ppm and 10 ppm, respectively. Where used, tape must be fully removable without residue, using isopropyl alcohol or acetone as the solvent if necessary.

All window assemblies should be transported in rigid packing cases or containers which are lined with waterproof material. Components must be packed with adequate protection from thermal and mechanical stresses (particularly shock loads resulting from dropping and mal-handling) which may adversely affect the operation of the window. All packing case joints should be sealed and cases marked with individual window specific identification. Handling instructions should also be clearly marked on the outer packaging. Chemical or radiological hazards, etc., should be identified on the packaging. All packaging markings will be in English and French and include the Vacuum Classification of the component(s).

6.9. Incoming inspection at the ITER Site

In addition to the inspection detailed in this Appendix, window assemblies will be subject to an incoming inspection on delivery to the ITER site. This will include, as a minimum, dimensional inspection for compliance with the technical specification and helium leak testing in accordance with the ITER Vacuum Handbook Appendix 12.

6.10. Documentation

The following documents shall be *accepted* before pre-manufacture activities commence:

- ▶ Weld Plan
- ▶ Quality Plan (including test plan /schedule)
- ▶ Welding Procedures and Welder Qualifications
- ▶ Dimensional Drawings
- ▶ Qualification test plan

The following documents shall be *accepted* before manufacture commences:

- ▶ Type testing report

On completion of manufacturing, two sets of the following documents should be supplied as data books:

- ▶ Signed-off Quality Plan
- ▶ Welding Procedures and Welder Qualifications
- ▶ Radiographic Reports (if applicable)
- ▶ Production Proof Sample Reports (if applicable)
- ▶ Material Certificates, traceable to assemblies, in accordance with EN 10204 2.2 ,3.1 or 3.2
- ▶ Dimensional drawings identifying welds
- ▶ Type testing report (s)
- ▶ Dimensional Inspection Report

ITER Vacuum Handbook Appendix 7

Guideline (not under Configuration Control)

7. Requirements for the Supply and Modification of All-Metal Ultra High Vacuum Valves

This Appendix is written as a guide for the manufacture and supply and modification of all metal ultra high vacuum vacuum valves for use on ITER vacuum systems. It is intended that the *suppliers* of such vacuum valves should follow the guidance in this Appendix to achieve the requirements of the ITER Vacuum Handbook.

The *supplier* is at liberty to utilize other techniques not described in this Appendix provided that the components manufactured comply with the requirements of the ITER Vacuum Handbook.

“Supply” includes the design, manufacture, testing and delivery of bellows and flexibles as described in the specifications.

7.1. Design

ITER is responsible for specifying the interface between ITER systems and the valves. The supplier is responsible for the detailed design of the valves including any modifications as specified by ITER.

Flanges or end fittings shall be specified by ITER and supplied in accordance with the ITER Vacuum Handbook Appendix 8.

Valves used for ITER vacuum vessel isolation (VQC1A) should be bakeable to 250°C in the open and closed positions and, in accordance with the requirements of the ITER Vacuum Handbook, should be of double bellowed design. VQC 1 valves should be able to operate at 250°C and be of all metal construction (seal, body etc). Demountable valves for use on VQC 1A should utilize a metal double seal arrangement conforming with the requirements of the ITER Vacuum Handbook Appendix 8.

VQC 2 & 3 valves are not required to operate at elevated temperature but must be of all metal vacuum containment.

There is no requirement for VQC 4 valves to be bakeable or of all metal design.

Pneumatic seals and electrical components for valves used in systems with classification VQC1 should withstand a total radiation integrated dose of 10⁸ Gray (TDB)

Where valves require to be remotely handled as a unit rather than as part of an integrated remotely handled assembly, they should be designed in accordance with the requirements ITER Remote Handling Code of Practice.

The design life of valves for use on ITER should be such as to limit intervention for replacement or repair during the operational phase of the ITER Project. Typically valves for ITER vacuum vessel isolation should be designed to operate for a minimum of 5000 cycles without the requirement for intervention. This requirement applies to all torus isolation valves with the exception of valve sizes larger than DN1500 mm (e.g. Neutral Beam isolation

valves).

7.2. Additional requirements for the supply of standard valves with modified ends

The requirements of the ITER Vacuum Handbook and this Appendix should also apply to valves with modified ends. In addition, the following requirements will apply to the modified parts only.

7.2.1. Materials

7.2.1.1. General

All vacuum facing materials for use in the manufacture of bellows should comply with the requirements of the ITER Vacuum Handbook. In particular materials should be taken from the ITER Vacuum *accepted* materials list (ITER Vacuum Handbook Appendix 3) and be consistent with the outgassing requirements of the ITER Vacuum Handbook.

7.2.1.2. Metallic Machined Components and Fittings

All VQC 1A components which are machined from steel, austenitic steel or superalloys and which are of final thickness less than 5 mm, should be made from cross-forged material which is Electro-Slag Remelted (ESR) or Vacuum Arc Remelted (VAR). The use of plate is prohibited. Alternative processes for achieving the required inclusion limits may be *accepted* if successfully validated.

The rate of inclusions in such steels should be checked in accordance with ASTM E- 45 Method D (or equivalent) to be within the following inclusion limits:

Inclusion Type A ≤ 1.0

Inclusion Type B ≤ 1.0

Inclusion Type C ≤ 1.0

Inclusion Type D ≤ 1.5

Both halves of demountable flanges using metal seals are normally to be manufactured from cross or upset forged material. Stainless steel knife-edge sealed flanges of any thickness for all vacuum classifications should be manufactured from cross-forged ESR grade material blanks. All VQC 1A and 2A demountable vacuum flanges should be made from cross-forged or upset forged material.

7.2.2. Fabrication

Before assembly commences the supplier shall submit to ITER for *acceptance* the documents listed in Section 7.7

Tools used during the manufacture of the valves must not contaminate the vacuum surfaces. Cutting fluids need be *accepted* before use and will be water based, oil free, non-halogenated, sulphur and phosphorus free. Those listed in Appendix 4 are *accepted* and, if chosen, should be specified in the quality plan and agreed in advance.

Cleaning operations need to be performed to a procedure *accepted* by ITER in accordance with the ITER Vacuum Handbook Appendix 13. The use of chlorine and other halogen containing fluids (e.g. trichloroethylene) is strictly forbidden.

All assemblies must be individually identified, packaged and shipped to the ITER site in accordance with Section 22 of the ITER Vacuum Handbook.

7.2.2.1. Welding

The qualification, production and testing of welds should be in accordance with the ITER Vacuum Handbook Attachment 1.

In particular:

1. Before fabrication can commence the *supplier* should prepare for *acceptance* a weld plan. The weld plan is a drawing which cross references each welded joint to a supporting Weld Procedure Specification (WPS).
2. All welds should be qualified prior to manufacture.
3. 100% visual examination of production welds should be performed.
4. 100% volumetric examination of production welds should be performed, unless a method of pre-production proof sampling is *accepted*.
5. Dye-Penetrant examination of production welds is only permitted in accordance with the ITER Vacuum Handbook.

7.3. Leak Testing

Prior to shipping all valves should be subject to an acceptance vacuum leak test. Detailed leak testing procedures in accordance with the ITER Vacuum Handbook Appendix 12 should be submitted for *acceptance*.

Helium leak testing should include the following steps:

Valves for use on VQC1 systems should be baked and hot leak tested at 250°C as follows:

1. Valve body
2. Across the valve seat.
3. Valve actuator bellows.
4. Internal pressure element.
5. Double bellows interspace.
6. VQC 1A double seal interspace.

Immediately after bake-out, the same tests must be repeated at ambient temperature. In both cases the acceptance leak rate shall be met with the background reading on the leak detector being at least one order of magnitude below the acceptance leak rate without electronic correction. In each case, the leak test procedure should include three operating cycles of the valve at each test temperature before leak testing. Leak rates for valve assemblies (including double bellows interspace), and across the valve seat, should not exceed $1 \times 10^{-10} \text{ Pam}^3\text{s}^{-1}$ at 250 °C

Valves for use on VQC 2 systems are subject to the same tests as VQC 1 with the requirement for temperature cycling waived. Leak rates for valve assemblies (including double bellows interspace), and across the valve seat, should not exceed $1 \times 10^{-10} \text{ Pam}^3\text{s}^{-1}$.

It is expected that valves for use on VQC 3 & 4 systems will be delivered to ITER as proprietary items and hence be delivered with a manufacturer's certificate of conformity confirming leak tightness. In this case, proprietary valves may be subjected only to an ambient temperature acceptance test at the ITER site prior to installation. Leak rates for

proprietary valve assemblies (including double bellows interspace), and across the valve seat, should not exceed $1 \times 10^{-10} \text{ Pam}^3\text{s}^{-1}$.

All leak tests and test facilities may be the subject of inspection by the ITER Vacuum Responsible Officer or nominated representative and hence the ITER Vacuum Responsible Officer must be notified as of the final timing of tests a minimum of 4 weeks prior to the tests commencing.

7.4. Marking

Each valve should be individually marked with a unique identification which is traceable to the valve document package. The use of dyes, paints, pens and other such markers that transfer marking material into any window assembly surface must not be used for the marking of window assemblies. Scribing with a clean sharp point and vibro-etching are acceptable marking processes.

Each valve shall be marked with an arrow clearly identifying the seal face direction of the valve.

7.5. Documentation

Valve data sheets are to be supplied for all valves. A suppliers' certificate of conformity is required confirming that the valves supplied conform to the valve data sheet as revised and accepted by ITER. Leak test reports and / or Certificates of Conformity must be supplied in accordance with the relevant requirements of the ITER Vacuum Handbook.

7.6. Packaging & Delivery

The packaging and delivery of valves to the ITER site should be in accordance with ITER Vacuum Handbook.

Valves should be entirely enclosed in heat sealed polyethylene and backfilled with a suitable dry gas. Nitrogen is preferred but other gasses may be *accepted*. All valve assemblies must be shipped dry internally and externally irrespective of final acceptance testing at the manufacturer's site.

The use of adhesive tape for the protection and packaging of components must be limited to prevent the risk of contamination from the tape. In particular tape used on austenitic stainless steel should meet leachable chloride and fluoride limits of 15 ppm and 10 ppm, respectively. Where used, tape should be fully removable without residue, using isopropyl alcohol or acetone as the solvent if necessary.

All valve assemblies should be transported in rigid packing cases or containers which are lined with waterproof material. Components should be packed with adequate protection from thermal and mechanical stresses which may adversely affect the operation of the valves. All packing case joints should be sealed and cases marked with individual valve specific identification. Handling instructions should also be clearly marked on the outer packaging. Any chemical or radiological hazards, etc., must be identified on the packaging. All packaging markings should be in English and French and include the VQC of the valve.

7.6.1. *Incoming inspection at ITER Site*

In addition to the inspection detailed in this Appendix, window assemblies will be subject to an incoming inspection on delivery to the ITER site. This will include, as a minimum, dimensional inspection for compliance with the technical specification and helium leak testing in accordance with the ITER Vacuum Handbook Appendix 12.

7.7. Documentation

Valve data sheets should be supplied for all valves.

A suppliers' certificate of conformity is required confirming that the valves supplied conform to the valve data sheet as revised and *accepted* by ITER.

Leak test reports and / or Certificates of Conformity must be supplied in accordance with the relevant requirements of the ITER Vacuum Handbook.

The following documents should be accepted before pre-manufacture activities commence:

- Weld Plan
- Quality Plan (including test plan /schedule)
- Welding Procedures and Welder Qualifications
- Dimensional Drawings

On completion of manufacturing, two sets of the following documents should be supplied as data books:

- Signed-off Quality Plan
- Welding Procedures and Welder Qualifications
- Radiographic Reports (if applicable)
- Production Proof Sample Reports (if applicable)
- Material Certificates, traceable to assemblies, in accordance with EN 10204 2.2, 3.1 or 3.2
- Dimensional drawings identifying welds
- Test reports
- Dimensional inspection report.

ITER Vacuum Handbook Appendix 8

Guideline (not under Configuration Control)

8. Flanges demountable

8.1. Terms and acronyms

The terms and acronyms detailed in Table 1 are used throughout this document.

Term / Acronym	Contextual meaning
<i>Accepted</i>	Accepted by ITER Vacuum RO through submission for Request for <i>Acceptance</i> [1].
COTS	Commercial Off The Shelf (item listed in a suppliers catalogue)
Flange set	Demountable vacuum joint and gasket seal
Flange	1 half of demountable joint
Gasket or Seal	Replaceable piece which forms the vacuum containment. No distinction of these two terms is made in this appendix.
Mounting	Joining of a flange pair & seal to make the flange set.
Rectangular Type Flange	A generally rectangular or non-circular flange using a shaped seal.
RO	Responsible Officer

Table 1: Terms and acronyms.

8.2. Scope

The scope of this appendix is to define the vacuum demountable flange sets *accepted* for use on the ITER Vacuum Systems. Flange sets (demountable vacuum joint and specified seal arrangements) listed herein may be used, as specified, without further approval. Demountable vacuum joints not detailed in this appendix shall only be utilized after *acceptance* by the ITER vacuum RO. *Acceptance* of a demountable vacuum joint and seal combination not listed herein will require qualification of the flange set. Qualification of a flange set shall be performed to an *accepted* procedure.

In the case of the ITER style flanges the information included here shall be considered final. The flanges are qualified, see [2] for the Qualification Summary Report. Finalized drawings and seal part numbers are given in Table 9 and Table 4 respectively. The manufacture of these flanges and their primary bolting is to be made in accordance with [3] and [4] taking in to account the design code used for the equipment that they are fitted to. Non circular or

Rectangular flanges are accepted as an alternative to circular flanges in cases where geometric constraints justify their use. These flanges are specific and no standard exists to cover them. In the case of their need the seal manufacture should be consulted early in design process. The strategic agreement [5] provides a route for flange design.

8.3. Accepted Flange Set Combinations

8.3.1. Standard Flange Set DN (Nominal Diameter)

The flange set DN nominal diameters used shall comply with Table 2.

	DN10 DN16	DN25	DN40	DN50	DN63	DN100	DN160	DN200	DN250	DN300
CF*	✓	✓	✓	✓	✓	✓	✓	✓	✓	
ISO-KF	✓	✓	✓	✓	✓					
ISO-K					✓	✓	✓	✓	✓	✓
VCR ¹	✓	✓								
ITER Style					✓ (DN65)	✓	✓ (DN150)	✓	✓	✓
✓ Accepted for use										
* CF sizes shall be in accordance with ISO 3669-2:2007 [6], ¹ VCR from 6 to 25 mm (1/4 to 1 inch)										

Table 2: Flange Size.

8.3.2. Type of Flange Set

The type of flange set and seal combinations shall comply with Table 3.

Vacuum Classification [7] (VQC)	Behind an Accepted Isolating Valve (Y/N) ¹	Flange Set	Double Seal Required?	Range of size (DN)	1 st (Vacuum) Seal Material	2 nd (Atmosphere) Seal Material
1	No	ITER Style	Yes	63 - 300	Metallic – Silver jacketed Helicoflex Table 4 [5]	
	Yes	ITER Style	Recommended	63 - 300	Metallic – Silver jacketed Helicoflex Table 4 [5]	
	Yes	ISO-CF	No	16 - 250 ²	Silver coated copper gasket	N/A
	Yes	ISO-K	No	63 – 100	Aluminium edge type Table 6 [8]	N/A
	Yes	ISO-KF	No	16 - 63	Aluminium edge type Table 6 [8]	N/A
	Yes	VCR	No	¼ -1 inch	Silver coated gasket in carrier Table 5 [9]	N/A
2	N/A	ITER Style	Yes	63 - 300	Metallic – Silver jacketed Helicoflex Table 4 [5]	
	N/A	ITER Style	Yes	63 - 300	Metallic – Silver jacketed Helicoflex [10]	Seal material from Table 7
	N/A	ISO-CF	No	16 - 250 ²	Silver coated copper gasket	N/A
	N/A	ISO-K	No	63 – 100	Aluminium edge type Table 6 [8]	N/A
	N/A	ISO-KF	No	16 - 63	Aluminium edge type Table 6 [8]	N/A
	N/A	VCR	No	¼ -1 inch	Silver coated gasket in carrier Table 5 [9]	N/A

Vacuum Classification [7] (VQC)	Behind an Accepted Isolating Valve (Y/N) ¹	Flange Set	Double Seal Required?	Range of size (DN)	1 st (Vacuum) Seal Material	2 nd (Atmosphere) Seal Material
3	N/A	ITER Style	Yes	63 - 300	Metallic – Silver jacketed Helicoflex [10]	N/A
	N/A	ITER Style	Yes	63 - 300	Metallic – Silver jacketed Helicoflex [10]	N/A
	N/A	ISO-CF	No	16 - 250 ²	Silver coated copper gasket	N/A
	N/A	ISO-K	No	63 – 100	Aluminium edge type Table 6	N/A
	N/A	ISO-KF	No	16 - 63	Aluminium edge type Table 6	N/A
	N/A	VCR	No	¼ - 1 inch	Silver coated gasket in carrier Table 5 [9]	N/A
4	Yes	ISO-CF	No	16 - 250 ²	Silver coated copper gasket	N/A
	Yes	ISO-K	No	63 – 100	Aluminium edge type Table 6	N/A
	Yes	ISO-KF	No	16 - 63	Aluminium edge type Table 6	N/A
	Yes	VCR	No	¼ - 1 inch	Silver coated gasket in carrier Table 5 [9]	N/A
	N/A	ISO-K	No	63 - 400	Table 7	N/A
	N/A	ISO-KF	No	16 - 63	Table 7	N/A
¹ Isolates system from main VV						
² See section 8.4.1 for CF flange restrictions						

Table 3 Accepted flange set and seal combination.

8.3.3. *Flange Mounting / Demounting*

Design of Vacuum Flanged Systems

The design of VQC 1 systems utilizing flanges shall be such that the system, or components of the system, can be removed from the area of service through the demounting of ITER style flange set, see Table 3.

Flange Mounting

Flange shall be mounted and tested according to the procedures given in [11].

Vacuum Testing

100 % of vacuum flange sets shall be helium leak tested to ensure the vacuum performance of the flange set is compliant with its VQC.

Where a system or component of a system has been removed from the area of service VQC 1 flange other than ITER style shall be helium leak tested prior to the system or component installation in the area of service.

ITER style flange sets shall be helium leak tested on mounting.

Flange Demounting

Where there is a requirement to breach a VQC 1 boundary through the demounting of an accepted vacuum flange, Table 3, the breach shall only be made at an ITER style flange set.

It is prohibited to demount VQC 1 flange sets other than ITER style in the area of service (e.g. in the port cell). The system, or components of the system, shall be transported to a suitably contamination controlled area (e.g. the hot cell) prior to the demounting of a VQC 1 flange set other than ITER style.

8.3.4. *Seal Material Type*

Metallic Seal Combinations

ITER Style Flanges

ITER style flanges have been qualified with specific seals. The manufacturer's part number of seals to be used with ITER style flanges is given in Table 4. These shall be ordered to the requirements of technical specification [5] to ensure their qualification. The use of seals other than those with part numbers compliant with the manufacturing drawings is prohibited unless *accepted* by the ITER Vacuum RO.

Seal Description & Flange Size	Manufacture's Drawing (SMDD Reference)	TECHNETICS Part number Reference
HELICOFLEX HND 229 - DN65	111-0081957 REP 01 https://user.iter.org/?uid=4JDTQJ	211439
HELICOFLEX HND 229 - DN100	111-0081957 REP 02 https://user.iter.org/?uid=4JDTQJ	224803
HELICOFLEX HND 229 - DN150	111-0081957 REP 03 https://user.iter.org/?uid=4JDTQJ	211440
HELICOFLEX HND 229 - DN200	111-0081957 REP 04 https://user.iter.org/?uid=4JDTQJ	224804
HELICOFLEX HND 229 - DN250	111-0081957 REP 05 https://user.iter.org/?uid=4JDTQJ	224805
HELICOFLEX HND 229 - DN300	111-0081957 REP 06 https://user.iter.org/?uid=4JDTQJ	224806
HELICOFLEX HND 229 – DN500	111-0168156 https://user.iter.org/?uid=8SXRNW	234614

Table 4 Authorized ITER Style Flange Seals.

VCR

VCR® is a registered trademark of Swagelok. VCR flange sets shall utilise silver coated stainless steel gaskets with the Swagelok part numbers as listed in Table 5.

VCR (inch)	Product description (part number) [9]
1/4	316 SS VCR Face Seal Fitting, 1/4 in. Silver-Plated Gasket Retainer (SS-4-VCR-2-GR)
1/2	316 SS VCR Face Seal Fitting, 1/2 in. Silver-Plated Gasket Retainer Assembly (SS-8-VCR-2-GR)
3/4	316 SS VCR Face Seal Fitting, 3/4 in. Silver-Plated Gasket Retainer (SS-12-VCR-2-GR)
1	316 SS VCR Face Seal Fitting, 1 in. Silver-Plated Gasket Retainer (SS-16-VCR-2-GR)

Table 5 VCR gasket product description and manufacturer's part number.

CF type flange sets shall utilise silver coated high-purity, oxygen-free (OFHC) copper gaskets.

Aluminium Edge Type

Aluminium edge type seals shall be utilised for ISO – K and ISO - KF flange sets.

For reference a manufacturer's part number of aluminium edge type gasket seals are provided in Table 6.

Nominal Diameter (DN)	Manufacturer's Part Number [8]	
	ISO - K	ISO - KF
1 6		34.016001.142.116-iz1
2 5		34.016001.142.125-iz1
4 0		34.040001.142.140-iz1
5 0		34.050001.142.150-iz1
6 3	34.063001.342.106	34.063001.142.163-iz1
8 0	34.080001.342.108	
1 0 0	34.100001.342.110	

Table 6 EVAC Al edge type gasket seal part numbers.

Non-metallic Seals

Non-metal seal gasket material shall be chosen from Table 7. The seal gasket material chosen shall be compatible with the area of service. The radiation environment that the seal shall operate is defined in the ITER Nuclear Safety Room Book [12].

Material	Temperature limit (°C)	Maximum allowable accumulated lifetime dose 1 MeV equivalent (Gray)
Viton	150	1×10^3
EPDM (Ethylene- propylene)	120	5×10^5
Nitrile rubber (Buna – N)	80	1×10^4

Table 7 Seal material temperature and radiation limits.

8.3.5. Clamping Arrangement

The flange set clamping arrangement utilised shall comply with Table 8.

Flange set	Clamping Arrangement	Flange Option
ITER Style	Bolt ring	Fixed, rotatable
ConFlat	Bolt arrangement	Fixed, rotatable
ISO - KF	Chain clamp, ISO-K cold steel double clamp.	N/A
ISO - K		

Table 8 Flange clamping arrangement.

8.4. Flange Set Manufacture

8.4.1. COTS Flange Sets

CF, VCR ISO-K and ISO-KF flange sets are commercially available items readily available in all parties' countries. It is recommended that these items be purchased from companies supplying vacuum equipment as part of their core business. The use of flange sets which are not purchased from a company supplying vacuum equipment as part of its core business shall only be by prior *Acceptance*.

To ensure compatibility between flanges (knife edge dimensions, bolt circle and number, etc.) manufacturers of CF larger than DN160 in size shall be *accepted* by the ITER Vacuum RO.

8.4.2. ITER Style Flange Set

ITER style flanges shall be manufactured according to the requirements of this Appendix and following the requirements of the ITER Vacuum Handbook [7] and the respective technical specifications [3] & [4].

Manufacturing Drawings

ITER Style flanges shall be manufactured in accordance with the drawings listed in Table 9.

Nominal Diameter	SMDD drawing Folder ¹
DN65	https://user.iter.org/?uid=2C5DKZ
DN100	https://user.iter.org/?uid=2JGYRT
DN150	https://user.iter.org/?uid=24S93M
DN200	https://user.iter.org/?uid=2JH5JK
DN250	https://user.iter.org/?uid=2JHULA
DN300	https://user.iter.org/?uid=2JHVRY
DN500	https://user.iter.org/?uid=2ASVVP
¹ The parent folder for all ITER style flange assembly drawings are found this SMDD folder https://user.iter.org/?uid=YUR2QY .	

Table 9 ITER Style flange drawing reference.

ITER Style Flange Circular Seal Surface Requirements

The manufacturing drawings detail the surface finish requirement. For the avoidance of any doubt these are:

1. The direction of the surface finish lay shall be circular and have a turned finish.
2. The surface roughness of the seal surface shall be between 1.6µm Ra and 3.2µm Ra.
3. The spacing parameter of the seal surface shall have a value of $RS_m \leq 0.15\text{mm}$ Maximum.
4. The seal surface shall be free of any cross scratches.
5. The surface finish shall be specified on drawings using the symbols from ISO 1302.
6. After finishing the seal surface shall be protected in all further operations.
7. In the case that there are holes to be made in the sealing surface either for attachment or venting ports these shall be made before the final finishing of the seal surface to prevent any subsequent damage.

8.4.3. Rectangular or Shaped Type Flange sets

These special flange sets are commonly known either as Shaped, Rectangular or Race Track types and need particular attention to their design to ensure that they can meet the leak rate requirements of the VQC specified. The detail of their design is bespoke as no standard covers them.

Rectangular or Shaped Seal Surface Requirements - Metallic Seals

In the case that a metallic sealing of the spring energized type is used on a Shaped, Rectangular or RaceTrack flange then the Surface finishing requirements shall be:

1. The direction of the surface finish lay shall be parallel at all times to the axis of the seal torus.
2. The surface roughness of the seal surface shall be greater than 0.4µm Ra and less than

- 1 μ m Ra. The target value shall be 0.8 μ m Ra.
3. The seal surface shall be free of any cross scratches.
 4. The flatness tolerance of the seal surface along the torus axis shall be $< 0.4/1000$.
 5. The flatness tolerance of the seal surface across the torus axis shall be $< 0.5/100$.
 6. The surface finish shall extend up to an additional 5mm each side of the nominal seal torus location to allow for correct landing of the seal on the required surface.
 7. The surface finish shall be specified on drawings using the symbols from ISO 1302.
 8. After finishing the seal surface shall be protected in all further operations.
 9. In the case that there are holes in the sealing surface either for attachment or venting ports these shall be made before the final finishing of the seal surface to prevent any subsequent damage.

These are to be expressed on all drawings thus.

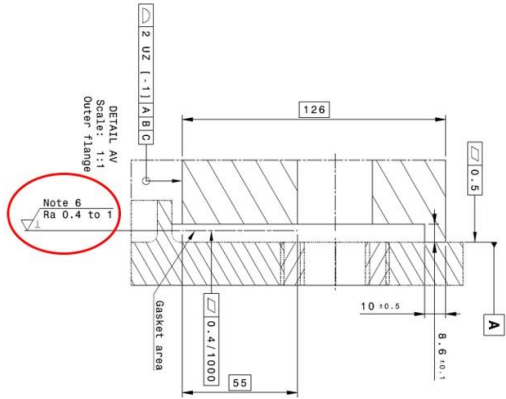
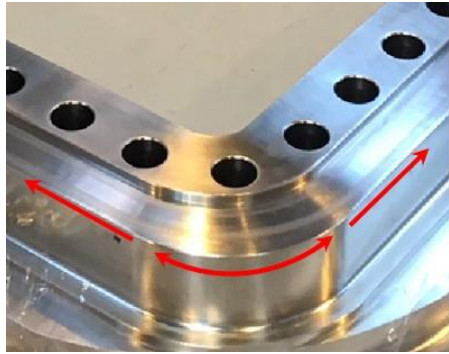
Requirement	Clarifying notes
<p>5. The surface finish lay, as defined by ISO 1302:2002, shall be parallel to the axis of the seal</p> <p>Note 6 : The target value is Ra 0.8 μm</p>  <p>Adapted from Sheet 15 of IO Drawing 050687 ---</p>	<p>ISO 1302</p> <p>Particular attention shall be made to the use of these symbols,</p> <p style="text-align: center;">= , ⊥</p> <p>when defining the lay of the surface finish to ensure the surface finish lay is correctly oriented to the surface and direction of the seal torus.</p> <p>Whenever possible the appropriate symbol shall be applied in two complementary section views to remove any ambiguity on the requirement in the corners of the flange, i.e. the need is for a continuous and smooth radial transition from one straight side to the next straight side, lay direction is show in red in this example.</p>
<p>c 0.4/1000</p>	 <p>Flatness Tolerance of the sealing surface along the torus axis</p>
<p>c 0.5/100</p>	<p>Flatness Tolerance of the sealing surface across the torus axis.</p>
<p>Tolerance of the seal rebate depth - this is specific to the seal torus diameter and required VQC needed</p>	

Rectangular or Shaped Seal Surface Requirements - Elastomer Seals

When using elastomer sealing in place of metallic sealing the same parameters shall be used.

8.5. References

- [1] Request for Acceptance (ITER_D_9AY4HD).
- [2] Qualification Synthesis Report PBS-31 ITER Style Flanges (ITER_D_YPSRU8).
- [3] ITER Style Flange Manufacturing Technical Specification (ITER_D_RSL7WD).
- [4] ITER Style Flange Primary Bolts Manufacturing Technical Specification (ITER_D_RT8BGK).
- [5] Technical Specification strategic agreement of the supply of Spring Energised Metallic Seals for ITER vacuum systems (ITER_D_2LKJ2E).
- [6] ISO/TS 3669-2 Vacuum technology - Bakable flanges: 2007.
- [7] ITER Vacuum Handbook (ITER_D_2EZ9UM v2.5).
- [8] “EVAC,” [Online]. Available: <https://evacvacuum.com/>. [Accessed 14 Nov 2022].
- [9] “VCR® Metal Gasket Face Seal Fittings — Nuts, Gaskets, and Accessories,” [Online]. Available: <https://products.swagelok.com/en/all-products/fittings/vcr-metal-gasket-face-seal-fittings/nuts-gaskets-accessories/c/120?clp=true>. [Accessed 14 Nov 2022].
- [10] “HELICOFLEX® RESILIENT METAL SEAL,” [Online]. Available: <https://technetics.com/products/helicoflex-metal-resilient-seal/>. [Accessed 14 Nov 2022].
- [11] Technical Specification Vacuum Flange Make-up (ITER_D_T6V3EJ).
- [12] Nuclear Safety Roombook, (ITER_D_KF63PB).

ITER Vacuum Handbook Appendix 9

Baseline Report (not under Configuration Control)

9. Guide to the Supply of Double Wall Vacuum Bellows

9.1. Scope

This Appendix is written as a guide for the manufacture and supply of vacuum bellows and flexibles for use on ITER vacuum systems. It is intended that the *suppliers* of vacuum bellows and flexibles should follow the guidance in this Appendix to achieve the requirements of the ITER Vacuum Handbook.

The *supplier* is at liberty to utilize other techniques not described in this Appendix provided that the components manufactured comply with the requirements of the ITER Vacuum Handbook.

“Supply” includes the design, manufacture, testing and delivery of bellows and flexibles as described in the specifications.

9.2. General

Bellows are considered as inherently vulnerable components due to their method of construction and because they are designed to facilitate movement.

Circular bellows are to be designed to the Expansion Joint Manufacturers Association (EJMA) code or to another *accepted* design code. Where design codes do not apply, design shall be by analysis and proven by testing.

Care shall be taken to ensure that the operational loading parameters are fully considered including all design loads and combinations. Precautions need to be taken against rupture and other failure modes where there is a pressure difference in either direction between the inner and outer surfaces of the unit.

In all test situations and after installation, the bellows should be protected against all abnormal load conditions.

9.3. Design of bellows

All bellows for use on VQC 1 and 2 systems should be of double wall construction unless they are accessible for maintenance and fitted behind an *accepted*, interlocked, isolating valve. For VQC 1A bellows separating torus vacuum from air, double wall bellows are a mandatory safety design requirement as specified in the ITER Vacuum Handbook. For VQC 2A where regular and significant movement is to be compensated by a bellows that is not required to be double walled by safety rules, the use of double wall bellows is to be determined by considerations of reliability, maintainability, maintainability and ALARA. Bellows which are of edge-welded construction shall be *accepted* provided that they comply with the ITER Vacuum Handbook Section 7.1.

The interspace between the two walls of the bellows assembly will normally be filled with a

suitable tracer gas and the pressure in the interspace will be monitored continuously. The interspace will be connected to the Service Vacuum System in accordance with the ITER Vacuum Handbook Section 11.

9.4. Materials

9.4.1. General

All vacuum facing materials for use in the manufacture of bellows should comply with the requirements of the ITER Vacuum Handbook. In particular materials should be selected from the ITER Vacuum Accepted Materials list (ITER Vacuum Handbook Appendix 3) and be consistent with the outgassing requirements of the ITER Vacuum Handbook section 5.4.

9.4.2. Metallic Machined Components and Fittings

All VQC 1A components which are machined from steel, austenitic steel or superalloys and which are of final thickness less than 5 mm, should be made from cross-forged material which is Electro-Slag Remelted (ESR) or Vacuum Arc Remelted (VAR) in accordance with the ITER Vacuum Handbook. The use of plate is prohibited. Alternative processes for achieving the required inclusion limits may be *accepted* if successfully validated.

The rate of inclusions in such steels should be checked in accordance with ASTM E-45 Method D (or equivalent) to be within the following inclusion limits:

- ▶ Inclusion Type A ≤ 1.0
- ▶ Inclusion Type B ≤ 1.0
- ▶ Inclusion Type C ≤ 1.0
- ▶ Inclusion Type D ≤ 1.5

Both halves of demountable flanges using metal seals are to be manufactured from cross or upset forged material.

Stainless steel knife-edge sealed flanges of any thickness for all vacuum classifications should be manufactured from cross-forged ESR grade material blanks.

All VQC 1A and 2A demountable vacuum flanges shall be made from cross-forged upset forged material.

9.5. Manufacture

9.5.1. General

Hydrostatic, rolling or elastomeric formation of bellows is *accepted* for all vacuum classes.

Non circular bellows of non edge welded construction are to be welded then formed rather than formed in parts then joined. Cross welds are to be avoided. This does not necessarily apply to the post-forming welding of bellows sections to collars where these are required.

Bellows which are of edge-welded construction may be *accepted* provided that they comply with the requirements of the ITER Vacuum Handbook Section 7.1.

9.5.2. Welding of bellows assemblies

The qualification, production and testing of welds should be in accordance with the Vacuum Handbook Attachment 1. In particular:

- ▶ Before fabrication can commence the *supplier* should prepare for approval a weld

plan in accordance with the Vacuum Handbook Attachment 1. The weld plan is a drawing which cross references each welded joint to a supporting Weld Procedure Specification (WPS).

- ▶ Welding procedures and the Procedure Qualification Records are to be qualified in accordance with Attachment 1.
- ▶ 100% visual examination of production welds should be performed.
- ▶ 100% volumetric examination of production welds should be performed, unless a method of pre-production proof sampling is *accepted*.
- ▶ Dye-Penetrant examination of production welds is only permitted in accordance with the ITER Vacuum Handbook.

9.6. Qualification of Bellows (type testing)

Prior to the manufacture of bellows assemblies the manufacturer should qualify the bellows design. The supplier should submit for *acceptance* a qualification plan (as part of the quality plan) detailing the tests to be performed on bellows assemblies. After the completion of all manufacturing processes the bellows assemblies should undergo the following qualification tests.

- ▶ Pressure test
- ▶ Mechanical shock test
- ▶ Fatigue life test
- ▶ Helium leak test
- ▶ ITER-specific tests as prescribed in the procurement specification documentation In each case,

the method of testing should be *accepted* before manufacture begins..

9.6.1. Pressure testing

Prior to leak testing it should be demonstrated that with the bellows assemblies displaced axially and radially to the maximum design values, and subjected to a 0.2 MPa pressure differential applied internally or externally to the assembly, that the bellows can survive and remain unaltered when the bellows interspace is at the following pressures

- ▶ $< 10^{-3}$ MPa (evacuated interspace)
- ▶ 0.05 MPa (interspace normal operation)
- ▶ 0.2 MPa (Interspace over pressure)

In all cases pressure testing should be followed by leak testing.

9.6.2. Mechanical shock testing

Type testing of the bellows assemblies should show no failures at 15 g acceleration after 1000 cycles under the conditions specified in 9.6.1.

9.6.3. Fatigue life tests

The *supplier* should demonstrate that the bellows assemblies will remain mechanically unaltered over the expected life of the ITER machine. Fatigue life tests should be performed under load conditions similar to the ITER loading conditions.

9.6.4. *Leak Testing*

The supplier should perform leak testing of the bellows assemblies in accordance with the ITER Vacuum Handbook. Guides to helium leak testing can be found in the ITER Vacuum Handbook Appendix 12.

Bellows assemblies for use on VQC1 systems should be baked and hot leak tested at the maximum operating temperature as follows:

- ▶ Global test of bellows assembly
- ▶ Leak test of bellows interspace (to vacuum and to atmosphere)
- ▶ Leak test of water cooling circuits (if applicable)

VQC 1A or VQC 3A components which include joints of dissimilar materials should be subjected to a minimum of three thermal cycles from ambient to the maximum possible operating temperature prior to leak testing. Normally, the time taken for any component to reach the specified bake temperature from ambient should be less than 100 hours.

Immediately after bake-out, the above tests should be repeated at ambient temperature. In both cases, the acceptance leak rate should be met with the background reading on the leak detector being at least one order of magnitude below the acceptance leak rate without electronic correction. In each case, the leak test procedure should include three operating cycles of the bellows assembly at each test temperature before leak testing.

Bellows for use on systems with VQC 2, & 4 should be subjected to the same leak testing requirements as for VQC 1 & 3, but there is no requirement to test at temperatures above ambient.

Leak rates for bellows assemblies are summarized in Table 9-1.

	Acceptance Leak Rate (Pa.m³.s⁻¹ air equivalent) at maximum operating temperature			
	VQC			
	1	2	3	4
Global leak rate	1 x 10 ⁻¹⁰	1 x 10 ⁻⁹	1 x 10 ⁻⁹	1 x 10 ⁻⁷
Bellows interspace to atmosphere	1 x 10 ⁻¹⁰	1 x 10 ⁻⁹	1 x 10 ⁻⁹	1 x 10 ⁻⁷
Bellows interspace to vacuum	1 x 10 ⁻¹⁰			
Cooling channels (if applicable)	1 x 10 ⁻¹⁰			

Table 9-1 Maximum acceptance leak rates for bellows assemblies.

9.7. Testing and Inspection of Bellows

Prior to the manufacture of bellows assemblies the *supplier* should provide for *acceptance a*

test plan and test procedures detailing the tests to be performed on bellows assemblies before delivery to the ITER site.

After the completion of all manufacturing processes and before delivery to the ITER site the bellows assemblies should undergo a vacuum baking cycle to their operating temperature and the following tests should then be carried out.

9.7.1. Leak testing

The bellows should be subject to helium leak testing in accordance with 9.6.4.

9.7.2. Dimensional inspection

The supplier shall perform a survey of the bellows convolutions to confirm compliance with the bellows technical specification. The survey results will be supplied to ITER and any non-conformance may lead to rejection of the bellows.

9.8. Cleaning

Great care has to be exercised when cleaning thin walled metal bellows, particularly those of edge-welded, nested construction. If any cleaning residues are trapped between the convolutions, either inside or outside, these can result in corrosion which can rapidly cause leaks to develop. Similarly, if any particulates are deposited in the convolutions, mechanical puncturing can take place. Alkaline degreasing solutions such as Almeco are prone to particulate precipitation and therefore must not be used for bellows assemblies.

9.8.1. Procedure for Bellows for Class VQC 1 use

The bellows should be fixed in an extended position if at all possible.

1. Any traces of visible, loose contamination should be removed with a gentle jet of clean, dry air or nitrogen.
2. The bellows should be immersed in an ultrasonically agitated bath of isopropyl alcohol (IPA) or ethyl alcohol (ethanol).
3. The bellows should be vapor washed immediately in vapor of the same solvent.
4. The bellows, including the interspace where appropriate, should be thoroughly dried inside and out using a gentle jet of clean, dry, particulate free air or nitrogen.
5. The bellows should be placed in a dry air oven at 100 °C for at least 1 hour with the interspace vented and open to atmosphere.
6. The bellows should be baked in a clean vacuum oven at a pressure $<10^{-4}$ Pa for 24 hours at 250 °C with the bellows interspace pumped or open to the vacuum environment of the oven.
7. The bellows should be sealed under dry nitrogen in a polyethylene bag.
This procedure can be used for bellows used on VQC 2, 3 & 4 systems with the vacuum bake requirement waived.

9.9. Proprietary bellows

Proprietary bellows fully meeting the ITER specification of the item and the requirements of each VQC may be allowable.

For VQC 1, 2 and 3, proprietary bellows should be supplied with an individual certificate of

conformity, stating that the item is suitable for the design, operation and test conditions as stipulated in the technical specification.

For VQC 4, proprietary bellows should be supplied with a certificate of conformity as above, but this may be in the form of generic or type conformance certificates to the catalogue specification.

9.10. Bellows Protection

Normally accessible bellows assemblies and bellows assemblies which become accessible during machine maintenance should be supplied with mechanical protection (such as the use of metal braiding or removable cover plates) to prevent accidental damage and ingress of matter to the bellows convolutions.

9.11. Marking

Surfaces which are to be exposed to vacuum should only be marked or identified if absolutely necessary, and should be marked by scribing with a clean sharp point. Seal faces should not be used. Chemical etching is an acceptable alternative for all VQC except VQC 1

Dyes, marker pens, paints, etc. should not be used on surfaces which will be exposed to vacuum. Furthermore, their use should be avoided on other surfaces to eliminate the potential for cross-contamination during subsequent cleaning operations. The use of such substances may block porosity in material and result in leaks which are initially undetectable but may open up after some time.

9.12. Packaging & delivery

Where practical, bellows assemblies should be entirely enclosed in heat sealed polyethylene and backfilled with a suitable dry gas. Bellows interspaces should be backfilled to 0.1 MPa with the connections sealed by a closed valve. Nitrogen is preferred but other gasses may be *accepted*. All bellows assemblies must be shipped dry internally and externally irrespective of final acceptance testing at the manufacturer's site.

The use of adhesive tape for the protection and packaging of components should be limited to prevent the risk of contamination from the tape. In particular tape used on austenitic stainless steel shall meet leachable chloride and fluoride limits of 15 ppm and 10 ppm, respectively. Where used tape must be fully removable, without residue, using isopropyl alcohol or acetone as the solvent.

Where practical all bellows assemblies should be transported in rigid packing cases or containers which are lined with waterproof material. Components should be packed with adequate protection from thermal and mechanical stresses (particularly shock loads resulting from dropping and mal-handling) which may adversely affect the operation of the bellows. All packing case joints should be sealed and cases marked with bellows specific identification. Handling instructions should also be clearly marked on the outside of the packaging. Any chemical or radiological hazards, etc., must be identified on the packaging. All packaging markings should be in English and French and should include the VQC of the bellows.

Incoming inspection at ITER Site.

In addition to the inspection detailed in this Appendix, bellows assemblies will be subject to

an incoming inspection on delivery to the ITER site. This will include, as a minimum, dimensional inspection for compliance with the technical specification and helium leak testing in accordance with the ITER Vacuum Handbook Appendix 12.

9.13. Documentation

The following documents should be *accepted* before premanufacture activities commence:

- ▶ Weld Plan
- ▶ Quality Plan (including test plan /schedule)
- ▶ Welding Procedures and Welder Qualifications
- ▶ Dimensional Drawings

The following documents should be *accepted* before manufacture commences:

- ▶ Type testing report

On completion of manufacturing, two sets of the following documents should be supplied as data books:

- ▶ Signed-off Quality Plan
- ▶ Welding Procedures and Welder Qualifications
- ▶ Radiographic Reports (if applicable)
- ▶ Production Proof Sample Reports (if applicable)
- ▶ Material Certificates, traceable to assemblies, in accordance with EN 10204 2.2, 3.1 or 3.2
- ▶ Dimensional drawings identifying welds
- ▶ Type testing report
- ▶ Dimensional inspection report

ITER Vacuum Handbook Appendix 10

Guideline (not under Configuration Control)

10. Requirements for the Supply of In-Vacuum Cables

Scope of this Appendix

The ITER project will include up to 80 km of in-vacuum cabling. This Appendix provides information on the various *accepted* forms of cabling for use on the ITER project for each Vacuum Quality Class, as well as general guidelines for their use.

It is intended that the *suppliers* of in-vacuum cables should follow the guidance in this Appendix to achieve the requirements of the ITER Vacuum Handbook.

The *supplier* is at liberty to utilize other techniques not described in this Appendix provided that the components manufactured comply with the requirements of the ITER Vacuum Handbook.

10.1. General

In-vacuum cabling should comply with all the general vacuum requirements for its Vacuum Quality Class (VQC). *Accepted* cable types for each VQC are listed in Table 10-1.

Use of cable insulation containing halogens is strictly forbidden for all VQC. Fluoropolymer (Teflon, Tefzel, PTFE, PFA, FEP, ETFE, etc...), PVC and Fluorosilicone sheathed cables are therefore completely forbidden.

Cable type	Vacuum Quality Class			
	VQC1	VQC2	VQC3	VQC4
Single Core Coaxial Solid Sleeved Mineral Insulated Cable (MI cable)	✓	✓	✓	✓
Multi-core Coaxial Solid Sleeved Mineral Insulated Cable (MI cable)	†	✓	✓	✓
Tri-axial Mineral Insulated cable	†	✓	✓	✓
Metal braided Fibre insulated cable	†	✓	†	✓
Ceramic coated wire	✓	✓	✓	✓
Bare wire / Non insulated cable with ceramic breads or spacers	†	†	†	†
Optical fibre Ceramic / metal coating	✓	✓	✓	✓
Polyamide, Kapton® coated cable*	✗	✓	✗	✓
Epoxy / resin insulated cable*	✗	†	✗	†
Nylon sheathed/braided*	✗	†	✗	✓
Silicon rubber insulated wire (Fluor free)*	✗	✗	✗	✗
Polyurethane, Polyethylene, Polypropylene, Polyester, Plastic *	✗	✗	✗	✗
✓ Cable accepted for use ✗ Cable prohibited from use † Restricted use conditions apply	* restriction on baking temperature to be considered			

Table 10-1 - Accepted vacuum cabling.

Any other cabling type and changes to Table Table 10-1 is subject to *acceptance* procedures as detailed in the ITER Vacuum Handbook Silver plated conductors should be avoided in VQC 1.

10.2. Mineral Insulated cable (MI)

The procurement specifications and manufacturing control plan needs to be tightly controlled and should be submitted for *acceptance* before tender in order to mitigate the potential of cabling adversely affecting the ITER vacuum.

The procedures should include:

- ▶ A high standard of cleaning for vacuum and of the handling of the constituent parts of the cable.
- ▶ Method of packing the insulant (A high and defined packing density of insulate so as to limit the void fraction ideally to <5 % this may be achieved by using preformed solid insulate rather than powder and specifying a hammering operation after each

drawing operation during manufacture).

In addition:

- ▶ Cables need to be sealed and vacuum leak tested by helium “bombing”, prior to installation. A He leak rate of $<10^{-10}$ Pa.m³/s shall be achieved.
- ▶ Cables should be proven to achieve outgassing rates of lower than 10^{-9} Pa.m³/s/m for hydrogen and 10^{-11} Pa.m³/s/m for other species at 100°C (after a 48 hour 200°C bakeout cycle for cables of <5 mm diameter).
- ▶ The use of tri-axial MI cable will be limited and subject to specific acceptance.
- ▶ The use of multi-core cable will be limited and subject to specific acceptance.

10.3. Metal braided fibre insulated cable

The use of metal braided ceramic fibre insulated cable is to be limited in VQC 1 and 3 systems and MI cable will be preferred for use whenever possible. Any proposed use requires specific *acceptance* by the ITER Vacuum Responsible Officer at the design stage.

If such cable is *accepted* for use, the procurement specification and manufacturing control plan should be submitted for *acceptance* by the ITER Vacuum Responsible Officer. This plan should ensure that manufacturing processes are tightly controlled to ensure low vacuum outgassing and should include:

- ▶ Cleaning and air bakeout of the constituent parts of the cable prior to assembly.
- ▶ Vacuum outgassing testing of the constituent parts of the cable prior to assembly.
- ▶ Control of cleanliness in assembly, in particular the use of dedicated dry machines.
- ▶ A high vacuum standard of handling component parts of the cable. In addition:
- ▶ Cables should be proven to achieve outgassing rates of lower than 10^{-9} Pa.m³/s/m for hydrogen and 10^{-11} Pa.m³/s/m for other species at 100°C (tested after a 48 hour 200°C bake out cycle for cables of <5 mm diameter).
- ▶ Possible nuclear heating of this type cable should be considered and special care shall be taken to avoid any detrimental effects on vacuum.

10.4. Other cables

Any cable used on VQC 1, 2 and 3 will be subjected to an *acceptance* criteria and to a detailed control plan. A high standard of cleaning for vacuum and of handling needs to be applied. An outgassing test should be performed prior to *acceptance*. In addition to initial vacuum compatibility of the cable, fire hazard and radiation resistance need to be considered.

- ▶ There is no limitation for Bare Wire with ceramic insulator spacers from a vacuum point of view if the cable is manufactured from accepted materials and if the appropriate cleanliness for its VQC has been achieved. From a practical point of view, it is advisable to limit their use to short distance cabling (less than 1m) and to detector internals.
- ▶ Polyimide and Kapton® coated cables are accepted for use on VQC 2 and 4, and are possible alternatives to MI or Fibre insulated cable for these VQC. PEEK outer weaving is accepted for cable bundles if required, but metallic woven sheaths are preferred.
- ▶ Any non-listed cable should undergo qualification tests prior to acceptance. Tests should, at the minimum, include a vacuum outgassing test over the whole operational

temperature range, residual gas analysis and radiation aging tests.

- ▶ Silver plated conductors are strictly limited in VQC 1, 2 and 3.

10.5. Connectors and Terminations

All Mineral Insulated cables should be of the vacuum-tight termination type (both ends), and should not be perforated. Leak tightness will be proven by helium “bombing” of the cable, followed by leak detection. A leak rate of $<10^{-10}$ Pa.m³/s is to be obtained. If the cables are part of a feedthrough assembly, the full feedthrough assembly should be leak tight to $<10^{-10}$ Pa.m³/s.

Cable terminations made after crossing a boundary for VQC 1 and VQC 2 systems should be within a suitable termination vacuum enclosure connected to the SVS. This space can be within a feedthrough interspace and is to be connected to the SVS by 2 connections (½ inch VCR™ couplings are envisaged).

In-vacuum connectors should be designed for vacuum compatibility and are to comply with the general vacuum requirements for the relevant VQC. This includes, among other factors: design, materials, manufacturing process, cleaning and outgassing.

10.6. Cable Routing

It is not permitted for cables to pass across a pressure boundary to atmosphere.

The following considerations should also be taken into account when routing the cables.

- ▶ The routing scheme should offer good protection against damage to cables. Loops should be properly designed to permit adequate gas pumping, whilst protecting the cables from external contamination.
- ▶ The routing should offer appropriate thermal contact of the cable with cooled components to avoid any overheating of the cables that might affect vacuum performance or cable integrity.
- ▶ Thermal expansion and contraction of cabling shall be considered in the design.
- ▶ High voltage cables and signal cables shall be separated where possible.

10.7. References

- [1] ITER D 22H4HUv1.0, FDR01-DDD18 31 Vacuum Pumping and Fuelling
- [2] R. J. H. Pearce and Al. Fusion Engineering and Design 82 (2007) 1294–1300 – “ITER relevant outgassing and leakage from different types of in-vessel cabling”
- [3] G. Vayakis and Al., ITER IT, JAERI NAKA, N 55 RI 37 04-02-19 W 0.1
- [4] R. Pearce and Al., UKAEA, TW3-TPDS-DIADEV, ITER D222N5N
- [5] G 55 MD 32 98-06-02 F 1, “Table 2.4.1-2 - cable specifications”
- [6] G 55 MD 37 98-06-03 W 0.1, “Table 2.4.4-1 - cable for use in-vessel”
- [7] G 55 MD 5 96- 12-11 W 0.1, DIAGNOSTIC ENGINEERING NOTE 19

ITER Vacuum Handbook Appendix 11

Guideline (not under Configuration Control)

11. Standard Vacuum Pipe and Pipe Fitting Dimensions

11.1. Introduction

The IO vacuum pipework systems are designed and constructed to the ASME B31.3 (2010) designated for fluid cat. (M) and NF EN13480 codes.

Pipe and pipefittings (tees, elbows etc.) for use on the IO vacuum systems shall meet the technical requirements as specified in the Technical Specifications [1].

11.2. Scope

The scope of this document is to detail the dimensions for standard pipe and pipefittings (tees, elbows etc.) for use on the IO vacuum systems and to define the weld preparation to be used in fabrication of IO vacuum pipework systems.

The use of pipe and/or pipefittings with dimensions not listed in this document requires *acceptance* [2].

11.3. Dimensions

11.3.1. Standard Pipe

Standard pipe dimensions for use on IO vacuum systems that comply with dimensions as specified in [3] are synopsized in Tables 1, 2, 3.

Standard pipe dimensions for use on IO vacuum systems that comply with dimensions as specified in [4] are synopsized in Table 4 with “Outer Diameter Tolerances” and “Wall Thickness Tolerances” specified in Tables 4-a and 4-b.

11.3.2. Standard Pipe Fittings

Standard pipe fittings (tees, elbows etc.), for pipe dimensions as specified in [3], for use on IO vacuum systems shall comply with dimensions as specified in [5].

11.4. Weld Preparation

The dimensions weld bevels for pipe and pipe fittings shall comply with ASME B16.9 “Plain Bevel” as described in Figure 1.

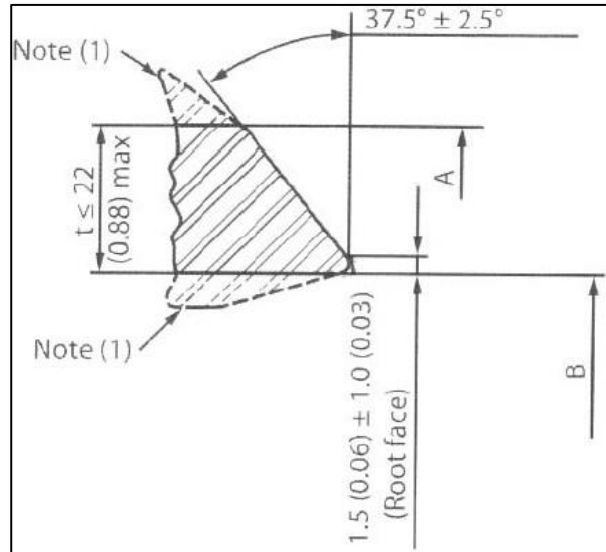

Figure 1 ASME B16.9 Plain bevel.

General Notes:

- a. Dimensions in parenthesis are in inches
 - b. Other dimensions are in millimeters.
- Note (1) See ASME B16.9 for transition contours.

11.5. Bibliography

- [1] Supply of Seamless Stainless Steel Pipework and Pipework Components to the ITER IO (ITER_D_R22L3M).
- [2] ITER Vacuum Handbook (ITER_D_2EZ9UM).
- [3] ASME B36.10M, 2004.
- [4] NF EN ISO 1127, 1996.
- [5] ASME B16.9M, 2012.

Table 1: Pipe Dimensions Schedule 10s

DN	Sch	Nominal Wall thickness (mm)	Permissible variation in wall thickness (% from nominal), mm		Outer diameter, (mm)	Permissible variation in outer diameter (mm)		
			Over	Under		Over	Under	
16[#] 15		2.11	(20.0), 0.42	(12.5), 0.26	21.30	0.4	0.8	
40	10s	2.77	(20.0), 0.55	(12.5), 0.35	48.30	0.4	0.8	
63[*] 65		3.6 3.05	(20.0), 0.72	(12.5), 0.45	71.06 73.00	0.8	0.8	
100		3.05	(22.5), 0.69	(12.5), 0.38	114.30	0.8	0.8	
160^{**} 150		3.0 3.4	(22.5), 0.67	(12.5), 0.37	159.00 168.30	1.6	0.8	
200		3.76	(22.5), 0.85	(12.5), 0.47	219.10	1.6	0.8	
250		4.19	(22.5), 0.94	(12.5), 0.52	273.00	2.4	0.8	
300		4.57	(22.5), 1.02	(12.5), 0.57	323.80	2.4	0.8	
320		As DN 300						

[#] Where specified in the design that DN 16 pipe is required the dimension of said pipe and/or fittings shall be that of DN15.

^{*} Where specified in the design that DN 63 pipe is required the dimension of said pipe and/or fittings shall be that of DN65.

^{**} Where specified in the design that DN 160 pipe is required the dimension of said and/or fittings pipe shall be that of DN150.

Table 2: Pipe Dimensions Schedule 20s

DN	Sch	Nominal Wall thickness (mm)	Permissible variation in wall thickness (% from nominal), mm		Outer diameter, (mm)	Permissible variation in outer diameter (mm)	
			Over	Under		Over	Under
16[#]	20s	2.11	(20.0), 0.42	(12.5), 0.26	21.30	0.4	0.8
15							
40		2.77	(20.0), 0.55	(12.5), 0.35	48.30	0.4	0.8
63[*]		3.05	(20.0), 0.61	(12.5), 0.38	71.06 73.00	0.8	0.8
65							
100		6.35	(15.0),	(12.5),	114.30	0.8	0.8
160^{**}		6.35	(22.5) , 1.42	(12.5) , 0.79	159.00 168.30	1.6	0.8
150							
200		6.35	(22.5), 1.42	(12.5), 0.79	219.10	1.6	0.8
250		6.35	(22.5), 1.42	(12.5), 0.79	273.00	2.4	0.8
300	6.35	(22.5), 1.42	(12.5), 0.79	323.80	2.4	0.8	
320	As DN 300						

Where specified in the design that DN 16 pipe is required the dimension of said pipe and/or fittings shall be that of DN15.

* Where specified in the design that DN 63 pipe is required the dimension of said pipe and/or fittings shall be that of DN65.

** Where specified in the design that DN 160 pipe is required the dimension of said pipe and/or fittings shall be that of DN150.

Table 3: Pipe Dimensions Schedule 40s

DN	Sch	Nominal Wall thickness (mm)	Permissible variation in wall thickness (% from nominal), mm		Outer diameter, (mm)	Permissible variation in outer diameter (mm)		
			Over	Under		Over	Under	
16[#] 15	40s	2.769			21.30	0.4	0.8	
40		3.68	(20), 0.74	(12.5), 0.46	48.30	0.4	0.8	
63[*] 65		3.6 5.16	(20), 0.72	(12.5), 0.45	71.06 73.00	0.8	0.8	
100		6.02	(15.0), 0.9	(12.5), 0.75	114.30	0.8	0.8	
160^{**} 150		3.0 7.11	(22.5), 0.67	(12.5), 0.37	159 168.30	1.6	0.8	
200		8.18	(22.5), 1.84	(12.5), 1.02	219.10	1.6	0.8	
250		9.27	(22.5), 2.09	(12.5), 1.16	273.00	2.4	0.8	
300		10.31	(22.5), 2.32	(12.5), 1.29	323.80	2.4	0.8	
320		As DN 300						

Where specified in the design that DN 16 pipe is required the dimension of said pipe and/or fittings shall be that of DN15.
^{*} Where specified in the design that DN 63 pipe is required the dimension of said pipe and/or fittings shall be that of DN65.
^{**} Where specified in the design that DN 160 pipe is required the dimension of said pipe and/or fittings shall be that of DN150.

Table 4: Pipe Dimensions

Outside Diameter (mm)	Wall Thickness (mm)					
	1.0	1.2	1.6	2.0	2.6	3.2
6	Y	Y	-	-	-	-
8	Y	Y	-	-	-	-
10	Y	Y	-	-	-	-
12	Y	-	Y	Y	-	-
14	Y	-	Y	Y	-	-
16	Y	Y	Y	Y	-	-
18	Y	-	Y	Y	-	-
20	Y	Y	Y	Y	-	-
22	Y	-	-	Y	-	-
25	Y	Y	Y	Y	Y	-
30	-	-	Y	Y	-	-
32	-	Y	-	Y	-	-
35	-	Y	-	Y	-	-
38	-	Y	Y	Y	Y	Y
40	-	Y	Y	-	Y	-
Y indicates availability.						
NOTE: Pipes of wall thickness less than 2.0 mm designed to contain cryogenic helium, Electro-Slag Remelted (ESR) or Vacuum Arc Remelted (VAR) material (or equivalent process demonstrated to achieve similar inclusion size and number) shall be used for the pre-extruded material with inclusion limits as specified in [2].						

Table 4-a: Outer Diameter Tolerances applicable to Pipe Dimensions presented in Table 4

Tolerance Class	Tolerance on Outside Diameter
D1	$\pm 1.5\%$ with ± 0.75 mm min.
D2	$\pm 1.0\%$ with ± 0.50 mm min.
D3	$\pm 0.75\%$ with ± 0.30 mm min.
D4	$\pm 0.5\%$ with ± 0.10 mm min.

Table 4-b: Wall Thickness Tolerances applicable to Pipe Dimensions presented in Table 4

Tolerance Class	Tolerance on Wall Thickness
T1	$\pm 15\%$ with ± 0.60 mm min.
T2	$\pm 12.5\%$ with ± 0.40 mm min.
T3	$\pm 10.0\%$ with ± 0.20 mm min.
T4	$\pm 7.5\%$ with ± 0.15 mm min.
T5	$\pm 5.0\%$ with ± 0.10 mm min.

ITER Vacuum Handbook Appendix 12

Guideline (not under Configuration Control)

12. Guide to Leak Testing of Components

12.1. Scope and Status

As an Appendix to the ITER Vacuum Handbook, the status of this document is advisory and not mandatory on the supplier of any component. Nevertheless, it is strongly advised that the requirements of this document are adhered to for the supply of vacuum components to ITER.

The purpose of this Appendix is to define the criteria for the leak tightness of vacuum related components supplied to ITER. It is applicable to equipment destined for use on the ITER facility and any other area on site, which utilizes items and assemblies with a vacuum boundary. It defines the test criteria and gives general instruction and guidelines to those persons, be they on site at the supplier, on site at ITER, or as part of an off site organization which is called upon to perform vacuum helium leak detection.

12.2. General

Tests shall be performed both at ambient temperature and at the maximum and minimum working temperatures of the component, with the pressure differential in the same direction as for operation of the component. Where possible, component parts shall be tested before assembly. However, final assemblies must also be tested.

Where it is not envisaged that leak tests will be performed at cryogenic temperatures on vacuum components which are for use on cryogenic systems, a method of “thermal shocking” of welded connections shall be agreed in advance.

The supplier is responsible for all jigs, seals and equipment to allow the leak tightness to be proven across all vacuum boundaries, unless otherwise stated in the contract. Where pressure testing is required, this must always be performed prior to final vacuum leak testing. Acceptance tests shall wherever possible use the same type of seal which shall be used after installation of the component.

The supplier is responsible for the supply of tooling and methodologies for the subsequent removal of jigs, seals, temporary closure plates, etc., which have been fitted to components to facilitate the leak testing of such components.

The leak test method shall be agreed in advance with ITER. This will involve the submission for approval of a procedure as part of an external supply contract. The procedure should describe how the leak test will be performed, and include configuration diagrams and full details of the equipment to be used etc.

The ITER Vacuum Responsible Officer (RO) will nominate a Vacuum Specialist to witness

the acceptance leak tests and any other leak test deemed necessary as part of a manufacturing process.

In no circumstance shall *any* vacuum equipment be installed without an *accepted* pre-installation leak check being performed at the ITER site, without the express permission of the ITER Vacuum Responsible Officer. This applies to *all* Vacuum Quality Classifications.

12.3. Leak testing Methodologies

This Appendix describes recommended procedures for carrying out the most widely used methods of helium leak testing; it does not consider all available methods. Other methods may be used, but only with the prior approval of the ITER Vacuum RO

12.3.1. Over Pressure Methods

Over-pressure methods enable thin-walled vacuum chambers to be leak tested which might otherwise collapse under vacuum. This method is also useful when the equipment to be tested is already filled with a gas which can be used as the test gas. However the test gas which flows out through any leaks always mixes with contaminants present in the air, and this might reduce sensitivity.

12.3.1.1. Mass Spectrometer Sniffing Probe

Helium, or some other suitable gas, is used to slightly pressurize the component to be tested and a sampling probe “sniffs” for leaks. Helium passing through the leak is sampled from the surrounding atmosphere through a long narrow flexible tube which is connected to a mechanical pump to give a drop in pressure from atmosphere to about 10^{-2} Pa at the ion source of a mass spectrometer detector. Traces of helium or halogen in the environment can also be detected, which may lead to errors in the measured leak rate.

The helium content of atmospheric air limits the sensitivity of the sampling probe, and the detection limit is typically $\sim 1 \times 10^{-7}$ Pam³s⁻¹ if the volume is filled with pure helium (or the tracer gas appropriate for the detector used such as argon).

The sampling tube should be as short as possible to reduce the response time of the gas flow of the air-helium mixture from the entrance of the tube to the detector. The flow rate may also be limited by the available pumping throughput.

12.3.1.2. Probe Leak Testing (vacuum box or suction cup method)

Open objects can be tested using the vacuum box or suction cup method. A partial enclosure which can be evacuated by a leak detector is tightly pressed against the wall of the component being tested. The enclosure is evacuated and helium tracer gas applied to the opposite surface of the wall by a spray gun or other means. Helium leaking through the wall can pass to the detector via the vacuum box. This method of leak detection is widely used for the testing of welds on incomplete enclosures. The sensitivity is usually limited by diffusion of helium through the seal between the evacuated enclosure and the component wall.

12.3.1.3. Pressurization – Evacuation (“bombing”) Test

Hermetically sealed objects which cannot be pumped out can be leak tested using the so-called “bombing” method. The component to be tested is subjected to a high pressure of tracer gas, usually helium, to force gas into the component through any leaks present. After flushing to remove adsorbed tracer gas from the surface of the component, it is placed in a vacuum chamber which is connected to a leak detector. This can then detect any tracer gas passing out of the sealed volume through the leaks. This method is usually employed as a “go/no go” test since it is very difficult to locate the position of any leaks on such components.

12.3.2. Vacuum Leak Detection Methods

12.3.2.1. Pressure Rise Test

A pressure rise test is a useful way of determining the overall magnitude of any leaks present in a component.

A vessel to be tested of volume V is evacuated and sealed off. The pressure rise ΔP is measured over a time interval Δt and the leak rate q_L (at constant temperature) is evaluated from:

$$q_L = V \cdot \frac{\Delta P}{\Delta t}$$

This calculated leak rate also includes contributions from any other gas sources such as virtual leak and outgassing.

Real leaks may be distinguished from other sources of pressure rise since a real leak gives a pressure rise which is strictly proportional to time, while virtual leaks and outgassing result in an initially rapid pressure rise which tends to level off after some time

12.3.2.2. Helium Leak Detectors

These are based on a mass spectrometer, usually a small magnetic sector device. Leak detection can begin only when high vacuum conditions are obtained in the mass spectrometer. Due to its high sensitivity this method is the most frequently used method of leak detection for vacuum applications. The inlet pressure at the entrance to the leak detector depends on the design of the unit, but can range from atmosphere down to about 10^{-4} Pa.

Helium is usually used as the tracer gas, but other gases such as argon, neon, krypton, hydrogen and mixed gases may be used with the mass analyser suitably tuned. Modern helium leak detectors are usually supplied with the capability of detecting H_2 , He^3 , and He^4 .

To increase the helium detection sensitivity and improve detector stability, the mass analyser in helium leak detection systems is often de-tuned to give lower mass resolution. This can lead to a contribution to the measured mass 4 intensity from mass 2 and mass 3, thus giving a higher leak detector background signal at mass 4. For large component leak testing at high sensitivity, it may be necessary to reduce the partial pressure of hydrogen at the analyser

by selectively pumping it with a getter in series with the leak detector input. It may also be necessary to selectively pump condensable gasses at the leak detector inlet. This can be achieved by the addition of a cold (e.g. liquid nitrogen) trap in series with the inlet.

12.4. Procedure for Helium Leak Tightness and Testing

12.4.1. Equipment

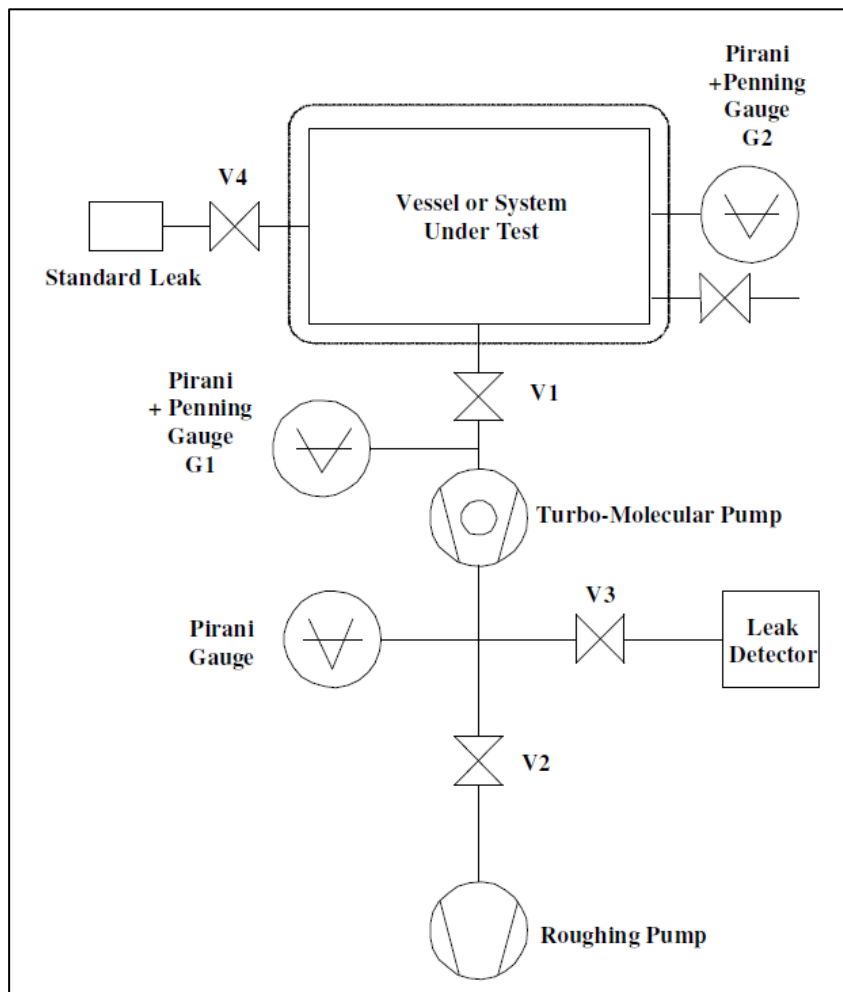

Figure 12-1 Typical Leak Detection Equipment.

12.4.2. Pumping System

An indication of the basic elements of a pumping system, which could be used for leak detection, is illustrated in Figure 12-1. In this form it consists of the following items: -

1. A turbo-molecular pump isolated by a valve V1 and backed by a roughing pump via a valve V2, of enough pumping capacity to pump the system under test down to a suitable pressure at the inlet of the leak detector. Ideally all fittings and seals (at least those on the high vacuum side) should be all-metal to alleviate the problem of helium

permeation.

2. A Pirani gauge to measure the pressure in the backing line of the turbo-molecular pump and a pressure gauge system (G1) on the high vacuum side of the turbo-molecular pump (but below valve V1) capable of measuring in the range 0.1 MPa to 10^{-7} Pa.
3. Possible additional options to this pumping system could include a quadrupole or other type of mass spectrometer to measure the residual gas spectrum. This is essential if system cleanliness is to be assessed. A hydrogen getter and liquid nitrogen trap may be used to lower the detector background signal.

A vent valve on the vessel side of V1 is also advisable for venting the item under test to a clean dry gas such as nitrogen to retain cleanliness.

12.4.2.1. Detection System

This is the system used to detect any vacuum leaks which may be present, thus it is the central part of the system and normally consists of the following items:

1. A helium mass spectrometer leak detector installed such that it can be connected into the backing line of the turbo-molecular pump through valve V3. For maximum leak detection sensitivity, it should provide the necessary backing pressure for the turbo-molecular pump. It therefore should have its own pumping system comprising a turbo-molecular and backing pump combination. It must be able to detect leaks at least one order of magnitude smaller than that required by the specification of the item under test, and up to at least $100 \text{ Pam}^3\text{s}^{-1}$.

It should be noted that with modern leak detectors, it is possible to suppress the background and gain up to 2 orders of magnitude in sensitivity. Although this mode is useful in localizing leaks, it shall not be used for the purpose of acceptance testing without prior approval by the ITER Vacuum RO.

An alternative when the item under test is of relatively small volume of less than 1 m^3 , and when only a simple cold leak test is required, is to use the mass spectrometer leak detector on its own. In this case the leak detector is connected directly to the item under test. The separate turbo-molecular and roughing pump system is not required.

If there is a large leak on the item to be tested or where the pumping system is incapable of pumping the item under test to a sufficiently low pressure for the leak detector to be connected directly to the backing line of the turbo molecular pump, valve V2 may be left open and valve V3 partially opened so that the leak detector samples part of the gas stream to the backing pump. This configuration may be used to locate, but not size, any leaks.

2. A pressure gauge system (G2) on the vessel under test, capable of measuring in the range 0.1 MPa to 10^{-7} Pa.
3. A calibrated helium standard leak of value commensurate with the magnitude of leak rate required by the specification of the item under test, mounted on the system under test, and isolated by valve V4. Traceable calibration certificates shall be kept

for this item and these should be readily available.

4. A helium bag or other enclosure fashioned in such a way that the test gas can surround all parts of the item under test with a concentration preferably exceeding 50% in air.
5. A system for continuous recording of the leak test process. This can be achieved by using an analogue recording device such as a paper strip chart recorder connected to the output of the helium mass spectrometer leak detector or by continuous logging (and display) of data on a computer or dedicated data logger.

12.4.2.2. Miscellaneous

The following equipment is optional but experience has shown the items to be of use in helium leak tests.

1. A standard vacuum cleaner to pump the helium enclosure out if it is a sealed collapsible type such as a plastic bag before inflating it with helium, to ensure maximum concentration of the helium in the enclosure.
2. A helium-in-air concentration monitor to ascertain the percentage of helium in the bag or other enclosure during the test.
3. A triggered helium spray gun for subsequent probe testing of the item to localize any leaks found during the global leak test.

12.4.3. Preliminaries

12.4.3.1. Initial Checks on the Leak Detection System

1. With valve V2 open and valves V1 and V3 closed, the roughing pump is started. When the pressure falls to a suitable level, the turbomolecular pump is started and left until the pressure on gauge G1 stabilizes.
2. The leak detector is switched on and when it is ready, an internal calibration is carried out as per the manufacturer's instructions.
3. The backing line Pirani gauge pressure reading is noted and valve V3 is carefully opened so that the leak detector does not trip out. (Most modern leak detectors can cope with this.)
4. The roughing pump valve V2 is closed.
5. When a relatively stable reading has been obtained on the leak detector, a leak check is carried out, by using a helium gun to probe with helium gas all joints and welds up to and including the pumped sides of V1 and V3.
6. If any leaks are found of magnitude greater than one decade smaller than the maximum leak rate called for in the specification of the item under test, then these shall be rectified and this sequence repeated until no such leaks are found.

12.4.3.2. Pump-down

Before the leak test can be undertaken, the item under test must be pumped down to the requisite pressure. In the case of the system shown in Figure 12-1 which uses a turbomolecular and roughing pump set, the following actions shall be performed.

1. The roughing pump is started and valves V1 and V2 are opened.
2. When the system Pirani pressure reaches the level given in the manufacturers instructions the turbo-molecular pump is started.
3. The system is ready for initial tests when the pressure reaches 10^{-3} Pa or lower on G1, or such other pressure specified as suitable by the manufacturer of the leak detector. If it does not reach this pressure then there may be a large leak present which must be located and rectified. It should be located using either an overpressure technique as described in Section 12.3.1.1 or the procedures of Section 12.4.5.2 but with valve V3 only partially opened so that the pressure at the inlet of the leak detector remains below the upper pressure limit specified by the manufacturer with the gas flowing to the roughing pump being sampled into the leak detector.

12.4.3.3. Background Determination

After a stable pressure reading has been obtained on gauge G2 with valves V1 and V2 open and the turbomolecular pump set running normally, with the leak detector fully functioning and the data logging device connected and operating, then the roughing valve V2 is closed and the leak detector valve V3 opened.

The leak detector reading is monitored until it has stabilised, without any electronic correction. This should take around 10 minutes, but the time can be longer depending on the size of the system under test.

This reading is recorded as the background level. Any reading above this value during the overall test constitutes a positive indication of a leak.

12.4.4. Leak Detector Calibration

With the system in the state as above for background determination, leak detector calibration shall be performed.

Valve V4 is carefully opened and the reading on the leak detector monitored until it is stable. This should correspond to the value of the standard leak to within $\pm 5\%$ after suitable corrections for the age of the standard leak and its temperature have been applied.

If a response time measurement is not required, then V4 is closed and the reading should then return to the background level.

12.4.4.1. Response and Cleanup Time Measurement

This should be done for a large system or where there is a long path length involving small bore tubes. This ensures that the duration of the overall test will be valid.

1. With the standard leak open to the system and the leak indication stable at the value of the standard leak, suitably corrected for age and temperature, valve V4 is closed.
2. The time taken for the reading on the leak detector to return to the background level is recorded. This is the cleanup time for the system and will depend on the applied pumping speed for helium and the configuration of the system under test.
3. When the background level has been attained, valve V4 is opened and the time taken

to return to the level of the standard leak indication, suitably corrected, is recorded. This is the response time for the system.

4. Valve V4 is closed and the system is allowed to return to the background level.
5. This concludes the initial set-up tests and the overall leak test may then be undertaken.

12.4.5. Cold Leak Tests

12.4.5.1. Global Leak Check

If all the preceding conditions have been met with all equipment functioning and ready for use, a global cold leak test may be carried out according to the following procedure.

1. The data recording system is connected to the output of the leak detector and started and the date and time are recorded.
2. Valves V1 and V3 are opened and valves V2 and V4 are closed.
3. When the background reading is stable and is at a level consistent with the leak specification of the item under test, which will be for most purposes at least an order of magnitude lower than the specified maximum leak rate of the component under test and without electronic correction, the global leak check may be started.
4. The component under test is surrounded by a suitable helium enclosure. If the helium enclosure is a flexible type, it should have as small a volume as possible. The enclosure is filled with helium to a concentration of at least 50% in air and the time is recorded in the data log
5. Helium should remain in contact with the item under test for at least 10 minutes or longer, depending on the size of the object and the response time previously measured, or for the time specified in the test specification for the component under test, whichever is longer.

In the case of components where there might be possible low conductance leak paths, for example porosity, the time required for a sensible test may be significantly longer than the response time measured for the system using the techniques of Section 12.4.4.1. Details of the method and time of duration of helium application shall be included in the leak testing procedure to be *accepted* by the ITER Vacuum Responsible Officer.

6. Where the helium enclosure is not completely sealed, then suitable precautions shall be taken to ensure that helium cannot back-diffuse through the roughing pumps and/or the leak detector pumps into the mass spectrometer detector. In the case of long-duration global tests, it may be advisable to house these items in a separate enclosure held at a small positive pressure above atmosphere.
7. After the appropriate time interval, the helium supply is closed off (where appropriate), and the enclosure vented to atmospheric air and removed. The time is recorded in the data log.
8. If the leak rate indication on the leak detector has not risen by more than the specified maximum leak rate at any time during this test procedure, the item under test shall be deemed to have passed, subject to the requirements of Section 12.4.5.3.
9. It may be advisable to recheck the background reading and leak detector

calibration if the global test has been of significant duration. When that has been done according to the procedures of 12.4.3.3 and 12.4.4, then the global leak test is complete.

10. Valves V1 and V3 are closed and valve V2 opened.
11. The item is vented, or left under vacuum for further work as required.
12. If the leak rate reading during the test has at any time exceeded the specification value, then the item has failed the test, and the leaks shall be located using the procedures of Section 12.4.5.2.

12.4.5.2. Probe Tests

These are necessary to locate any leaks greater than the value in the specification of the component being tested which may have been indicated during the global test. They may be required not only at this stage, but may be needed also after the hot global test and the final cold global test, if those two tests are required as part of the contract or other instruction.

The following procedure shall be used, although others are possible and may be used after prior agreement.

1. Any helium enclosure or other covering or obstruction is removed from the item under test wherever possible.
2. If the component under test is at cryogenic temperatures, it may have to be warmed to ambient temperature before probe tests can be carried out.
3. Valves V1 and V3 should be open and valves V2 and V4 should be closed.
4. In the case of a large item, the data logging system shall continuously record the leak detector signal so that any longer term variations in leak rate may be observed.
5. Using a helium gun, helium gas is sprayed over or into all suspect locations and under any non-removable coverings, starting at the top of the item under test and working down as required. The helium spray should be introduced to the area under test for a time period consistent with the response time of the system measured in accordance with Section 12.4.4.1.
6. If a leak indication is found, then the point of maximum reading shall be localized. For subsequent testing to localize any other leaks, it is advisable to blanket that point with a physical barrier such as a polythene bag or sheet or with a stream of another gas whilst checking the remainder of the system.
7. When all detectable leaks have been located, then the leak detector is isolated by closing valve V3. Valve V1 is closed and the item under test shall be vented to dry nitrogen or clean dry air admitted through the vent valve. The ITER Vacuum Responsible Officer shall be contacted to agree a procedure to rectify the leak or leaks.
8. When any agreed repair has been successfully accomplished, the process starting from stage 12.4.3.2 and to point 10 at the end of stage 12.4.5.1 is repeated until the item is proved to meet the relevant specification.

12.4.5.3. Acceptance Criteria

If all the stages above have been successfully completed then the item under test may be accepted by the ITER Vacuum Specialist as having met the relevant specification provided that the following conditions have been met.

1. The leak detector has been correctly calibrated and its calibration value is within $\pm 5\%$ of the standard leak rate value as corrected for the ambient temperature and the age of that item and that standard leak rate value is commensurate with the value of the maximum leak rate specified for the item under test.
2. The leak test has been performed by suitably qualified and experienced personnel to the *accepted* procedure, with no significant deviation from that procedure and has been witnessed by the ITER Vacuum Specialist.
3. The leak rate value as measured by the leak detector has not increased in value above the measured background to a value greater than the specified leak rate during the entire duration of the global leak test.

The location and magnitude of all identified leaks shall be recorded. Normally, all practicable efforts shall be made by means agreed with the ITER Vacuum Responsible Officer to reduce any leak discovered during the manufacturing phase to a level lower than the limit of detection of the leak detection method used for the tests.

12.4.6. Hot Leak Check

12.4.6.1. Test Conditions

If it is required as part of the contract or other instruction to perform a hot leak test on an item which during its life may be subject to increased temperature usage, then the following procedure shall be carried out.

1. Before commencing any part of this leak test procedure, the item under test must have completed one or more temperature cycles as specified and be at that point on the cycle where it is specified that the hot leak test shall take place.
2. The leak detector shall be set up using the procedures of Sections 12.4.3.3 and 12.4.4. If the response time of the system has already been determined, or is not required, it need not be re-measured.
3. If the background is elevated when the item under test is at temperature (as may often be found), then the conditions stipulated in 12.4.5.1 Point 3 may not be met. However with judicious choice of scale it may be possible to do a perfectly valid leak check at a raised background level. It may also be necessary to selectively pump hydrogenic species from the leak detector input gas stream. This can be done by the correct choice of getter installed in series with the leak detector inlet. The applicable conditions for this test must be agreed with the ITER Vacuum Responsible Officer.
4. The helium enclosure used for these tests must be capable of tolerating temperatures above ambient since the increased thermal conductivity of helium will raise the temperature of this item above the level it would reach with only

atmospheric air in the enclosure.

12.4.6.2. Global Leak Check with the Component under test Hot

Essentially, this is a repeat of the cold global leak test described in Section 12.4.5.1 except that, if a leak indication is observed, the item may need to be cooled down before probe tests can be performed. The temperature at which the hot leak test is performed shall be recorded and shall be within the limits as specified in the leak testing procedure.

If, with the component at the specified hot temperature, no leak rate of size greater than that specified for the component has been observed, then provided that the conditions of Section 12.4.5.3 have been met, the component will be deemed to have satisfied the hot leak test requirement.

If, however, with the component at the specified hot temperature, a leak rate of size greater than that specified for the component has been observed, then a probe test to localise any leaks present must be undertaken.

The supplier should be aware that under some conditions, a leak may be observed at temperature but may disappear when the component is cooled to ambient temperature. If this is the case, then it may be necessary to implement an agreed procedure for leak location at elevated temperature.

12.4.6.3. Probe Test

1. This method of probe leak testing baked components is the essentially the same procedure as detailed in 12.4.5.2., but with additional steps as noted below:
2. If the probe test cannot be carried out at the hot temperature, the component shall be cooled to ambient temperature
3. Steps 1 - 7 of section 12.4.5.2 shall be carried out.
4. If, after probe testing at ambient temperature, no leak has been identified, then, as agreed with the ITER Vacuum Responsible Officer, a further temperature cycle shall be completed as specified up to the point on the cycle where it is specified that the hot leak test shall take place.
5. Then either
 - a. an agreed procedure for leak location at this elevated temperature shall be carried out
 - or
 - b. the component shall be cooled and step 2 of this Section shall be carried out in the hope that the hot leak may have opened up further and now may be detectable at or close to ambient temperature.
6. Step 5 shall be repeated until no leaks which have not been localised are evident at the hot temperature.
7. When all detectable leaks have been located and the component is close to ambient temperature, then the leak detector is isolated by closing valve V3. Valve V1 is closed and the item under test shall be vented to dry nitrogen or clean dry air admitted through the vent valve. The ITER Vacuum Responsible Officer shall be contacted to

agree a procedure to rectify the leak or leaks.

8. When any agreed repair has been successfully accomplished, the global hot leak test procedure of this Section is repeated.

12.4.6.4. Final Cold Acceptance Check

This test shall be carried out following a satisfactory global hot leak test procedure when the item under test has cooled down to a temperature in the range 60°C to 80°C, since experience has shown that small leaks can be blocked by water vapour below this temperature.

It shall follow the procedures of Section 12.4.5.1.

12.4.6.5. Acceptance Criteria

These shall be the same as those specified in Section 12.4.5.3.

12.5. Responsibilities

It shall be the responsibility of the supplier to ensure that all vacuum leak tests carried out off-site and of the ITER Vacuum Responsible Officer when such tests are carried out on-site that they be performed in accordance with the contract or other specification. All deviations from such specification or agreed variation thereof shall require a non-conformance to be raised covering each specific case. In the case of any particular component, a nominated ITER Vacuum Specialist may witness the tests.

All records as detailed in the following section shall be completed and shall become part of the final document package for the component concerned.

12.6. Reporting

Full records of the tests carried out on any component shall be completed in order to maintain traceability of the leak test history of a particular item. The records shall consist of the following.

1. Data records of the output of the leak detector for all the global tests specified including the standard leak calibration and response time determination. These data records shall include the date and time of all tests as well as anything else of relevance, such as the start and finish time of helium gas application to the item under test.
2. A record of the helium concentration during the leak test where that is required. In the case of a simple cold leak test this will be on request of the ITER Vacuum Responsible Officer, but in the case of a full cycle of leak testing involving temperature variation it will be required.
3. A record of the system total pressure throughout a temperature cycle since it may pinpoint the time when a leak opened up and be instrumental in the subsequent diagnosis of the leak.
4. The make, model and date of manufacture of the helium mass spectrometer leak detector used in the tests.
5. The nominal value of all standard leaks used, their date of calibration, ageing and

temperature characteristics, and the ambient temperature(s) experienced during the tests.

6. The results of all tests showing whether it was a pass or fail, and, if a failure, the measured leak rate and the location of the leak, together with the steps taken for any repair or elimination.

The magnitude and location (if applicable) of *all* leaks identified during testing shall be recorded. This includes leaks of magnitude lower than the acceptance criteria for which no remedial action may have been taken.

ITER Vacuum Handbook Appendix 13

Guideline (not under Configuration Control)

13. Guide to Cleaning and Cleanliness for the Vacuum Components

13.1. Scope

As specified in the ITER Vacuum Handbook all vacuum components to be supplied to ITER are subject to the provision of a “clean work plan” and cleaning procedures. This requirement is waived for proprietary components which are compliant with the mandatory requirements of the ITER Vacuum Handbook and are supplied to ITER with Certification of Conformity.

This Appendix specifies typical processes which conform to the requirements of the ITER Vacuum Handbook for the cleaning of vacuum vessels, components and assemblies which are required for the ITER Project. This covers vacuum vessels and any item which will be in a vacuum environment, whether individually or made up into assemblies containing a number of such items.

This guide is intended to assist the *supplier* of vacuum components to ITER in the preparation of a clean work plan and cleaning procedures for submission to ITER for *acceptance*. Following the guidance in this Appendix should help *suppliers* to achieve the requirements of the ITER Vacuum Handbook.

The *supplier* is at liberty to utilize other techniques not described in this Appendix provided that the components manufactured comply with the requirements of the ITER Vacuum Handbook.

13.2. General Cleaning Requirements

In general, all components classified as VQC1 will need cleaning to Ultra High Vacuum standards. Those components classified as VQC2, VCQ3 and VCQ4 will generally be operated in less stringent vacuum environments and will therefore not require cleaning to such rigorous standards.

However, it is the responsibility of the *supplier* to satisfy themselves that they understand fully the implications of cleaning to the requisite standard.

Any proposed deviation from the procedures and processes described in this Appendix need to be *accepted* in writing by ITER. This is particularly important where the use of any chemical product (solvent, etchant, detergent, etc.) other than those specified is proposed.

13.3. Health and Safety

Some of the chemicals or equipment used in cleaning processes may be classified as hazardous.

It is the responsibility of the *supplier* to satisfy themselves that any cleaning procedure complies fully with local legislative and regulatory standards regarding health and safety of any or all processes used and that all operatives have received the necessary training.

The *supplier* shall have the responsibility of ensuring that all staff fully understand all health and safety information issued by the manufacturer or *supplier* of any chemical or equipment to be used. Neither ITER nor any of its agents shall be held responsible for any consequences arising from the application of any cleaning process described in this handbook unless it is under their direct control.

13.4. Proprietary Items and Trademarks

Where propriety items from particular manufacturers or *suppliers* are mentioned in this specification any or all trademarks are duly acknowledged. Manufacturers or contractors are free to suggest alternative items from other manufacturers or *suppliers* provided that they are chemically identical. Any such substitutions need to be *accepted* in writing by ITER.

13.5. Design Rules for Cleanability

At the design stage for a vacuum item, careful consideration should be given as to how the item is to be cleaned. In particular, crevices, blind holes, cracks, trapped volumes, etc., should be avoided as these will act as dirt and liquid traps and it can be very difficult to remove both dirt and cleaning materials such as solvents from such areas. Fortunately, good vacuum practice regarding trapped volumes will also result in a component which is cleanable.

13.6. Initial Inspection and Preparation

Prior to cleaning any item, the following inspection should take place:

1. All vacuum flanges or covers should be removed and the item stripped down as much as is permissible, ideally to single components.
2. All items should be clearly identified by scribing a suitable identification mark on an external surface (never a vacuum surface). This identifier will often be a drawing number with component identifier or some such which is carefully recorded. Alternatively, for items which are either small and are to be exposed to a vacuum, a suitable metal label, preferably of the same material as the component and bearing a scribed identifier may be tied with clean bare wire to the component. If none of this is possible, the items should be stored in a suitable container which is marked with an identifier before and after the cleaning process. After cleaning, these items should be packed in such a way that they will not be re-contaminated by the container.
3. The item should be inspected visually to identify any possible traps, etc. (see 13.5 above) which could affect the vacuum performance of the item, taking into account the specified cleaning process and vacuum regime in which the item is to be used.
4. All vacuum sealing faces should be inspected to ensure that there is no damage to the seal area such as scratches, pitting or other defects. If the seal is of the knife edge type, the knife edge should be carefully examined for damage which could affect the sealing properties.
5. Any adhesive tape attached to surfaces of the item whether or not they are to be exposed to vacuum must be removed and any adhesive residue carefully removed with the solvent isopropyl alcohol or ethanol.

6. Any marker pen or paint or similar on any surfaces of the item whether or not they are to be exposed to vacuum should be carefully removed by scraping if necessary followed by washing with the solvent isopropyl alcohol or ethanol and rinsing in demineralized water.
7. Any threaded holes, etc., whether or not they are to be exposed to vacuum, should be examined to see if there are traces of lubricants, cutting fluids or swarf left inside. Any such should be removed carefully using brushing or blowing out with clean compressed air or nitrogen and/or washing with a suitable solvent followed by rinsing with demineralized water, taking care that no residue is transferred to a vacuum surface.

13.7. Mechanical Processes on Vacuum Surfaces

Abrasive techniques to clean or to attempt to improve the appearance of the surfaces of vacuum components should be kept to an absolute minimum and are preferably avoided. The use of grinding wheels, wire brushes, files, harsh abrasives, sand, shot or dry bead blasting, polishing pastes and the like is prohibited under normal circumstances and certainly without prior *acceptance* by ITER.

Accepted techniques are slurry blasting with alumina or glass beads in a water jet; gentle hand use of a dry fine stone or a fine stone lubricated with isopropyl alcohol or ethanol; hand polishing using fine mesh alumina in an isopropyl alcohol or ethanol carrier on a lint free cloth; hand polishing with ScotchBrite™ (Alumina loaded, Grade A).

If any such surface finish technique is employed, care must be taken that any powder or other residues are removed by copious washing in hot water.

Any other such operations may be carried out only with prior *acceptance*.

13.8. Use of acids

Acid treatment of any sort is to be avoided wherever possible and may only be carried out with specific prior *acceptance* by the ITER Vacuum RO. Most acid treatments are for cosmetic purposes only and may result in degradation of vacuum performance.

Where the use of acids is *accepted*, then exposure of the component must be kept to a minimum and must be followed by copious washing in hot demineralized water.

13.9. Treatment of Weld Burn

One particular use of acid pastes is in the removal of weld burn. In general such burns do not affect vacuum performance and are best left alone. Any scaling (i.e. loose oxides) should be removed using the techniques of Section 13.7.

If it is desired to remove burns, then slurry blasting with alumina in water or hand burnishing with alumina powder is a satisfactory alternative. Heavy abrading, grinding or wire brushing is prohibited. Hand finishing with ScotchBrite™ or a dry stone is also *acceptable*.

13.10. Electropolishing for VQC1 Applications

Electropolishing should only be carried out where it is necessary to produce a smooth surface for reasons of electrical discharge or field emission minimization, emissivity or

similar purposes. It is usually unnecessary from a pure vacuum point of view and indeed can be detrimental to vacuum performance.

Electropolishing should be carried out in clean polishing tanks, using fresh electrolyte.

Local electropolishing can be carried out with tampons. Fresh clean pads dipped in clean electrolyte should be used and excessive pressure should be avoided.

After electropolishing, the item should be washed with copious quantities of hot demineralized water.

If required, vacuum Items for use in Class VQC 1 may be baked to 450 °C for at least 24 hours to remove the residual hydrogen and other contaminants introduced into the surface layers by the electropolishing process.

13.11. Handling and Packing

Handling and packaging of components should be in accordance with the requirements specified in the ITER Vacuum Handbook.

Specifically:

1. Once components have completed initial rough cleaning care should be taken that vacuum surfaces are never touched by bare skin. Powder free latex or nitrile gloves (over cotton or linen if desirable) should always be used when handling components. Colored gloves are not *acceptable*.
2. Once components have started the cleaning process they should complete the cycle without a break. If it is unavoidable that a delay occurs between stages, then care must be exercised that the component is thoroughly dry before storage, and all seal faces and ports must be protected as below. There must never be a break between any chemical cleaning stage and a subsequent water washing stage.
3. After the component has been cleaned and is completely dry, it should be packed carefully to ensure that it remains clean and free from damage. All vacuum sealing faces should be protected with a clean metal plate or a hardboard or similar fibre free board covered with clean aluminium foil held in place by a number of bolts through the fastener holes. Knife edges should be protected with clean metal gaskets (which may have been used previously, but they should be completely free from loose oxide scale). All ports should be covered with strong clean new aluminium foil and plastic covers. Small items should be wrapped in clean aluminium foil and sealed in a polyethylene bag, under dry nitrogen if possible.

Clean conditions for the handling of vacuum components are also defined in the ITER Vacuum Handbook.

13.12. Spray washing

Where an item is cleaned by spray washing, it should be ensured that all hoses, lances, spray heads, etc. are thoroughly cleaned out with clean hot water before the cleaning process starts.

Washing should start at the top of the item and the spray should be worked down to the bottom, ensuring good run-off.

13.13. Standard Cleaning Procedure for Stainless Steel Components

13.13.1. *Preclean*

All debris, such as swarf, should be removed by physical means such as blowing out with a high pressure air line, observing normal safety precautions. Gross contamination, e.g. greases or cutting oils, etc., should be removed by washing, swabbing and rinsing with any non halogenated general purpose solvent. Scrubbing, wire brushing, grinding, filing or other mechanically abrasive methods may not be used (see 13.7 above).

13.13.2. *Wash*

1. The item should be washed down using a high pressure jet of hot town water (at approx. 80°C), using a simple mild alkaline detergent. The detergent should then be switched off and the item rinsed thoroughly with hot water until all visible traces of detergent have been eliminated.
2. If necessary, any scaling or deposited surface films should be removed by stripping with alumina or glass beads in a water jet in a slurry blaster.
3. The item should be washed down with a high pressure hot demineralized water jet (at approx. 80°C), with no detergent, ensuring that any residual beads are washed away. Particular attention should be paid to any trapped areas or crevices.
4. The item should be dried using an air blower with clean dry air, hot if possible.

13.14. Chemical Clean for Stainless Steel for VQC 1 application.

With the addition of the relevant safety precautions, the cleaning process below can also be applied to beryllium,

1. Where possible, the item should be immersed completely in an ultrasonically agitated bath of hot clean liquid solvent for at least 15 minutes, or until the item has reached the temperature of the bath, whichever is longer. The temperature should be the maximum specified by the *supplier* of the solvent.
2. Halogenated solvents are not permitted.
3. Suitable solvents need to be *accepted* by ITER before use. Isopropyl Alcohol, Ethyl Alcohol, Acetone, Axarel 9100™, Citrinox™, P3 Almeco™ P36 or T5161 are *accepted* for this purpose.
4. Where technically feasible, after the liquid immersion stage, the item should be immersed in the vapor of the solvent used for at least 15 minutes, or until the item has reached the temperature of the hot vapor, whichever is longer.
5. It must be ensured that all liquid residues have been drained off, paying particular attention to any trapped areas, blind holes etc.
6. The item is then be washed down with a high pressure hot (approx. 80°C) water jet, using clean demineralized water. Detergent must not be used at this stage.
7. The item is dried in an air oven at approx. 100°C or with an air blower using clean, dry, hot air.
8. If the item is too large to be cleaned by immersion the item may be cleaned by

washing it down with a high pressure jet of P3 Almeco™ P36 or T5161.

9. The item is cooled to room temperature in a dry, dust free area conforming clean conditions as defined in ITER Vacuum Handbook .
10. The item is inspected for signs of contamination, faulty cleaning or damage.
11. The item is baked to a temperature of 300°C or whatever other temperature has been specified for a minimum period of 24 hours at temperature in accordance with the ITER Vacuum Handbook Appendix 15
12. The item is packed and protected as in 13.11 above.

13.15. Chemical Clean for Stainless Steel for use on VQC 2, 3 & 4 components

All items may be cleaned to the specification for items in Class VQC 1

It is also be permissible to use halogenated hydrocarbon solvents for cleaning items in these classes by analogy with 13.13 and 13.14.

For items for Class VQC 2, 3 and 4, baking will not normally be necessary with the exception of items specifically listed in the Vacuum Handbook.

13.16. Chemical Clean for Copper and Copper Alloys

Items manufactured from copper or copper alloys may be cleaned using the procedures for stainless steel, except that in this case Almeco P3-36™ is not acceptable.

Copper surfaces may alternatively be cleaned using a light chromic acid or citric acid etch, followed by thorough washing in hot, clean demineralized water.

13.17. Cleaning Ceramics

Ceramics such as alumina and beryllium oxide may be cleaned using the process described here. Other ceramics may not be able to withstand the high temperature air bake, so manufacturers specifications' must be checked.

Beryllium oxide must in no circumstances be ground or scraped except in specialist facilities.

1. Any surface contamination is removed by wet slurry blasting with alumina powder, or by hand polishing with fine-mesh alumina or diamond powder in an acetone, ethanol or isopropyl alcohol carrier.
2. Components are baked at 1000°C in atmosphere for 24 hours in accordance with Appendix 15. The maximum baking temperature may be limited by the system component materials.
3. Items are wrapped in clean aluminum foil and sealed under dry nitrogen in a sealed polyethylene bag

13.18. Cleaning of Aluminium

1. Components are sprayed with high pressure jets at 60 °C with a 2% solution of Almeco 29™ (an alkaline detergent).
2. This is be repeated with a 2 % solution of Amklene D Forte™.
3. Components are rinsed thoroughly with a jet of hot demineralized water.
4. Components are dried with hot air at 80 °C.

Alternatively,

5. Components are immersed in Sodium Hydroxide (45 g l⁻¹ of solution) at 45 °C for 1 - 2 minutes.
6. Components are rinsed thoroughly in hot demineralized water.
7. Components are immersed in an acid bath containing Nitric acid (50% v/v) and Hydrofluoric acid (3% v/v).
8. Components are rinsed thoroughly in hot demineralized water.
9. Components are dried in warm air.

13.19. Air Baking

Items manufactured from stainless steel and the like may be air baked to provide a low hydrogen outgassing surface.

Note that this procedure is not suitable for materials that form a loose oxide, e.g. copper. Items should be chemically cleaned using the procedures of 13.13 above

Items should then be heated in air at a temperature of 450 °C for a period of 24 hours in accordance with Appendix 15.

13.20. “Snow” Cleaning

A final clean after assembly of components into a large vacuum system may be achieved by the use of “snow” cleaning.

Snow cleaning uses a high velocity stream of soft microscopic particles of solid CO₂ to wash the surface and is effective for removing particulates and some organic contamination from surfaces.

Operatives undertaking this procedure must wear suitable protective clothing and personal safety equipment.

The procedures used will be as specified by the *suppliers* of the equipment.

Snow cleaning will normally only be used for items to Class VQC 1, but may be used on all vacuum components.

13.21. Cleaning Procedures for Vacuum Bellows

13.21.1. General

Great care has to be exercised when cleaning thin walled metal bellows, particularly those of edge-welded, nested construction. If any cleaning residues are trapped between the convolutions, either inside or outside, these can result in corrosion which can rapidly cause leaks to develop. Similarly, if any particulates are deposited in the convolutions, mechanical puncturing can take place. Alkaline degreasing solutions such as Almeco are prone to particulate precipitation and therefore must not be used for bellows assemblies.

13.21.2. Procedure for Bellows for Class VQC 1 use

The bellows must be fixed in an extended position if possible.

1. Any traces of visible, loose contamination are removed with a gentle jet of clean, dry air or nitrogen.
2. The bellows are immersed in an ultrasonically agitated bath of isopropyl alcohol

(IPA) or ethyl alcohol (ethanol).

3. The bellows should be vapor washed immediately in isopropyl alcohol or ethanol vapor.
4. The bellows, including the interspace where appropriate, must be thoroughly dried inside and out using a gentle jet of clean, dry, particulate free air or nitrogen.
5. The bellows should be placed in a dry air oven at 100 °C for at least 1 hour.
6. The bellows should be baked in a vacuum oven, for 24 hours at 250 °C with the bellows interspace pumped.
7. The bellows should be sealed under dry nitrogen in a polyethylene bag.

This procedure can be used for bellows used on VQC 2, 3 & 4 systems with the vacuum bake requirement waived.

13.22. Cleanliness

13.22.1. Wipe Test for Cleanliness

Gross contamination of a vacuum component may be assessed by means of a wipe test. This may be carried out “dry” or “wet”.

Gross contamination may also manifest itself as an “oily” or “solvent-like” smell.

Note that these tests are of a somewhat subjective nature and may not be conclusive and therefore should only be used as a guide to cleanliness and as a marker for subsequent cleaning operations should the tests result in a failure of cleanliness.

13.22.1.1. Dry test

The surface of the component is wiped gently with a clean lint free cloth.

If there is any evidence of a deposit on the cloth (i.e. a stain or a change in color) then the item should be regarded as unclean.

Similarly if the surface of the component which has been wiped shows any evidence of a change in color or reflectivity of light, then the item should be regarded as unclean.

13.22.1.2. “Wet” test

This uses a clean lint free cloth dipped in a solvent which evaporates at room temperature, such as isopropanol, ethanol or acetone.

Appropriate safety precautions against fire hazard, breathing in of solvent fumes, eye and skin protection must be taken.

1. The cloth is dipped in the solvent which is then be allowed to evaporate in a safe manner. There should be no change in the appearance of the surface of the dry cloth.
2. The cloth is dipped in the solvent and the surface of the component is wiped gently while the cloth is still wet.
3. The solvent is allowed to evaporate from the cloth and the surface of the component until they are dry.
4. If there is any evidence of a deposit on the cloth (i.e. a stain or a change in color) then the item should be regarded as unclean.
5. Similarly if the surface of the component which has been wiped shows any

evidence of a change in color or reflectivity of light, then the item should be regarded as unclean.

If required, the deposit on the cloth may be analyzed by a suitable means to determine the chemical nature of the contamination.

13.22.2. *General Test for Cleanliness*

An item shall be deemed to be clean for the purposes of this Appendix provided that it meets the following criteria.

Cleanliness is defined to mean that the concentrations of “contaminants” (i.e. unwanted gas species) in the residual gas spectrum of the item are less than the specified values.

The concentration of a species is defined as the fractional intensity of its measured partial pressure components related to that species defined in a particular way to the total pressure in the system expressed as a percentage.

The partial pressures of species in the vacuum system or related to the component being measured should be obtained using the equipment and procedures defined in Appendix 17 of the Vacuum Handbook.

The residual gas spectrum will have been recorded over 1 –200 amu.

The spectrum will have been corrected for sampling error, mass discrimination and species relative sensitivities.

The definition of “general contaminants” is the sum of the partial pressures of all peaks present in the residual gas spectrum of mass to charge ratio (amu) equal to 39, 41-43 and 45 and above (*excluding* any above 45 specifically listed in the table below). Also to be excluded from this summation are any peaks related to the rare gases xenon (i.e. 132, 129, 131) and krypton (i.e. 84, 86, 83)

Vacuum Class	General Contaminants	Perfluoropolyphenylethers Sum of (peak at 69 and 77 amu)	Chlorinated species (Sum of peaks at 35 and 37 amu)	Comment
VQC 4	5	1	1	Excluding water (sum of 17 and 18 amu) from the total pressure
VQC 3	2	0.5	0.5	
VQC 2	1	0.1	0.1	If unbaked, excluding water as above
VQC 1	0.1	0.01	0.01	After bake

Table 13-1 Allowed concentrations of contaminants pertaining to VQC.

This general test for cleanliness can be carried out as part of the verification of component outgassing in accordance with Appendix 17.

13.23. Definition of Terms

For the purposes of this specification, the words or terms listed in Table 13-2 below are taken to have the stated meanings.

Term	Definition
Contaminant	Any unwanted substance present on a surface
Brushing	Using a fibre glass or wire brush to gently remove loosely adhered matter (e.g. dust) from a surface
Swabbing	Vigorous rubbing with a lint free cloth or rag
Wiping	Gentle rubbing with a lint free cloth or rag, either dry or soaked in a liquid
Washing	Cleaning an item by total immersion in a liquid or by pouring or spraying a liquid over it
Dipping	Immersing an item in a liquid and removing it relatively quickly
Rinsing	Using copious quantities of a liquid to remove traces of a contaminant or other material from an item, usually by repeated dipping or pouring the liquid over the item
Scraping	Using a hand tool of a material harder than the item being scraped to gently remove a thin layer from a surface
Grinding	Using a wheel or stone to remove a substantial amount of material from a surface
Scribing	Marking a surface with a clean metal point, vibrating engraver or laser engraving device, usually for identification or marking out purposes
Sand or shot blasting	Using a stream of abrasive particles e.g. silica or alumina to remove a surface layer. The medium may be a gas or a liquid.
Polishing or burnishing	Using a paste of fine particles, e.g. diamond or alumina, or a dry tool to produce a smooth surface
Solvent	A material which removes a contaminant from an item by dissolving it to form a solution
Detergent	A material which removes a contaminant from an item by acting as a surfactant i.e. by hydrophobic or hydrophilic action. Often used interchangeably (but incorrectly) with the term soap.
Etching	Removing a surface layer by chemical action
Pickling	Stripping of the oxide layer from a surface by use of acids
Passivation	Modifying a surface so that it is left in an inactive state, usually by leaving a uniform oxide film on the surface

Electropolishing	Removal of the surface layers of a metal by immersing the surface in a buffered acid solution and applying an electrical potential.
Ultrasonic cleaning	Immersion of a component in a bath of liquid with ultrasonic agitation
Vapor washing	Immersion of a component in a hot vapor such that the vapor condenses on the item and runs off by gravitation, carrying any contaminant in solution or suspension
Glow discharge	An electrical discharge set up in a low pressure gas. Discharges may use dc or radio frequency potential (voltage) sources
Clean surface	A surface with the desired properties e.g. outgassing.

Table 13-2 Definitions of terms used.

ITER Vacuum Handbook Appendix 14

Guideline (not under Configuration Control)

14. Guide to Passivation & Pickling for Steels and Copper

14.1. Scope of this Appendix

This Appendix specifies typical procedures and processes to be used when materials used for vacuum components for the ITER project need to be passivated.

It is intended that the *suppliers* using such processes should follow the guidance in this Appendix to achieve the requirements of the ITER Vacuum Handbook.

The *supplier* is at liberty to utilise other techniques not described in this Appendix provided that the components supplied comply with the requirements of the ITER Vacuum Handbook.

14.2. General Comments

Pickling is most frequently used to remove heavy scale from steels or a heavy, loose oxide layer from copper (or aluminium).

Pickling is rarely specified for vacuum components, normally only for those to be used in rough vacuum, since the process attacks the metal surface and the oxide layer, tending to leave residues which are difficult to remove.

Heavy scale on steel is best avoided by specifying that the plate produced in a rolling mill or a hot-forged blank is stripped with an air knife while still hot.

Light scale on steel may be removed with a wire brush. Loose oxide on a copper surface can also be brushed off.

Pickling often leaves the surface in an etched state with a matt finish, which may or may not be desirable.

Dimensional stability cannot be guaranteed during the pickling process, so it should normally be carried out on the material before manufacture.

If a vessel assembly is pickled, then final machining of vacuum sealing surfaces must be left until after the pickling/passivation process.

Pickling and passivation must always be followed immediately by an appropriate cleaning process, relevant to the Vacuum Classification of the component. (Refer to Appendix 13)

Pickling should always be followed by passivation. This is best carried out chemically, although native oxide layers can reform on exposure to atmosphere.

It should be noted that thermal outgassing from surfaces which have been pickled/passivated may well be greater than that from a native metal surface and may require additional baking to achieve the outgassing requirements of the ITER Vacuum Handbook.

14.3. Pickling and Passivation of Steels.

Steel manufacturers/suppliers will often have their own preferred method of pickling/passivation and may be unwilling to use any other method. Expert advice from both

a metallurgical and vacuum point of view shall be sought in this case. The vacuum person in this case will be the ITER Vacuum RO.

In no case, however, shall the use of glue in the pickling solution be permitted. Note that the chemicals used in these processes are hazardous and all appropriate safety procedures must be followed.

Table 14-1 below lists some of the acceptable pickling solutions for steels.

Material	Solution	Concentration	Temperature (°C)	Comment
Iron and steel	Sulphuric acid (SG 1.84)	10% solution	50-80	Until Scale visually removed
	Hydrochloric acid (SG 1.19)	10-20% solution	50-80	As above
Stainless steel	Nitric acid (SG 1.4) Hydrofluoric acid (52%)	200gl ⁻¹ 40gl ⁻¹	55-65	As above
	Sulphuric acid (SG 1.84) Hydrofluoric acid (52%) Chromic acid - 60	60gl ⁻¹ 60gl ⁻¹ 60gl ⁻¹	Room	As above
	Hydrochloric acid (SG 1.19) Nitric acid (SG 1.4)	250gl ⁻¹ 22gl ⁻¹	60-70	Bright Finish

Table 14-1 - Pickling solutions for steels.

Unless the pickling/passivation process is carried out on the raw material as part of the production process at the steel mill, the process to be used will typically be as follows:

- ▶ Gross contamination is removed by washing the material in a jet of hot (80°C) water.
- ▶ The material is allowed to dry.
- ▶ The material is thoroughly degreased using one of the methods specified in Appendix 13 of the ITER Vacuum Handbook
- ▶ The pickling baths should be checked visually to ensure that there are no visible signs of contamination, e.g. oils or greases floating on the surface. Ideally, clean pickling solutions in clean baths should be used.
- ▶ The material is lowered into the pickling solution for the specified time or until the process is complete.
- ▶ The material is washed in a jet of hot (80°C) water.
- ▶ The surface of the material is then passivated by lowering into a bath of dilute nitric or citric acid.
- ▶ The material is washed in a jet of hot (80°C) water and allowed to dry.

Note that there are alternative methods of pickling and passivation using spray and gel techniques. The use of such techniques is not prohibited but should only be used following *acceptance* of the proposal by the ITER Vacuum RO.

14.4. Pickling and Passivation of Copper and Copper Alloys

The generalities and procedures of Section 1.3 above apply except where noted otherwise.

Pickling solutions for copper and copper alloys are given in Table 14-2 below:

Material	Solution	Concentration	Temperature (°C)	Comment
Copper and copper alloys	Sulphuric acid (SG 1.84)	20% aqueous solution	65-75	
	Sulphuric acid (SG 1.84)	20% aqueous solution 75gl ⁻¹	20-75	
	Sodium dichromate			
	Citric acid	1% aqueous solution	Ambient	Also passivates the surface

Table 14-2 – Pickling solutions for copper.

Following pickling, copper parts must be passivated immediately by dipping in a 1% aqueous solution of citric acid.

14.5. Standards

The following standard procedures may be used to inform the processes described in this Appendix

- ▶ EN 2516:1997 – Passivation of corrosion resistant steels and decontamination of nickel bas alloys
- ▶ ASTM A380 – Practice for Cleaning, Descaling and Passivation of Stainless Steel Parts, Equipment and Systems
- ▶ ASTM A967 – Specification for Chemical Passivation Treatments for Stainless Steel Parts

ITER Vacuum Handbook Appendix 15

Guideline (not under Configuration Control)

15. Guide for Vacuum Baking of Components

15.1. Scope

This Appendix specifies typical procedures and processes which may be used when vacuum components and materials used for vacuum components for the ITER project are required to be baked.

It is intended that the *suppliers* using such processes should follow the guidance in this Appendix to achieve the requirements of the ITER Vacuum Handbook.

The *supplier* is at liberty to utilise other techniques not described in this Appendix provided that the components supplied comply with the requirements of the ITER Vacuum Handbook.

15.2. General Comments

Vacuum components for the various classifications may require to be baked to ensure satisfactory vacuum performance. Baking can be included as in the component leak testing procedure (Appendix 12) and/or the component cleaning procedure (Appendix 13). A bake temperature and duration will normally be specified in the specification documents and/or drawings for individual components or assemblies. If this is not the case, then the standard temperatures and durations listed in Table 15-1 should be used.

Vacuum baking has three functions, *viz.*, (a) the removal of contaminants which can break down to volatile components under the application of temperature (b) reducing the outgassing rate of the surface by accelerating the thermal desorption of molecular species (most often water) and (c) opening up incipient leaks, particularly porosity, where the leak path has been blocked by, for example, a carbon inclusion.

In order that the objectives of this Appendix are achieved, the times and temperatures specified for vacuum bakes have been based on considerable experience of using the processes.

In the following sections, the term “vacuum item” shall be taken to refer to an individual vacuum component, a sub-assembly or complete assembly as appropriate. It may also refer to material, e.g. steel sheet, being processed prior to manufacture.

Where the temperature is too high for a composite assembly the component part requiring higher temperature baking should be baked at that temperature prior to assembly and then the complete assembly baked at the lowest listed temperature of the component parts. Temperature requirements for baking materials not listed should be *accepted* in advance of baking operations.

Where the manufacturer is unable to carry out a bake procedure, either to the standard conditions in Table 15-1 or as otherwise specified, then any variation shall be *accepted* by ITER before proceeding.

Vacuum Classification	Temperature (°C)	Time (hr)	Comment
VQC 1	240	24	
VQC 1*	350	24	Stainless steel and beryllium
	450 - 2000	24	Carbon composites (see Appendix 16)
	250	24	Precipitation-hardened copper alloys
	350	24	Tungsten

* For vacuum items in line vicinity of plasma.

**Table 15-1 Standard Temperatures and Durations
for Vacuum Baking.**

15.3. General Procedures for Baking of Vacuum Items

15.3.1. Preliminary

Prior to baking, the vacuum item will have been thoroughly cleaned in accordance with the procedure of Appendix 13 of the ITER Vacuum Handbook.

If the vacuum item is not capable of being vacuum sealed and pumped down (e.g. it may be a batch of material or a part-finished vessel), then the vacuum item should be subjected to a total immersion bake (see 15.5.1 below)

All vacuum flanges should be sealed with a blank flange of material and thickness similar to that on the main vacuum item, using gaskets of the type to be used when the vacuum item is in service and fasteners of the appropriate strength.

Where a copper gasket is to be used and the bake temperature is greater than 100°C, then the gasket should be silver plated to avoid the formation of a loose oxide on the atmospheric side of the joint.

The vacuum item should be placed in or on a suitable bakeout stand which can safely support the vacuum item at the maximum temperature of the bake procedure. Any fixings should take into account the thermal expansion of the vacuum item and stand.

The vacuum item should be pumped down to an appropriate vacuum level and thoroughly leak tested to the appropriate specification in accordance with Appendix 12 of the ITER Vacuum Handbook prior to starting any baking process.

15.3.2. Vacuum Pumps and Gauges

Vacuum Pumps of the appropriate pumping speed and base pressure specification should be used in these processes.

Vacuum pumps used for these processes should be inherently clean (e.g. turbomolecular pumps with magnetic or greased bearings, dry backing/roughing pumps, cryosorption pumps or sputter ion pumps). Otherwise, the supplier needs to satisfy ITER that a suitable failsafe trapping system has been implemented to protect against back-streaming and/or pump failure. Vacuum gauges (total and partial) with suitable measurement ranges and with appropriate calibration certificates should be fitted as required to monitor satisfactorily the progress of

the bakeout process.

The manufacturer should provide ITER with complete details of all such equipment (including manufacturer, age, calibration certificates and history).

No bake procedure should be started before ITER has *accepted* the use of this equipment.

ITER will have the right to request documentary proof of the performance of the pumping equipment in the form of blank pump down characteristics and/or residual gas scans of the pumping equipment.

15.3.3. Temperature Monitoring and Control

The manufacturer should implement a suitable system to monitor, control and record the temperature of the baked vacuum item throughout the procedure.

It is important that the rate of rise and fall of temperature is controlled to within the *accepted* specification as detailed in the *accepted* baking procedure. Full details of this system should be supplied to ITER.

No bake procedure may be started before ITER has *accepted* the use of this equipment.

15.3.4. Completing the Bake Process

When the temperature of the vacuum item has fallen to room temperature, the vacuum item should be leak tested thoroughly to the appropriate specification in accordance with Appendix 12 of the ITER Vacuum Handbook.

The vacuum item should be vented to dry nitrogen (dew point -50 °C), removed from the bakeout stand and suitably packed and protected for transport or storage.

15.4. Control of the Bake Process

To avoid undue stress on the vacuum item being baked, the temperature should be controlled such that it is uniform to within ± 20 °C at all points on the surface of the vacuum item, unless otherwise *accepted* by ITER.

The temperature differential across a metal sealed vacuum flange pair of greater than 200 mm diameter should be less than 10 °C at all times.

The rate of rise and fall of the temperature of the vacuum item should be held within specified limits and, unless otherwise *accepted* by ITER, should be no greater than 10 °C per hour.

When the temperature is falling, it is normally permissible to switch off the temperature control when the temperature falls below 50 °C and let the vacuum item cool naturally to room temperature.

Thus for a 200 °C bake, the rise time will normally be 18 hours, the dwell time 24 hours and the fall time 15 hours plus the natural final cooling time.

At no time during the bake process should the pressure within the vacuum item being baked exceed 10^{-3} Pa. If it should approach this level, the temperature must be held until the pressure falls again as the outgassing rate decreases.

The use of a residual gas analyser to monitor the bake process is strongly advised. This can indicate possible leaks opening up during the process. It can also be used for “end point” detection – e.g. when the water peak falls to below a specified partial pressure.

15.5. Types of Bake Procedure

15.5.1. Total Immersion Bake

In this procedure, the vacuum item is totally immersed in the vacuum environment of a vacuum furnace which is capable of reaching the required temperature and maintaining a pressure less than 10^{-3} Pa at the maximum temperature used.

The manufacturer should, before the start of any baking process, demonstrate to ITER, by the provision of residual gas analysis spectra of the furnace during a blank run at the temperature to be used for the bake procedure, that the vacuum level and the cleanliness of the furnace at the temperature at which the bake is to be performed is satisfactory for the purpose. This requirement may be waived by agreement with ITER where the furnace has not been used for any other purpose between two successive bake processes for the ITER organisation.

Any vacuum joints on the vacuum item to be baked shall be left open.

The vacuum item is placed in the furnace, which is sealed and pumped down to the starting pressure with equipment conforming to the requirements of Section 15.3.2 above.

The furnace is checked for leaks.

The appropriate time/temperature bake cycle is carried out.

15.5.2. Oven Bake

The vacuum item, which will be a sealed vacuum vessel or assembly, is placed inside a suitable insulated enclosure and connected by a suitable pumping manifold to a vacuum pumping system conforming to the requirements of Section 15.3.2 above.

The arrangement shall be *accepted* by ITER before use.

Wherever possible, a suitable vacuum gauge or gauges capable of being operated at the maximum temperature of the bake cycle should be attached directly to the vessel or assembly being baked. Pressure readings on these gauges should be scaled to room temperature values by the appropriate temperature correction factor.

The insulated enclosure may be heated by convection heaters, radiant heaters or hot gas. It is recommended that some form of circulation of the air inside the enclosure be used to assist temperature uniformity.

A suitable number of temperature monitors should be fixed to the vacuum item so that the temperature distribution may be adequately monitored to ensure that the appropriate limits are not exceeded (15.4 above).

If any glass or similar viewports or accessories are fitted, they should be covered in triple thickness aluminium foil for thermal protection and fitted with suitable mechanical protection against impact or implosion.

The assembly should be leak tested to the appropriate specification. The appropriate time/temperature bake cycle is carried out.

15.5.3. "Tape" Bake

In this procedure, the sealed vacuum item is wrapped with heater tapes. Rod heaters, heater plates or flange band heaters may also be used.

A suitable number of temperature monitors is fixed to the vacuum item so that the temperature distribution may be adequately monitored to ensure that the appropriate limits

are not exceeded (15.4 above). In this case, it is very important to monitor the temperature on each side of every large (i.e. greater than 200mm diameter) flange pair. Temperature measurement sensors will normally be located close to the heating device (i.e. in the location of highest expected temperature)

Wherever possible a suitable vacuum gauge or gauges capable of being operated at the maximum temperature of the bake cycle are attached directly to the vessel or assembly being baked. Pressure readings on these gauges should be scaled to room temperature values by the appropriate temperature correction factor.

The vacuum item is connected by a suitable pumping manifold to a vacuum pumping system conforming to the requirements of Section 15.3.2 above.

The assembly shall be leak tested to the appropriate specification in accordance with Appendix 12 of the ITER Vacuum Handbook.

The vacuum item may then be wrapped in aluminium foil to assist in uniformity of the temperature distribution, taking care around electrical connections.

If there are glass or similar viewports or accessories fitted, they must be covered in triple thickness aluminium foil for thermal protection and fitted with suitable mechanical protection against impact or implosion.

The vacuum item is then covered with suitable thermal insulation, preferably a ceramic fibre filled flexible jacket or blanket.

The appropriate time/temperature bake cycle is carried out.

15.5.4. Air Bake

Where an air bake is specified for any item, the general procedures are as specified in this Appendix for the particular type of bake (Immersion, Oven or Tape) except that in this case all sections referring to pumping are ignored and all surfaces (interior and exterior) of the item shall be exposed to normal atmospheric air during the bake process.

Vacuum equipment conforming to the above requirements may still be required where a leak test and/or outgassing test has been specified as part of the bake process either before or after such a process.

15.6. Documentation to be Supplied

For each vacuum item, the following certificates and records will normally be supplied:

If requested by ITER a record of the performance of the pumping equipment

- ▶ A certificate of the initial leak rate
- ▶ A certificate of the final leak rate
- ▶ A record of the temperature distribution for the item and pressure within the vacuum item against time for the full duration of the bakeout process
- ▶ If agreed between the manufacturer and ITER, a full record of any residual gas scans taken with appropriate time markers which identify the scans to the position on the component bakeout cycle
- ▶ Full documentation regarding any leaks or other problems which occurred during the tests and any remedial action taken

ITER Vacuum Handbook Appendix 16

Guideline (not under Configuration Control)

16. Guide to the Conditioning Carbon Composites

16.1. Scope

In order to remove absorbed impurities from graphite or carbon fibre composite materials it may be necessary to vacuum bake the raw material in a suitable vacuum furnace.

This Appendix outlines a process which may be used when graphite and carbon composites which are used on the ITER project are required to be baked.

It is intended that the *suppliers* using such processes should follow the guidance in this Appendix to achieve the requirements of the ITER Vacuum Handbook.

The *supplier* is at liberty to utilise other techniques not described in this Appendix provided that the components supplied comply with the requirements of the ITER Vacuum Handbook.

16.2. Procedures

The supplier shall perform a degassing cycle on components after machining to a procedure *accepted* by the ITER Vacuum Responsible Officer in accordance with Appendix 15 of the ITER Vacuum Handbook.

The temperature of the bakeout cycle will depend on the base pressure achievable in the vacuum furnace.

Leak tests of the vacuum furnace should be carried out in accordance with the ITER Vacuum Handbook.

16.2.1. Procedure for high temperature baking

The preferred outline procedure is as follows.

1. Condition the furnace.
2. Load the component parts.
3. Achieve a vacuum pressure of < 10 Pa.
4. Perform a leak test of the furnace. The acceptance leak rate will normally be $< 10^{-6}$ Pa.m³.s⁻¹
5. Increase the temperature of the furnace to 2000 °C, maintaining the pressure at < 10 Pa
6. Hold at 2000 °C for 24 hours maintaining the pressure at < 10 Pa.
7. Cool under vacuum to 400 °C.
8. Back fill the furnace with pure (UHP grade) Nitrogen to ~30 kPa.
9. Cool to room temperature.
10. Vent the furnace to atmospheric pressure with Nitrogen (zero grade).
11. Package the parts in *accepted* packaging and atmosphere.

16.2.2. Procedure for lower temperature baking

In order to maintain the furnace base pressure $< 10^{-3}$ Pa the baking temperature may be

lowered as follows:

1. Condition the furnace.
2. Load the component parts.
3. Achieve a vacuum of $< 10^{-3}$ Pa.
4. Perform a leak test of the furnace. The acceptance leak rate will normally be $< 10^{-6}$ Pa.m³.s⁻¹
5. Increase the temperature of the furnace to 450 °C, maintaining the pressure $< 10^{-3}$ Pa.
6. Hold at 450 °C for 24 hours maintaining the pressure at $< 10^{-3}$ Pa.
7. Cool under vacuum to 400 °C.
8. Back fill the furnace with pure (UHP grade) Nitrogen to ~30 kPa.
9. Cool to room temperature.
10. Vent the furnace to atmospheric pressure with Nitrogen (zero grade).
11. Package the parts in *accepted* packaging and atmosphere.

TER Vacuum Handbook Appendix 17

Guideline (not under Configuration Control)

17. Guide to Outgassing Rates and their Measurement

17.1. Scope

This Appendix is intended as a guide to the measurement of the total and partial thermal outgassing rates of materials, vacuum vessels, components and assemblies for the requirements of the ITER Project. It is intended that the guide be used to assist suppliers in producing outgassing test procedures to comply with the mandatory requirements of the ITER Vacuum Handbook. It also gives details on how the outgassing requirements for ITER systems have been derived.

It is envisaged that outgassing tests will normally be performed on components, parts of the component or “coupons” which have been subjected to the complete manufacturing process. Manufacturing operations which have been applied, including baking and cleaning operations, should be recorded and traceable to the coupon (where used) or to the manufactured component.

17.2. Limitations

This Appendix describes a set of procedures for the measurement of thermal outgassing from a vacuum item when used as part of the vacuum quality assurance procedures for the ITER Project. This Appendix describes the recommended procedures of the most widely used methods of measuring the outgassing rates; it does not consider all available methods. Despite this limitation, the techniques are more widely applicable and form a basis for more general good practice.

The supplier is at liberty to propose other methods of thermal outgassing measurement not described in this Appendix.

When this set of procedures is used to measure the outgassing from a component or coupon placed within a vacuum chamber, the outgassing of the chamber walls cannot usually be neglected and must be subtracted from the measured value to obtain that from the coupon. For this, an independent measurement of the wall outgassing from the empty chamber will be required – often referred to as a blank run.

Unless otherwise specifically indicated, outgassing measurements using these procedures will be carried out with the component under test at 100 °C.

In these procedures the term outgassing shall be taken to mean thermal outgassing unless otherwise indicated.

The methods of measuring outgassing rates described in these procedures yield an average value of the outgassing rate for each surface exposed to the vacuum measurement system.

17.3. Specific Outgassing Rate

Outgassing is described in terms of the rate of desorption of gas from a vacuum surface.

The measured (or net) outgassing rate is the difference between the intrinsic outgassing rate (of the component) and the rate of re-adsorption on the surfaces of the test chamber.

The specific outgassing rate defined as the total gas load generated per unit time due to gas desorbing from a vacuum surface due to the temperature of the surface per unit area of desorbing surface. It is represented here by q_{th} . Units are Pa.m³s⁻¹m⁻².

Clearly,

$$Q_{th} = q_{th} \cdot A$$

Where

Q_{th} is the total outgassing rate (Pa.m³.s⁻¹)

A is the area of the desorbing surface (m²)

17.4. Generic Methods of Measuring Outgassing Rates

17.4.1. Rate of Rise of Pressure Method

This method of measuring outgassing rates is in principle very simple, but there are a number of considerations that need to be taken into account if the measurements are to be meaningful.

The principle of the method is that if one has a volume evacuated to a given pressure p_0 and then isolated from the vacuum pump, the specific thermal outgassing rate q_{th} is given by

$$q_{th} = \frac{V}{A} \cdot \frac{(p_t - p_0)}{t}$$

where

V is the containing vessel volume

A is the total internal surface area of the desorbing surface

p_t is the pressure after a time interval t

provided that the outgassing rate is reasonably constant with both pressure (over the range $p_t \rightarrow p_0$) and the time interval t and that the temperature of the outgassing surfaces is constant.

Partial (i.e. species dependent) outgassing rates may be determined by using a calibrated gas analyser to measure the rate of rise of the partial pressure of a particular species.

What is actually measured using the rate of rise technique when the pressure remains in the high vacuum region or below, is the increase in number density of gas molecules entering the measurement volume of the “pressure” sensor. This increase can be affected by various processes, which can be classified as being either gas sources or gas sinks. A gas source is something which releases gas molecules into the interior of the vessel, and hence eventually into the measurement volume. A gas sink is something which adsorbs or absorbs a gas molecule which strikes it, i.e. it acts as a pump. This is further discussed later.

This method is quite simple to implement and requires the minimum of equipment. Since, during the measurement time the vacuum pump is valved off, there is no need to know the

pumping speed (especially where the speed may be species dependent). Only one vacuum gauge is required. For absolute measurements, the gauge needs to be calibrated for the outgassing species. Where only relative measurements of outgassing are required (e.g. before and after a process such as baking), provided the gauge is known to be reasonably stable in sensitivity, calibration may not be required.

No vacuum parameters of the system need to be calculated or measured, apart from the pressure.

This method works best for relatively low outgassing rates, where measurements can be taken over a long time period. For high outgassing rates, the rise in pressure can be quite rapid, making time and/or pressure dependent measurements difficult.

The volume of the vessel (and all appendages) needs to be measured or calculated to a reasonable degree of accuracy.

This method is more suitable for the measurement of outgassing from vessels or assemblies rather than coupon samples, unless either the intrinsic outgassing rate of the coupon is very much higher than that of the containing vessel or the surface area of the sample is much higher than that of the vessel or both.

17.4.2. *Dynamic Flow (Conductance) Method*

In this method, the item being measured is pumped through a known conductance and the pressure difference across this conductance is measured. The specific thermal outgassing rate q_{th} is then given by

$$q_{th} = C \cdot \frac{\Delta p}{A}$$

where:

C is the conductance

Δp is the pressure difference across the conductance

A is the area of the desorbing surface

Partial (i.e. species dependent) outgassing rates may be determined by using calibrated gas analysers to measure the differences in partial pressure of the particular species.

The method is suitable for all but the lowest values of outgassing, since the value of the conductance can be chosen to give a sensible pressure difference. Variation in outgassing rate with time can readily be measured even when the outgassing rate is quite high or is varying relatively rapidly and the volume of the vessel is not required.

The method requires two vacuum gauges which must both be calibrated for the desorbing species for the most accurate results. Both must remain stable across the full range of measurement for the duration of the test. If partial outgassing rates are required, then two calibrated residual gas analysers (RGAs) should be fitted.

It requires the use of a pump whose speed is much larger than the conductance for all gas species.

The conductance, which is gas species dependent, must be measured or calculated to a

reasonable degree of accuracy.

When measuring outgassing from coupon samples, the outgassing rate of the containment vessel must remain sufficiently stable for a blank run to yield a meaningful correction.

17.4.3. Variant Dynamic Flow Methods

One variant of this method assumes that the pressure on the pump side of the conductance is very much less than that on the sample side and so can be ignored. In this case only one calibrated gauge and one RGA is required, both situated upstream of the conductance. Good practice would require a total pressure gauge also to be fitted downstream of the conductance to ensure that the pressure conditions were being met, but this gauge need not be calibrated.

A second variant uses an arrangement of valves so that a single calibrated gauge can alternatively be exposed to either side of the conductance. This requires good linearity in the gauge and an outgassing rate which is stable over the time of measurement.

17.4.4. Weight Loss Method

The method of weight loss measurement can be used to measure outgassing rates from materials with high outgassing rates, for example organic materials.

The test consists of measuring the weight loss of a sample which has been subject to a defined thermal cycle under vacuum. The sample is placed in an effusion cell and heated. The outgassing flux is condensed on temperature controlled collectors which are placed in front of the sample. From the mass deposit on the collector the total mass loss (TML) and hence outgassing rate are derived, as function of time, and is usually expressed as %TML

The setup and procedure are described in the ASTM E595-93 standard and are widely used in characterisation of materials for use in space applications.

17.5. Sources of Errors in Measuring Outgassing

All methods of measuring outgassing are susceptible to errors which may yield misleading results. Detailed consideration should always be given to this.

17.5.1. System Effects

17.5.1.1. Vacuum Vessels and Conductance's

Either the internal volume of the outgassing measurement chamber, or the conductance between this and the pump, must be known to a reasonable degree of accuracy, dependent on the technique employed. Volumes are notoriously difficult to measure or calculate to high accuracies and are temperature dependent. In some cases (e.g. where bellows are present) they may also be dependent on the atmospheric pressure in the laboratory. Volumes will change if there are movable items present, e.g. vacuum valves.

The value of a conductance element is also temperature dependent and, more importantly, dependent on the mass of the gas species traversing the conductance. To some extent the transmission probability of gas molecules through a conductance is dependent on the size and shape of the vacuum chamber at each end.

It is usually assumed that in measuring outgassing, free molecular flow conditions prevail. This may or may not be the case and needs to be checked.

In the dynamic flow method, it is assumed that outgassing of the vacuum system downstream of the conductance does not influence what is happening in the measurement chamber upstream of the conductance.

17.5.1.2. Vacuum Gauges

The calibration of both total pressure and partial pressure gauges is non trivial and the stability of many gauges is not good. Clearly this may introduce significant measurement errors, especially in the two-gauge dynamic flow method.

17.5.1.3. Vacuum Pumps

Pumping speeds of vacuum pumps vary with the species being pumped, so for the dynamic flow method it is important to ensure that a sufficiently high pumping speed (i.e. compared to the conductance for the particular gas species) is maintained at all times.

17.5.1.4. Temperature

Some of the effects of temperature have been discussed above. However, outgassing is itself strongly dependent on temperature, so it is important that for the most accurate measurements, the entire apparatus is maintained at a constant temperature during the period in which measurements are being taken.

17.5.2. Gas Sources and Sinks

Errors in measured outgassing rates may be affected by sources of gas other than true outgassing entering the measuring volume of the gauge or gauges used. In this case an enhanced value will be measured. Likewise any pumping in the vessel for which outgassing is being measured will lead to an apparent value being measured which is lower than the true value. In extreme cases, negative values of apparent outgassing may be measured.

17.5.2.1. General Types of Gas Source or Sink

Possible sources of gas include:

- any surfaces exposed to the vacuum which release molecules by desorption other than thermal desorption or by permeation
- all joints, which tend to be areas of increased permeation
- leaks, real or virtual
- any gauge
- gas bursts from items moving in the vacuum system

Possible sinks for gas include:

- any surfaces exposed to the vacuum which can exhibit wall pumping, particularly “active” surfaces found in capture pumps even when switched off
- any gauge which can act as a pump

17.5.2.2. Surfaces as Sources

The point of the measurement is to measure thermal desorption from the surface of interest, i.e. gas molecules released by the absorption of phonons, so it is important that extraneous

forms of desorption are minimised. Details are not discussed here, but it should be noted that the surfaces under investigation should not be exposed to significant fluxes of photons of wavelengths shorter than the short-wavelength end of visible or to electrons of energy greater than a few eV. It is also important that the temperature of the surfaces under test is kept constant as thermal desorption is an exponential function of temperature.

For metals at room temperature, permeation is only significant for hydrogen and even that would normally be very low unless very thin walls are present or when measuring very low outgassing rates. However it should be remembered that hydrogen is by far the dominant species in such cases and there is some debate as to whether hydrogen permeation is in fact the rate limiting step in outgassing from metals. The source of the hydrogen may be either dissolution from the bulk metal or passing from atmosphere on one side of the wall to the other. In practice, both will happen.

Glasses, plastics and elastomers may have quite large permeabilities for hydrogen, helium or water. Care must therefore be exercised when these are exposed to both atmosphere and vacuum.

A special case of thermal outgassing is evaporation or sublimation of the wall material (vapour pressure). For most normal vacuum materials, this is only a problem when measuring extremely low outgassing rates.

17.5.2.3. Surfaces as Sinks

When gas molecules strike a surface, in general they stick. They may stick for a short time before being re-emitted or they may stick for a long time. Here, the former process is ignored although it is important for the thermodynamics of the system. However, the latter process gives rise to the phenomenon known as wall pumping. In some cases this process can be enhanced by preparing a surface which is chemically active and deliberately used as a pump in, for example, a Titanium Sublimation Pump (TSP) or a Non-Evaporable Getter (NEG). A similar effect is seen when a surface is cooled to cryogenic temperatures. In normal circumstances the walls of a vacuum system are sufficiently inert that wall pumping is insignificant. However there are circumstances where this may not be the case. A surface which has been glow discharged will have had its chemistry altered somewhat and until a passivation film, usually an oxide, is formed may exhibit wall pumping. Similarly a surface where the gas concentration has been reduced by photon desorption, electron or ion desorption or high temperature thermal desorption may be sufficiently far from equilibrium to exhibit wall pumping.

It is very difficult to estimate what wall pumping speeds might be in such circumstances.

17.5.2.4. Joints

Vacuum joints can be regions of enhanced permeability, especially demountable joints using elastomer gaskets. However, welds and brazes may also be suspect. If components have been hydrogen brazed, then enhanced hydrogen outgassing may be experienced from all surfaces. Joints which have been welded using the Tungsten Inert Gas (TIG) process may exhibit enhanced outgassing of (usually) argon.

17.5.2.5. Leaks

Naturally, the presence of leaks can vitiate any sensible measurement of outgassing and so thorough leak checking of the test system is a necessity.

17.5.2.6. Moving items

When items move in a vacuum, gas molecules can be desorbed. The most common moving item in an outgassing measurement system will be a vacuum valve. These can generate significant gas bursts when moving. This can be minimised by operating them slowly and by thorough outgassing.

In practice, this is not usually very important in measuring outgassing rates. In the case of rate-of-rise measurements, the system is sealed and static. Any gas generated when the valve is closed at the start of measurement forms part of the base pressure. In the two gauge dynamic flow technique, valve states do not change during the measurement. In the variant of this technique where a single gauge is exposed successively to either side of the conductance to eliminate gauge errors, some care has to be exercised to minimise any such effects.

17.5.2.7. Gauges as Sources

Hot filament gauges are clearly potentially major sources of error in measurements of this type, since they not only run at high temperatures but will also cause local heating of the vacuum system. Enhanced outgassing will be experienced from the gauge and walls.

Cold cathode gauges are better than hot filament gauges in this respect since they operate at room temperature.

Ionisation gauges, hot or cold cathode, are also sources of x-rays, ions and electrons of sufficient energy to cause desorption when they strike surfaces. Cold cathode gauges may also generate energetic neutrals which may themselves cause desorption.

17.5.2.8. Gauges as Pumps

All ionisation gauges will act as pumps. Hot filament Bayard-Alpert Gauges typically exhibit pumping speeds of around 0.1 l.sec⁻¹ but this will normally be swamped by the outgassing.

Cold cathode gauges of the Penning or magnetron (whether inverted or not) type may well exhibit (net) pumping speeds of up to 1 l.sec⁻¹.

17.5.3. Some Practical Considerations

17.5.3.1. Minimising Errors

Clearly if one wishes to measure an outgassing rate, all of the above effects may play a part in introducing errors. Good vacuum practice will help in many cases to vitiate the worst of these. Leak testing should be carried out with a sensitivity of at least an order of magnitude better than the measured total outgassing rate. Permeation (but not of course bulk dissolution) can be reduced by surrounding the measurement chamber with a guard vacuum. Wall pumping may be reduced by waiting or by saturating the surface with an inert gas. This may of course make nonsense of what one is trying to do!

In practice, the bulk of the errors will come from the gauge. A hot cathode gauge should be

mounted on a water-cooled side arm, preferably with a cooled baffle in the gauge throat. It should be well-degassed, and any pressure difference between the gauge and the measurement chamber carefully evaluated. If possible a cold cathode gauge should be used or a gauge specially designed to minimise outgassing.

The gauge head must be mounted out of line of sight of the surfaces being tested and tubulation to the gauge head should have as large a conductance as possible. As is so often the case, such requirements are to some extent contradictory so some compromise is necessary. There is not a lot one can do to eliminate the effects of gauge pumping. Recent developments using stable field ion emitters as the electron source for a Bayard- Alpert gauge may offer a good compromise for measuring low outgassing rates. The temperature effect is eliminated and gauge pumping is relatively low. Energetic electrons and X-rays are still produced however.

The most troublesome effect is gauge pumping. In many cases it is relatively easy to guess what the minimum outgassing rate to be expected from a sample might be. The surface area of the sample should then be such that the expected gas load generated is significantly greater than the gas load pumped by the measuring gauge. If this is not the case, then the measurement is not meaningful.

In some cases, where the measured pressures are within its operating range, a suitable gauge is the spinning rotor gauge. Outgassing from this type of gauge is simply that of its rather small internal surface area and there is no pumping effect. It is best suited to rate of rise measurements.

Because not all sources of error can be eliminated, rate-of-rise measurements, for example, can only set a lower bound for the outgassing rate. It may be possible to estimate an upper bound by guessing the gauge pumping speed. If these two values are reasonably close, then the result may be meaningful. This assessment cannot be done unless a real effect, i.e. a measurable pressure rise, is obtained.

It will be apparent that in the rate of rise method, sufficient time must be allowed for the pressure to rise significantly. Initially after isolating the main pump, there will be a period when the system is not in a steady state as the various gas sources and sinks settle down, but in a well-behaved and well designed experiment, this should be relatively short and for a constant outgassing rate a log-log plot of pressure against time should yield a straight line of positive slope. For outgassing rates close to the pumping speed of the system sensible measurement times may well be of the order of hours, not minutes.

17.5.3.2. Time Zero for outgassing

As noted earlier, the outgassing rate measured is a function of the time that a surface has been exposed to vacuum (i.e. has been pumped), and an idealised characteristic is shown in Figure 17.5.3-1 (Note that no great significance should be attached to the actual values of outgassing rate shown in the figure.) It is clear that the measured value of outgassing will depend on when the measurement is made.

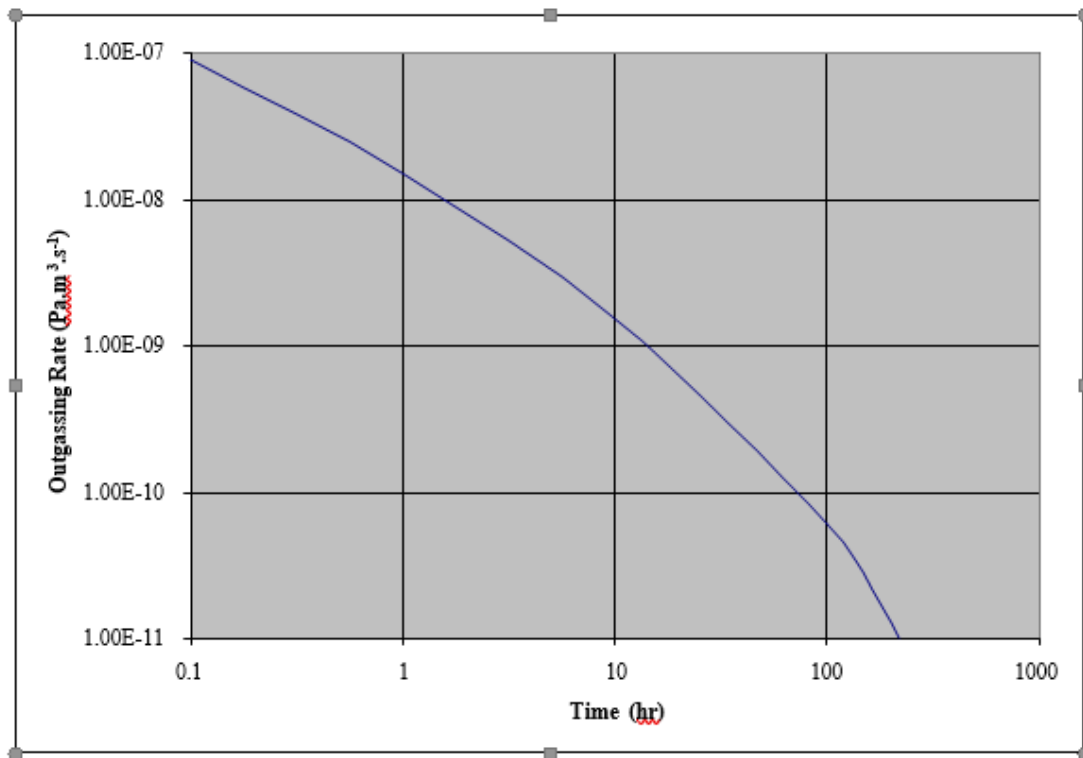

Figure 17.5.3-1 Idealised outgassing rate of a surface as a function of exposure time to vacuum.

Because of the above, in order to achieve some sort of comparability, outgassing rates are often quoted as either 1 hour, 10 hour, 100 hour or “long term” rates. These are rates measured at these time intervals after time = 0. One matter of particular difficulty is determining just when time = 0 actually is. In a pump down, for example, when is the pressure determined by outgassing rather than removal of gas from the volume?

Since this set of procedures is intended for use in a quality assurance environment, this difficulty can be circumvented by careful specification of what should be done in individual cases.

17.5.4. Stating Outgassing Requirements

17.5.4.1. Vessel or Component Acceptance Tests

In the specification for the vacuum item, if an outgassing test is required, then the specification should state the requirement in one of three alternative forms. These are as follows:

“x hours after the end of the procedure y, the specific outgassing rate shall be less than a value of z Pa.m³.sec⁻¹.m⁻² using the measurement techniques described in the ITER Vacuum Handbook Appendix 17.”

or

“m hours after the end of the procedure n, the total outgassing rate shall be less than a value of r Pa.m³.sec⁻¹ using the measurement techniques described in the ITER Vacuum Handbook Appendix 17.”

or

“k hours after the end of procedure g, the steady state specific outgassing rate shall be less than

a value of s Pa.m³.sec⁻¹.m⁻² using the measurement techniques described in the ITER Vacuum Handbook Appendix 17”.

The steady state outgassing rate is defined as the outgassing rate at the time when the rate of change of measured outgassing rate is less than 5 % over an elapsed time of 120 minutes.

That is to say:

$$\frac{q_t - \underline{q}_{(t)}}{+120)} \leq 0.05$$

$$\underline{q}_{(t+120)}$$

$q_{(t)}$ = specific outgassing rate at time t (minutes).

Procedures y, n and g will have been defined earlier in the specification and, unless there are good reasons otherwise, x and m will normally be 10 hours.

17.5.4.2. Testing items, materials for acceptability procedures

Such tests are of a more generic nature and so some standardisation of results is necessary. There are two particular cases to be considered (a) where there is no form of processing and (b) where there is a processing stage included e.g. a bake.

Where no processing is involved outgassing measurements should be taken at intervals of 1 hour, 10 hours and (optionally) 100 hours after the start of pump down of the vacuum item. It should be noted that such results may be influenced by the pumping speed applied, so this should always be quoted.

Following a process stage, outgassing measurements should be taken at intervals of 1 hour, 10 hours and (optionally) 100 hours after the end of the process. In the case of bakeout, the end of the process may be defined as when the system returns to room temperature, unless a particular specification states otherwise. It should be noted that results may be influenced by the pumping speed applied, so this should always be quoted.

17.6. Procedures

17.6.1. General

17.6.1.1. Start Time

In the following procedures, it is assumed that the appropriate starting time for measurements has been set according to the considerations discussed earlier. This is referred to below simply as the start time.

17.6.1.2. Pump Set Conditioning

Before the start time, all pump sets will have been conditioned and proved to be leak tight and clean.

17.6.1.3. Vacuum Vessel Outgassing Measurements

The vessel should be assembled into the appropriate apparatus using flanges and gaskets

appropriate to the vacuum regime for which the vessel is designed.

In the case of the measurement of outgassing of a vacuum chamber whilst being pumped from atmospheric pressure, a preliminary pump down should be made and the vessel and its appendages proved leak tight. Following this leak test, the vessel should be vented to either clean dry nitrogen (dew point $< -50^{\circ}\text{C}$) or normal atmosphere as specified in the test documentation. If nothing is so specified, then clean dry nitrogen is recommended.

In the (usually rare) circumstances of an outgassing measurement being required for a vessel in “as received” condition, then leak tests should be carried prior to the completion of the outgassing measurements to ensure that the results are not dominated by any leak being present. Clearly, great care must be taken during assembly to minimise the possibility of such leaks. If such a leak is detected, the originator of the request for test must be consulted before any further work is carried out.

17.6.1.4. Vacuum Component or Sample Outgassing Measurements

The component or sample should be inserted into a vacuum chamber for which the outgassing characteristics have been established in a blank run immediately prior to the tests.

For a meaningful measurement of outgassing, the expected outgassing load of the component or sample must be at least 10 times greater than that of the empty chamber.

The procedure to be followed will be the same as that for a vessel as specified in the request for test.

17.6.2. Rate of Pressure Rise Method

17.6.2.1. Equipment

The equipment used will typically take the form shown in Figure 17.6.2-1.

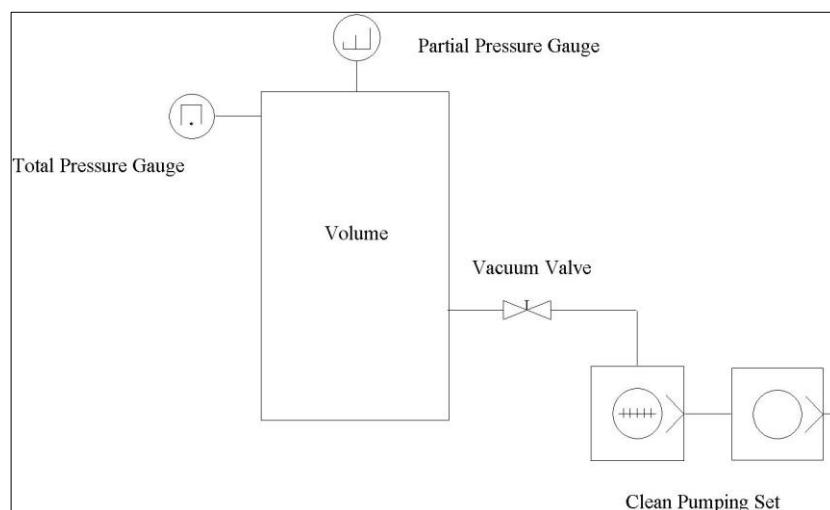

Figure 17.6.2-1 of outgassing - pressure rise technique.

The choice of pumping set and the type of total pressure gauge to be used will depend on the

maximum total pressure expected during the measurements. The gauge is shown as a cold cathode device, but need not be. There are distinct advantages to using a Spinning Rotor Gauge if the pressures measured lie within its range of operation.

The use of a partial pressure gauge will normally mean that the total pressure should not normally rise above about 10^{-3} Pa during measurements unless some sort of sampling stage is used. The pump set should be chosen so that the volume may be evacuated through the valve to a reasonable pressure in a reasonable time. What “reasonable” means must be assessed on a case-by-case basis, but must be short compared to the time at which the first outgassing result is required.

17.6.2.2. Procedure

With the pump set under vacuum at or close to its ultimate, the vacuum valve is opened carefully and the volume evacuated to its base pressure or for the time at which an outgassing measurement is required, whichever is less.

Any processes specified (e.g. a bake cycle) are completed.

If the pressure achieved is below about 10^{-6} Pa, then any hot filament measuring devices should be thoroughly outgassed and the outgassing products pumped away.

The vacuum valve is closed and the pressure or partial pressure of the species of interest recorded at frequent intervals until a pressure rise of at least one decade is obtained. The times of recording each pressure should be noted. The use of a continuous record as on a chart recorder or a data logger is to be preferred.

If outgassing measurements are required at a number of values of pumping time, then the valve should be opened and the process repeated at the appropriate time.

The outgassing rate(s) are then calculated using the above formula.

17.6.3. *Dynamic Flow Method*

Note that only the two-gauge method is described here.

17.6.3.1. Equipment

The equipment used will typically take either of the forms shown in Figure 17.6.3-1. That on the left is more suited to measurements on vessels or assemblies, that on the right to coupon samples.

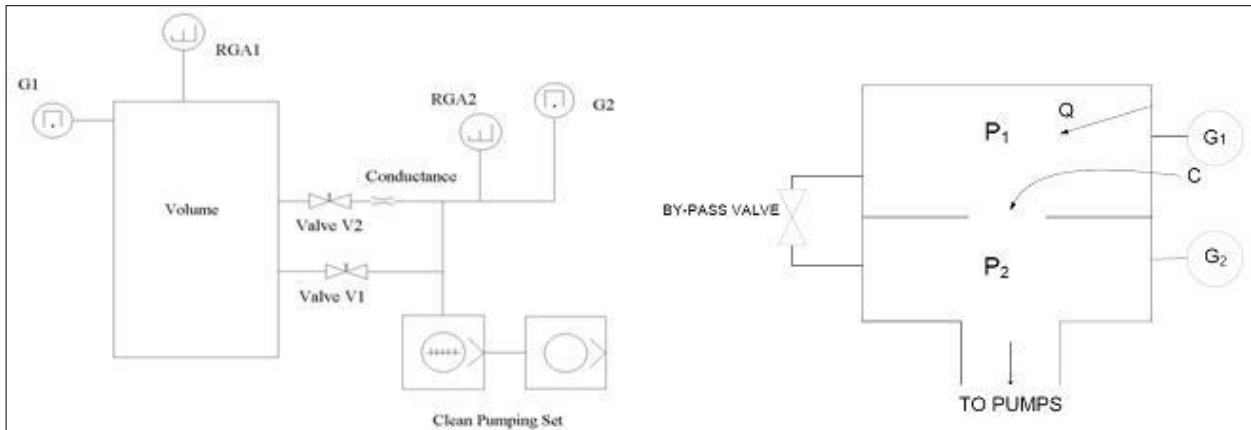

Figure 17.6.3-1 Equipment for the measurement of outgassing - dynamic flow technique.

The choice of pumping set and the types of total pressure gauges to be used will depend on the maximum total pressure expected during the measurements. The gauges shown are cold cathode devices, but need not be. The use of partial pressure gauges will normally mean that the total pressure should not normally rise above about 10^{-3} Pa at the gauge during measurements, unless some sort of sampling stage is used. The pump set should be chosen so that the volume may be evacuated to a reasonable pressure in a reasonable time. What “reasonable” means must be assessed on a case-by-case basis, but must be short compared to the time at which the first outgassing result is required.

The value of the conductance should be chosen so that a reasonable pressure differential is obtained.

17.6.3.2. Procedures

17.6.3.2.1. Outgassing measurements on a vessel

Here, the equipment shown on the left of Figure 17.6.3-1 is the more suitable.

With the pump set under vacuum at or near its ultimate, vacuum valves V1 and V2 are opened carefully and the volume evacuated to its base pressure or for the time at which an outgassing measurement is required, whichever is less.

Any processes specified (e.g. a bake cycle) are completed.

If the pressure achieved is below about 10^{-6} Pa, then any hot filament measuring devices should be thoroughly outgassed and the outgassing products pumped away.

The vacuum valve V1 is closed and the pressures on either side of the conductance monitored until the values have stabilised over a period of about 15 minutes.

If quasi-continuous measurements of outgassing as a function of time are required, then sets of readings shall be taken at appropriate time intervals.

If outgassing measurements are required at a number of discrete values of pumping time, then the valve V1 is opened after a set of readings is complete and closed shortly before the next set is due, allowing sufficient time for the system to stabilise before each set of readings.

The outgassing rate(s) are then be calculated using the formula above.

17.6.3.2.2. *Outgassing measurements on coupon samples*

In this case, the equipment shown on the right of Figure 17.6.3-1 is the more suitable.

To be meaningful, the following procedure should be carried out first with the upper (test) chamber empty, then vented to clean, dry (dew point <-50oC) nitrogen and the sample inserted. The sequence is then repeated, the sample removed and, ideally, a final sequence carried out on the empty system. The two blank (i.e. empty chamber) runs should give consistent results. The measured pressure in the upper chamber with the sample inserted must be significantly higher than the blank runs if a meaningful value of outgassing is to be calculated.

With the pump set under vacuum at or near its ultimate, the valve to the pumping set (not shown) and the by-pass valve are opened and the volume evacuated to its base pressure or for the time at which an outgassing measurement is required, whichever is less. The by-pass valve should be of sufficient size that adequate pumping speed is achieved above the conductance.

Any processes specified (e.g. a bake cycle) are completed.

If the pressure achieved is below about 10^{-6} Pa, then any hot filament measuring devices should be thoroughly outgassed and the outgassing products pumped away.

The by-pass valve should be closed and the pressures on either side of the conductance monitored until the values have stabilised over a period of about 15 minutes.

If quasi-continuous measurements of outgassing as a function of time are required, then sets of readings should be taken at appropriate time intervals.

If outgassing measurements are required at a number of discrete values of pumping time, then the by-pass valve should be opened after a set of readings is complete and closed shortly before the next set is due, allowing sufficient time for the system to stabilise before each set of readings.

The outgassing rate(s) are then calculated using the formula above.

17.7. **Presentation of Results**

On completion of outgassing tests a report should be issued recording:

- full details of the apparatus used (including volumes where appropriate)
- copies of calibration certificates for all gauges used
- details of the calculation of the value of the conductance (where appropriate)
- results of system leak tests
- proof of cleanliness of the pump set
- tabulated measurements of pressure with times at which readings were taken or copies of recorder traces as appropriate
- tabulated values of calculated total and partial outgassing rates as appropriate

17.8. **Derivation of the ITER Outgassing Rate Requirements**

The limits of outgassing rates for materials for use in ITER vacuum systems are given Table 17.8-1, which is Table 5-1 of the ITER Vacuum Handbook and the values are therefore mandatory.

These limits have been produced by taking into account the total surface area expected, available pumping speed, the desired pressure, and post assembly conditioning time, with due consideration of what is reasonably achievable.

		Maximum steady state Outgassing rate Pa.m ³ .s ⁻¹ .m ⁻²		
VQC+	Outgas temperature °C	Hydrogen isotopes	Impurities	Testing Guidelines
1	100‡	1 x 10 ⁻⁷	1 x 10 ⁻⁹	Appendix 17
2	20	1 x 10 ⁻⁷ *		Appendix 17
3	20	1 x 10 ⁻⁸		Appendix 17
4	20	1 x 10 ⁻⁷		Published data and conformity to clean work plan.

For VQC 2, 3 and 4, the outgassing rate excludes the partial outgassing rate for water and hydrogen.

‡ The outgassing test temperature can be reduced to 20 °C for components which normally operate at cryogenic temperatures.

+ For CFC, refer to the ITER Vacuum Handbook Section 26.7

* In the case of resins for magnets, it is considered that this target outgassing rate will be achievable. However a factor 10 increase will be permitted as an acceptance criterion.

Table 17.8-1 – Outgassing rates pertaining to VQC.

17.8.1. Vacuum Vessel

In calculating the maximum outgassing rates specified for the Vacuum Vessel (VQC 1) the following assumptions and calculations have been used.

The approximate total surface area of vacuum vessel is 20000 m² and is calculated as the sum of the following:

- vacuum vessel+ports ≈ 3000 m²
- port plugs ≈ 4000 m²
- blankets ≈ 5000 m²
- divertor ≈ 2000 m²
- piping ≈ 1000 m²
- in-vessel cabling ≈ 2500 m²
- fixtures and fittings ≈ 2500 m²

The ITER Project Integration Document (PID) specifies the vacuum vessel base pressure to be < 10⁻⁵ Pa for hydrogen and <10⁻⁷ Pa for impurities prior to ITER operations at the operating temperature of 100 °C.

Using a conservative estimate of the vacuum vessel pumping speed of 20 m³.s⁻¹ yields a derived maximum hydrogen throughput of 2 x 10⁻⁴ Pa.m³.s⁻¹

Thus, the maximum allowable outgassing rate of hydrogen prior to pulsing is calculated as,

$$q = \frac{Q}{A} = \frac{2.0 \times 10^{-4}}{20000} = 1 \times 10^{-8} \text{ Pa.m}^3.\underline{\text{s}}^{-1}.\text{m}^{-2}$$

It is expected that a factor 10 decrease in the outgassing rate for hydrogen can be achieved by baking the vessel to 200 °C and hence the maximum outgassing rates for VQC 1 components has been defined in Table 17.8-1 as:

- $1 \times 10^{-7} \text{ Pa.m}^3.\text{s}^{-1}.\text{m}^{-2}$ for hydrogen at 100 °C
- $1 \times 10^{-9} \text{ Pa.m}^3.\text{s}^{-1}.\text{m}^{-2}$ for impurities at 100 °C

17.8.2. Cryostat

The outgassing requirement for VQC2 is derived from the need to manage three areas:-

To be able to pump down the cryostat initially in a reasonable time with limited pumping and conditioning capacity and to achieve a level of vacuum suitable for an insulation vacuum.

To avoid poisoning of the activated charcoal in the reference cryostat cryo-pumps with heavy hydrocarbons.

To ensure that over time, the build up impurities on the cold thermal shields does not adversely affect their emissivity and hence the heat load on the superconducting coils and the cryo-plant. The specified outgassing limit for VQC 2 excludes water because it is considered that it will not be possible during the cryostat construction to avoid surfaces becoming water contaminated. It is the case that for item 3 above water ice is likely to be the dominant issue. However other gasses which are condensable at 80K can also present a similar problem and these can be more difficult to condition once the cryostat is complete. To quantify an acceptable outgassing rate, water is used below, as there is a better database available for the relevant emissivity change. In calculating the maximum outgassing rates specified for the ITER cryostat (VQC 2) the following assumptions and calculations have been used.

Source[27]	A (m ²)[27]	qH ₂ O(Pa.m ³ .s ⁻¹ .m ⁻²)+2	QH ₂ O _{tot} (Pa.m ³ .s ⁻¹)	Pressure in cryostat (H ₂ O,Pa)
Metallic surface	2.5 x 10 ⁴	1 x 10 ⁻⁷	2.5 x 10 ⁻³	5.0 x 10 ⁻⁵
Vacuum facing epoxy	1.3 x 10 ³	1 x 10 ⁻⁵	1.3 x 10 ⁻²	2.6 x 10 ⁻⁴
‡Assumes 50 m ³ s ⁻¹ H ₂ O cryostat pumping speed.[27]				
+Values from Table 17.8-1 & equation Section 17.8.1 after 100 hours.				

Table 17.8-2- Assumed cryostat areas and calculated H₂O outgassing rates.

Using the figures from Table 17.8-1 the calculated partial pressure of water vapour in the cryostat prior to the cool down of the magnets is approximately $2.6 \times 10^{-4} \text{ Pa}$.

The 2007 ITER PID value for partial pressure of H₂O before cool-down is quoted as $\leq 2 \times 10^{-7} \text{ Pa}$. This figure is considered to be unachievable and the basis can not be found.

Assuming the cryostat thermal shield does not cool uniformly, residual water will initially condense on cold spots covering an estimated 10% of the thermal shield surface area with an

equivalent thickness of 0.02 monolayers.

After baking the vacuum vessel and cooling the magnet structures and thermal shields, the remaining source of condensable water will be from the cryostat walls and internal components which are at ambient (or elevated) temperature, having an estimated total surface area of 3000 m².

Assuming a steady state outgassing rate of 1×10^{-7} (H₂O) Pa.m³.s⁻¹.m⁻², the load to the thermal shield remains unchanged for 3 years. Over approximately 8 years a coverage of H₂O of 2000 monolayers (1 μ m thickness) will form on the cryostat-facing thermal shield. The change in emissivity of the thermal shield due to formation of this water layer results in a calculated increase in heat load to the cryo-plant of approximately 50% [28].

The ice crystal size significantly affects the infra-red absorption and consequently the emissivity of a panel: the larger the crystals, the higher is the emissivity; therefore the morphology of the ice formation significantly effects the change in emissivity.

In this estimation, it is assumed that the water forms a uniform layer of ice over the thermal shield with the coverage rate constant over the time period considered. If the coverage rate is not constant, and it is assumed water condenses on the thermal shield in batches as “snow”, the time taken for a similar change in emissivity decreases to approximately 3 years.

The effect on emissivity due to the build up of ice can be seen in Figure 17.8.2-1[28] and the effect on the additional load to the cryo-plant due to water condensing on the cryostat-facing thermal shield is shown in Figure 17.8.2-2[28].

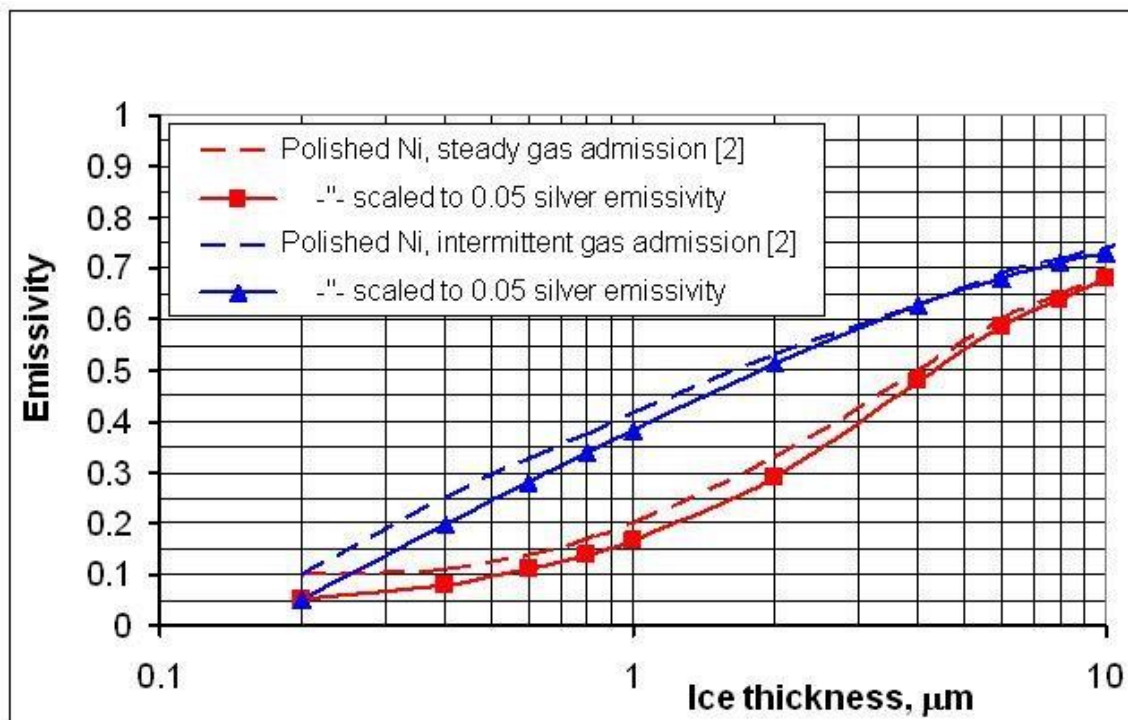

Figure 17.8.2-1 Effect on emissivity due to ice layer formation.

It is considered that the effect on the emissivity of the cryostat thermal shields will be greater due the condensation of hydrocarbons outgassing from the cryostat internal components. Hence the maximum outgassing rate from cryostat vacuum-facing surfaces is defined in Table 17.8-1

to be $1 \times 10^{-7} \text{ Pa}\cdot\text{m}^3\cdot\text{s}^{-1}\cdot\text{m}^{-2}$ (excluding water and hydrogen) at ambient temperature. In order to reduce the steady state outgassing rate of water from the cryostat internal surfaces, a method of purging the cryostat with dry nitrogen prior to cool down of the magnet structures and thermal shields is being studied. The order in which the cryostat cryogenic surfaces are cooled, and the resulting effect on the emissivity of the cryostat cold surfaces due to condensed gas, is also to be studied. (See [28] for further recommendations).

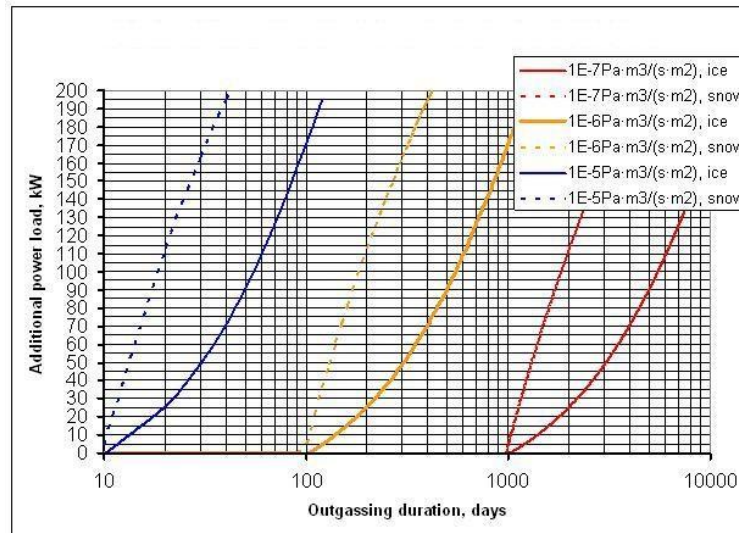

Figure 17.8.2-2 Additional power load on thermal shield coolant due to H₂O Outgassing.

17.9. Outgassing Rates Review

The purpose of this section of the Appendix is to outline the methodology used in the assessment of outgassing rates from published data and to establish the relationship between common parameters which influence material outgassing rates.

17.9.1. Material thermal outgassing

Thermal outgassing from material surfaces is time and temperature dependant and it can be shown that the measured outgassing rate from a metallic surface will increase by factor of about 10 by increasing the sample temperature from ambient to 100 °C, and increases by a further decade by raising the sample temperature from 100 to 250 °C.[5]

The medium term (1 to 100h) outgassing from a surface can be described by a power law of the form:

$$Q = Q_0 \cdot t^{-\alpha}$$

Where, α (the outgassing decay index) is typically near unity for metallic surfaces and 0.5 for epoxies and t is the time in hours [21].

The outgassing rate of a surface is also dependant on the surface condition. Factors affecting the outgassing rate include:

- chemical composition

- the presence of oxide layer's
- surface finishing
- cleaning and other processes

References to published data, listing outgassing rates for materials after varying surface treatments, are to be found in Section 17.10.

While a large record of outgassing rates can be found in literature for vacuum compatible materials comparisons of the reported data are difficult as, in many cases, for the same material differing surface treatments and measurement techniques are reported, some important factors may not be reported at all.

17.9.2. Unbaked Stainless Steel

The rate of outgassing from unbaked stainless steel is dependant of the process to which the stainless steel surface has been subjected. Outgassing rates gathered from literature (see Section 17.10) for Stainless steel after surface treatments are summarised in Table 17.9-1.

SST treatment	q_{tot} (Pa.m ³ .s ⁻¹ .m ⁻²) at 1h, 20°C
As received/fresh	1x10 ⁻⁴
Degreased	2x10 ⁻⁶
Surface finished (machined)	2x10 ⁻⁷

Table 17.9-1 Outgassing rates of stainless steel after surface processing.

Generally water is the dominant species outgassed from unbaked stainless steel and will evolve at a rate dependant on the elapsed pumping time of the surface. Generally, for unbaked stainless steel surfaces, water will remain the dominant outgassing species at pumping times in excess of 100 h.

17.9.3. Baked Stainless Steel

Baking at 150 °C for a minimum of 24 h can reduce the total outgassing rate by a factor of 100 as water is desorbed from the metal surface. After this time the predominant outgassing species from clean stainless steel is hydrogen [5]. A reduction in the hydrogen outgassing rate can be achieved by vacuum firing or air baking the material.

After baking, stainless steel will generally exhibit outgassing rates between 10⁻⁹ and 10⁻¹⁰ Pa.m³.s⁻¹.m⁻² (see Section 17.10.1)

17.9.4. Organic Material

For organic materials (epoxies etc), the method of weight loss measurement is usually used for the determination of outgassing rates with the outgassing rate quoted as a percentage of total weight loss, or gram/s.

Using the formula below the outgassing rate can be calculated from the total mass loss measurement

$$q = \frac{dM}{dt} \cdot \frac{RT}{M} \cdot 10^3$$

where:

q is the outgassing rate in Pa.m³.s⁻¹.m⁻²

R is the universal gas constant (83.14 mbar.l.mol⁻¹.K⁻¹)

dM/dt is the mass loss per unit time (g.s⁻¹)

T is the sample temperature (K)

M is the molecular mass of the outgassing species

Using the above formula it can be shown that for water outgassing from a surface at a rate of 1µg.s⁻¹ the specific outgassing rate near room temperature will be approximately 1 Pa.m³.s⁻¹.m⁻².

The outgassing rate of organic materials is also dependent on the fabrication process (curing temperature, chemical hardener, vacuum, inert gas process, etc.). There is a lack of published data on outgassing rates for material of the same composition which has undergone different fabrication processes, making comparisons difficult. Hence qualification of new organic materials for use on ITER will have to be performed using experimental data.

An analysis of weight loss measurements on epoxies shows that the ratio of water outgassing to impurity outgassing is approximately 100 to 1, so, assuming a well controlled fabrication process, a low outgassing epoxy should outgas at a rate in the range of 10⁻⁷ Pa.m³.s⁻¹.m⁻² (excluding water) after 100 h baking (see Section 17.10.2).

17.10. Outgassing Rates - Published Data

Outgassing rates quoted in referenced publications are summarized in the tables below.

17.10.1. Stainless Steel

Published data on the outgassing rates of stainless steel following various surface treatments is given in Table 17.10-1.

Treatment	Total outgassing rate (Pa.m ³ .s ⁻¹ .m ⁻²)	Time meas. hours)	Reference
None	2x10 ⁻⁴	1h	2
None	2x10 ⁻⁵	10h	2
Polished & vapor degreased	1.4x10 ⁻⁶	10h	2
None	1.1x10 ⁻⁷	100h	2
Degrease + water rinse	4.0x10 ⁻⁸	40h	2
Degrease + water rinse, baked in vacuum 150°C for 12h	4.0x10 ⁻⁹	5h after bakeout	2
Baked 24h @ 200°C	9.3x10 ⁻¹⁰	100h	2

Unbaked	2x10 ⁻⁷	10h	1
Baked (150° C, 24h)	2x10 ⁻⁹		1
Std cleaning	10 ⁻⁶	1h	3
Baked	10 ⁻⁸	1h	3
Untreated	7x10 ⁻⁵		4
Degreased	1x10 ⁻⁶		4
Baked	3x10 ⁻¹⁰		4
unbaked	9x10 ⁻⁷	20h	5
Std cleaning	10 ⁻⁶	1h	3
Baked	10 ⁻⁸	1h	
Electrochemical buffing	5x10 ⁻⁸	50h	8
Electrochemical buffing followed by baking(215 °C,23h) and air (10 days)	1x10 ⁻⁸	50h	8
Electropolished, baked, air oxidation	1x10 ⁻¹¹		9
Air exposure/baking cycles	1x10 ⁻¹⁰		10
UT cleaning + bake 250C,24h	3x10 ⁻¹⁰		12
Various treatments	2x10 ⁻⁶	100h	13
Annealing+bake	2x10 ⁻¹¹		14
Air firing	3x10 ⁻¹¹		15
Pre-baking+baking	4x10 ⁻¹⁰		16
Chemical cleaning	4x10 ⁻⁹		17
	1x10 ⁻⁶	1h	18
Cleaned With bakeout	8x10 ⁻⁷		19
	2x10 ⁻⁹		
	2x10 ⁻⁶	4h	20

Table 17.10-1 Outgassing rates for stainless steel – published data.

17.10.2. Epoxies

Published data on the outgassing rates of various epoxies and resins is given in Table 17.10-2.

Material	Outgassing rate (Pa.m ³ .s ⁻¹ .m ⁻²)	Outgassing rate % Total Mass Loss (TML)	Reference
RF4000 EV Roberts (baked)	5x10 ⁻⁶ (10h)		22
ERL4221 union carbide (baked)	1x10 ⁻⁵ (10h)		
CY179 Ciba Geigy (baked)	3x10 ⁻⁶ (10h)		
1138 Ciba-Geigy (baked)	2x10 ⁻⁶ (10h)		
828 Shell chemical (baked)	1x10 ⁻⁵ (10h)		
DGEBA, + ≠ materials	10 ⁻³ -10 ⁻⁴ (10h)		23
Stycast	4x10 ⁻⁵ (72h)	0.87	24
Redux 312UL	7x10 ⁻⁶ (72h)	0.40	25
Ablebond Ablestik		0.2	ESA database
Araldite resin	10 ⁻³ -10 ⁻⁴ (10h)		1
Polymers	10 ⁻⁵ (10h)		26

Table 17.10-2 Outgassing rates for epoxies and resins - published data.

17.11. References

- [1]P Chiggiato, Outgassing, CAS 2006
- [2]M Wong, review of outgassing rates, Mar 2002
http://home.fnal.gov/~mlwong/outgas_rev.htm#clean
- [3]P Monneau, SDMS, Le dégazage, Dec 1992
- [4]VARIAN, UHV course
- [5]JH Craig, JVSTA vol. 18(3), Apr 1981
- [6]HY Shin, Vacuum vol. 47(6-8), 1996
- [7]M Suemitsu, JVSTA vol. 13(3), May 1992
- [8]Y Saito, vacuum 73 (2004)
- [9]K Okada, Vacuum/vol. 47/1996
- [10]K Okada, JVSTA vol. 5(5), Oct 1987
- [11]JP Bacher, CERN, JVSTA vol. 21(1), Jan 2003
- [12]JD Herbert, JVSTA vol 12(4), Jul 1994
- [13]HF Dylla, JVSTA vol 11(5), Sep 1993
- [14]Y Ishikawa, vacuum 69 (2003)
- [15]V Brisson, Vacuum 60(2001)
- [16]Y Ishikawa, JVSTA vol 9(2), Mar 1991
- [17]KJ Middleman, Vacuum 81(2007)
- [18]A Roth, vacuum technology, third edition
- [19]JM Lafferty, vacuum science and technology

- [20]N Harris, modern vacuum practice
- [21]M Li and HF Dylla, JSTVA vol 12(4), Jul/Aug 1994
- [22]S Rosenblum, JSTVA vol 4(1), Jan/Feb 1886
- [23]S Muralithar, Triumph report, Dec 1986
- [24]OSI report, Nov 2002
- [25]OSI report, Oct 2002
- [26]A Berman ,vacuum calculations
- [27]M Wykes et .al. "Design Status of the ITER cryostat High Vacuum Pumping System"
Proceedings SOFT 24
- [28] A Antipenkov Memo "Thermoshield Icing " IDM Ref. 2E96YC

ITER Vacuum Handbook Appendix 18

Guideline (not under Configuration Control)

18. Vacuum component reliability data

18.1. Scope

This document is a summary compilation of reliability data of vacuum components culled from a variety of sources (See Section 18.2). All failure rate data quoted is average value and is presented as frequency per annum. All mtbf (mean time before failure) values are in years.

By the very nature of such data this summary cannot be fully comprehensive, given the large variety of vacuum components and materials which are available from a diverse number of manufacturers. In addition, although there is a vast quantity of components in use around the world, there is little systematic gathering of data on failure modes and failure rates. One assumes that individual manufacturers collect such data for their own components (and maybe that of their competitors) but little is published and the remainder is generally inaccessible to users.

Anecdotal data, based mainly on experience in the world of accelerators, suggests that an ordered listing of vacuum component failures causing leaks would look something like (worst to best): -

- damaged or improperly made demountable vacuum seals
- edge-welded bellows leaks
- valve seat leaks
- ceramic or glass component shock damage
- ceramic or glass to metal seal failure (corrosion or otherwise)
- brazed coolant feedthrough seal corrosion
- hydroformed or rolled bellows failure
- weld leaks
- metal porosity.

It is difficult to draw systematic conclusions from the data presented, perhaps casting some doubt on its statistical significance.

All data quoted in this appendix is believed to be inherently comparable, coming from the fusion and accelerator communities, where the vacuum atmosphere is relatively non-aggressive, as opposed to the semiconductor industry for example, where chemical corrosion is a major problem.

18.2. Source data

In-Vessel ITER Tubing Failure Rates for Selected Materials and Coolants	T D Marshall and L C. Cadwallader	1994	EGG-FSP-10928	TDM
Selected Component Failure rate values from Fusion Safety Assessment Tasks	L.C. Cadwallader	1998	INEEL/EXT-98-00892	LCC-2
Fusion Component Failure Rate Database	T. Pinna	2001	FUS-TN-SA-SE-R-43 http://spx595.frascati.enea.it:8080/homepage.nsf*	TP-1
Collection and analysis of data related to fusion machines	T. Pinna et al	2005	Fusion Engineering and Design 75-79 (2005) 1199	TP-2
Failure Rate Estimate for Stainless Steel Piping used in ITER Vacuum System	L.C. Cadwallader	2010		LCC-3
Vacuum Bellows, Vacuum Piping, Cryogenic Break and Copper Joint Failure Rate Estimates for ITER Design Use	L.C. Cadwallader	2010	Fusion Engineering and Design 75-79 (2005) 1199	LCC-4

* Page unavailable in Sept 2010

In reality, the information in the paper by Pinna (TP-1) – which is a description of the database rather than digested information contained therein – is very limited and repeats that in LCC-2 so is of little additional value in this context. As noted above, the actual database is no longer accessible at the url cited (or indeed the alternative cited in *Fusion Engineering and Design*, 51-52, November 2000, 579-585).

The data listed in LCC-1 and LCC-2 is derived from a range of operating facilities – fusion machines, accelerators, space simulators and industrial vacuum furnaces. The data in TP-2 derives from experience at JET and TLK. Note that this paper does not cite error factors.

LCC-4 is an attempt to draw together as much relevant data as is available in order to provide a reasonable estimate of the likely reliability of the ITER vacuum system.

18.3. Failure rates for major vacuum components

The following sections provide a digest of the failure rates for major types of vacuum components from the sources cited. The figures will be averages and need to be treated with some care – one would expect there to be some variance between specific models of each type of component, especially when these are available from different manufacturers. This is probably the reason why there is considerable variability in the figures quoted – there is insufficient information cited to clarify this aspect.

For simplicity, values are quoted in two different formats – in terms of failure rates per year and MTBF (mean time before failure) in years. The quoted error factor is a measure of the reliability of the data – the lower the better. This will be related of course in some way to both the number of data points available and their spread. It is not clear how this figure is derived and it is not available for some of the data.

It should be noted that the figures quoted are derived on the assumption that distribution of failures in time follows the “bathtub” curve and that these lie on the part of the curve where failure rates are nearly constant.

18.3.1. Failure rates for vacuum pumps

Type of Pump	Failure mode	Failure rate per year	MTBF (yr)	Error factor	Source
Rough Pumps	Failure to operate	0.13	7.6	1.2	LCC-2
	External leak	5.0×10^{-3}	200.0	10	LCC-2
Turbo Pump	Bearing failure	7.9×10^{-2}	12.7	3	LCC-1
	Housing Leak	5.0×10^{-3}	200.0	10	LCC-1
Cryosorption pump	Housing Leak	5.0×10^{-3}	200.0	10	LCC-1
Cryopumps	Failure to operate	1.8×10^{-2}	57.1	10	LCC-2
	Leak into vacuum chamber	0.18	5.7	1.7	LCC-2
TSP	Filament o/c	1.8×10^{-2}	57.1	1.7	LCC-1
	Feedthrough leak	0.65	1.5	1.4	LCC-1
	Housing Leak	3.0×10^{-5}	33333.3	10	LCC-1
NEG (Cartridge)	Failure to operate	7.9×10^{-3}	126.8		LCC-1
	Housing Leak	3.0×10^{-5}	33333.3	10	LCC-1
Ion Pump	Failure to operate	0.18	5.7	3	LCC-1
	Housing Leak	3.0×10^{-5}	33333.3	10	LCC-1
	Feedthrough leak	13	0.8	1.4	LCC-1

18.3.2. Failure rates for vacuum gauges

Type of gauge	Failure mode	Failure rate per year	MTBF (yr)	Error factor	Source
Rough Vacuum Gauges	Failure to operate	0.88	1.1	10	LCC-2
	Leak	1.0×10^{-3}	1000.0	3	LCC-2
Pirani gauge	Failure to operate	0.26	3.8	10	LCC-1
	Leak	6.0×10^{-3}	166.7	2.2	LCC-1
High Vacuum Gauges	All modes	6.0×10^{-3}	166.7	2.2	LCC-2
Penning gauge	All modes	6.0×10^{-3}	166.7		LCC-1
BAG	All modes	6.0×10^{-3}	166.7	2.2	LCC-1
Not specified	Leak	2.5×10^{-2}	39.4		TP-2

18.3.3. Failure rates for vacuum gate valves

Type (where known)	Failure mode	Failure rate per year	MTBF (yr)	Error factor	Source
	Failure to operate	0.88	1.1	2	LCC-1
	Failure to operate	4.4×10^{-2}	0.0	2	LCC-2
	Failure to operate	9.6×10^{-4}	1037.8		TP-2
	Spurious open or close	2.6×10^{-2}	38.1	10	LCC-2
Motorised	Spurious open or close	4.4×10^{-4}	2283.1	10	LCC-1
Pneumatic	Spurious open or close	2.6×10^{-2}	38.1	10	LCC-1
Solenoid	Spurious open or close	4.4×10^{-3}	228.3	10	LCC-1
	Housing Leak	1.8×10^{-3}	570.8	10	LCC-1
	Housing Leak	1.8×10^{-3}	570.8	10	LCC-2
	Housing Leak	6.6×10^{-3}	152.2		TP-2
	Seat leak	2.6×10^{-2}	38.1	30	LCC-1
	Seat leak	2.6×10^{-2}	38.1	30	LCC-2
	Seat leak	4.6×10^{-2}	21.5		TP-2

Vacuum gate valves can have one of two distinct types of actuator for the seal mechanism. The first uses a shaft sliding through a sealing bush or gland. In the second type, the motion is accommodated by means of a bellows, normally an edge welded bellows. Although it is not clear to which type the data in the table refers, it is most likely to be the latter which are more reliable. Bellows leaks are not specifically identified in the data but probably dominate the statistics quoted for housing leaks.

18.3.4. Failure rates for standard fittings

Group	Type	Failure mode	Failure rate per year	MTBF (yr)	Error factor	Source
Metal gasket flange	160-215mm	Leak	1.0×10^{-3}	1000.0	3	LCC-1
	295-360mm	Leak	6.0×10^{-2}	16.7	3	LCC-1
	>1m	Leak	0.5	2.0	10	LCC-1
	Bolt		1.8×10^{-4}	5707.8	10	LCC-1
Window		Leak	1.2×10^{-2}	81.5	1.8	LCC-1

18.4. Failure rates for bellows

Vacuum bellows are used in vacuum systems to facilitate motion, to take up expansion and contraction and to compensate for construction inaccuracies. There are two major families, *edge welded* bellows which are fabricated from stacks of thin annuli welded alternately on the outer and inner diameters, and *formed* bellows which are rolled or moulded from thin seam welded sheet or thin wall drawn tube. Edge welded bellows are very flexible and can accommodate large extensions and contractions, so are useful for long throw linear motions for example, but are relatively fragile. Formed bellows are more rigid, are less flexible, and are less vulnerable.

Available reliability data does not distinguish between failure rates for these two families, but the data appears to be dominated by formed bellows. The failure rates for edge welded bellows will be inherently higher than those for formed bellows. However, because of the different characteristics of these two types of bellows, it is much more likely that edge welded bellows will be used in motion actuators rather than in the relatively static applications for which formed bellows are more suitable. Lifetimes for edge welded bellows will therefore tend to be dominated by duty cycle rather than mtbf. It may be noted that for edge welded stainless steel bellows, manufacturers will typically quote lifetimes of 10,000 cycles.

LCC-4 provides an extensive discussion of bellows failures based almost entirely on data from LEP at CERN, as is that in LCC-1. The TP-2 data derives from JET. The LCC-1 data is derived from 3 bellows failures during a vacuum bake in the early conditioning phase of LEP and are included in the early service leak data in LCC-4. The values of failure rates from CERN are based on assumptions about the time in service of bellows units which do not appear to take into account duty cycles. This however, would not explain the discrepancies in the values.

Failure data is summarised in the table below.

Type	Failure mode	Failure rate per year	MTBF (yr)	Error factor	Source
Metal Bellows	Leak	70.1	0.14	1,6	LCC-1
	Leak	1.66x10 ⁻²	60.1		TP-2
	Early service leak	7.01x10 ⁻²	14.3		LCC-4
	Small leak (10-8 Pam3s-1)	7.0X10 ⁻⁴	1430		LCC-5
	Large leak	8.8X10 ⁻⁵	11400		LCC-6

Based on the derived operational data from LEP, LCC-4 calculates anticipated lifetimes for the double bellows configuration anticipated for ITER. The values are, for small leaks, a failure

rate of 7×10^{-6} per annum (mtbf 1.4×10^5 yrs) and for large leaks, 8.8×10^{-7} and 1.1×10^{-6} respectively.

18.5. Failure rates for metallic tubing and pipework

Determining failure rates for metallic tubing and pipework is a very complex business since there are many variables to be taken into account. TDM, LCC-3 and LCC-4 go into this in considerable detail for many of the potential situations relevant for ITER.

For the purposes of the Appendix, we shall note that there are three distinct categories of pipe and tubing – those forming a boundary between atmosphere or other gas and vacuum; those immersed in vacuum and containing water as a coolant; those immersed in vacuum and carrying a cryogenic fluid. In all cases, the inherent reliability of the system will most likely be dominated by joints rather than the metal itself.

The data in TDM, LCC-3 and LCC-4 is derived mainly from fission reactor data with pipes carrying liquid coolant, so will be particularly relevant to water coolant lines in ITER. Values for stainless steel pipe type 304L when scaled to ITER conditions are given below. The reliability of vacuum lines will be dominated by joints – seam welds, joining welds/brazes, etc., and should be comparable to any other vacuum envelope.

	Failure rate per year per m
Schedule 20 pipe	1.2×10^{-7}
Schedule 10 pipe	2.4×10^{-7}

It may be of interest to note that the failure rates quoted above for vacuum pump housings for ion pumps, TSPs and NEG pumps which are basically simple stainless steel vacuum vessels of characteristic dimension somewhat less than 1 m, are about two orders of magnitude higher. Whilst it is true that the wall thickness will be less than schedule 10, it is difficult to account for this difference if it is statistically significant.

TDM lists data for a number of different materials. It shows copper water cooling tubing to have failure rates rather more than two orders of magnitude worse than for stainless steel type 316L. It may be relevant to comment here that accelerator experience shows enhanced corrosion rates for copper in the presence of X-ray flux.

18.6. Other References

L.C. Cadwallader and T. Pinna, *Progress Toward a Component Failure Rate Data Bank for Magnetic Fusion Safety*

L.C. Cadwallader, *Failure Rate Data Analysis for High Technology Components*, INL/CON-07-12265

These references discuss methodology rather than providing data.

ITER Vacuum Handbook Appendix 19

Guideline (not under Configuration Control)

19. Documentation and QA for Vacuum Quality Assurance

19.1. Scope of this Appendix

This Appendix describes typical documentation which should normally be produced to assure adherence to the Quality Assessment (QA) system for vacuum items for use in the ITER Project.

Suppliers who follow the guidelines contained in this Appendix will provide suitable documentation which will meet the requirements of the ITER Vacuum Handbook. Other forms of documentation which satisfy these requirements may be *accepted*.

This Appendix does not specify a *Quality Control* System for vacuum items for the ITER Project. This will be specified elsewhere to conform to the necessary international standards.

This document does not specify the technical requirements for, or specifications of, any individual vacuum item. Such information will be found in general form elsewhere in the ITER Vacuum Handbook and in detail in the specification and/or drawings issued by ITER for any particular tender or contract.

In any dispute over QA related to vacuum procedures applied to or vacuum performance of any item, the decision of the ITER Vacuum Responsible Officer (RO) will normally be taken as authoritative.

19.2. Areas to which Vacuum QA Applies

- ▶ Materials
- ▶ Satisfactory procedures for cleaning and processing
- ▶ Assessment of cleanliness
- ▶ Leak tightness
- ▶ Outgassing performance
- ▶ Baking

19.3. Supplier's QA System

It is to be expected that the *supplier* will have experience in operating a quality assurance system to the relevant national or international standards, e.g. ISO 9001 or equivalent. Evidence of this would normally be supplied with the tender or quotation process.

19.4. Certificates

Except where the ITER Project has issued a specific pro-forma certificate pertaining to any

requirement, the *supplier* should use a suitable certificate of the *supplier's* devising. Draft versions of such certificates should be submitted as part of the tender or quotation process to be *accepted* before use. Certification should conform to EN 10204 2.2, 3.1 or 3.2

19.5. Materials Used

19.5.1. Information Normally Required Prior to Manufacture

- ▶ The *supplier* should supply typical certificates of chemical analysis for each batch of material called in the specifications and/or drawings, based on the *supplier's* previous experience of such materials. If the *supplier* has no previous experience of using such materials, a statement of this fact should be supplied.
- ▶ The *supplier* should normally supply certificates and/or samples of capability of carrying out welding or other jointing techniques called in the specifications and/or drawings for the materials to be used.

19.5.2. Normal Post Manufacture Certification

- ▶ The *supplier* should issue a certificate that all materials used conform to the specification and/or drawings, drawing attention to any discrepancies.
- ▶ Unless otherwise specified, certificates of chemical analysis of each batch of material used (e.g. ladle or ingot samples) are normally required.
- ▶ Forged stainless steels for use on VQC 1A components should be supplied with certificates of inclusion counts conforming to ASTM E-45 method D or equivalent.

19.6. Cleaning and Processing

19.6.1. Information Normally Required Prior to Manufacture

- ▶ The *supplier* should provide details of the cleaning processes to be used in the form of a job flow check sheet or diagram, together with a list of the chemicals used.
- ▶ The *supplier* should provide details of all equipment to be used for cleaning or processing, including sizes, *supplier* and approximate date of manufacture. Details of all vacuum pumps and gauges which may be used in any process are to be included. Where any equipment cannot meet the requirements of the specification this must be clearly indicated.
- ▶ The *supplier* should provide details of any subcontractor to be used for cleaning and/or processing.

19.6.2. Normal Post Manufacture Certification

- ▶ The *supplier* should deliver a certificate for each item supplied showing compliance with the appropriate specification. This will clearly identify the item and record all significant parameters (e.g. time and temperature) of the major stages of the processes applied and all equipment used.

- ▶ A non-conformance report should be provided for each item where any deviation from the *accepted* procedures has occurred.

19.7. Assessment of Cleanliness

19.7.1. Information Normally Required Prior to Manufacture

- ▶ The *supplier* should provide details of the method or methods to be used to assess cleanliness of the items.
- ▶ The *supplier* should provide full details of all equipment to be used for assessing cleanliness including specification, supplier and approximate date of manufacture. Details of all vacuum pumps and gauges to be used in any testing are to be included. Where any equipment cannot meet the requirements of the specification this must be clearly indicated.
- ▶ The *supplier* should provide details of any subcontractor to be used for assessing cleanliness.

19.7.2. Normal Post Manufacture Certification

- ▶ The *supplier* should deliver a certificate for each item supplied showing compliance with the appropriate specification. This will clearly identify the item and all equipment used. Included will be a record of all significant parameters of the major stages of the procedures used to carry out these tests and calibration certificates for vacuum gauges and gas analyzers used. Results of any chemical analyses or residual gas spectra will be supplied in full.
- ▶ A non-conformance report should be provided for each item where any deviation from the performance specification has occurred.

19.8. Leak Tightness

19.8.1. Information Normally Required Prior to Manufacture

- ▶ The *supplier* should provide details of the method or methods to be used to leak test the items in accordance with the ITER Vacuum Handbook.
- ▶ The *supplier* should provide full details of all equipment to be used for leak testing including specification, supplier and approximate date of manufacture. Details of all vacuum pumps and gauges, including dates of calibration, to be used are to be included. Where any equipment cannot meet the requirements of the specification this must be clearly indicated.
- ▶ The *supplier* should provide details of any subcontractor to be used for leak testing

19.8.2. Normal Post Manufacture Certification

- ▶ The *supplier* should deliver a certificate for each item supplied showing compliance with the appropriate specification. This will clearly identify the item and all

equipment used in these tests. Included will be a record of all significant parameters of the major stages of the procedures used and calibration certificates for leak detection equipment and standard leaks used.

- ▶ A non-conformance report should be provided for each item where any deviation from the performance specification has occurred.
- ▶ The *supplier* should report details of all leaks found during the manufacturing phase and details of remedial action taken to minimize the size of any identified leaks.

19.9. Outgassing Performance

19.9.1. Information Normally Required Prior to Manufacture

- ▶ The *supplier* should provide details of the method or methods to be used for measuring outgassing in accordance with the ITER Vacuum handbook Appendix 17, where this is called for in the specification and/or drawings
- ▶ The *supplier* should provide full details of all equipment to be used for measuring outgassing including specification, supplier and approximate date of manufacture. Details of all vacuum pumps and gauges, including dates of calibration, to be used are to be included. Where any equipment cannot meet the requirements of the specification this must be clearly indicated.
- ▶ The *supplier* should provide details of any subcontractor to be used for measuring outgassing.

19.9.2. Normal Post Manufacture Certification

- ▶ The *supplier* should deliver a certificate for each item supplied showing compliance with the appropriate specification. This will clearly identify the item and all equipment used for these measurements. Included will be a record of all significant parameters of the major stages of the procedures used and calibration certificates for vacuum gauges and gas analysers used.
- ▶ A non-conformance report should be provided for each item where any deviation from the performance specification has occurred.

19.10. Baking

19.10.1. Information Normally Required Prior to Manufacture

- ▶ The *supplier* should provide details of the method or methods to be used for Baking in accordance with the ITER Vacuum Handbook where this is called for in the specification and/or drawings
- ▶ The *supplier* should provide full details of all equipment to be used for baking including specification, supplier and approximate date of manufacture. Details of all vacuum pumps and gauges, including dates of calibration, to be used are to be included. Where any equipment cannot meet the requirements of the specification this must be clearly indicated.

- ▶ The *supplier* should provide details of any subcontractor to be used for baking.

19.10.2. Normal Post Manufacture Certification

- ▶ The *supplier* should deliver a certificate for each item supplied showing compliance with the appropriate specification. This will clearly identify the item and all equipment used for these measurements. Included will be a record of all significant parameters of the major stages of the procedures used and calibration certificates for vacuum gauges and gas analysers used.
- ▶ A non-conformance report should be provided for each item where any deviation from the performance specification has occurred.

ITER Vacuum Handbook Appendix 20

Guideline (not under Configuration Control)

20. Standard components

Standard Components **TBD**

Type	Name / type	Applicable to Vacuum Quality Classification							
		1A	1B	2A	2B	3A	3B	4A	4B
Valves Vacuum Fittings	Double bellows VAT series 10	✓	✓	✓	✓	✓	✓	✓	✓
	VCR, <i>all sizes</i>	✓	✓	✓	✓	✓	✓	✓	✓

KEY: ✓ = approved for use. ✗ = not approved for use. † = restricted use

Type	Name / type	Applicable to Vacuum Quality Classification							
		1A	1B	2A	2B	3A	3B	4A	4B

KEY: ✓ = approved for use. ✗ = not approved for use. † = restricted use

ITER Vacuum Handbook Appendix 21

Baseline report (not under Configuration Control)

21. Glossary of vacuum terms

Note that common standard vacuum terms related to gas flow, vacuum pumps or pressure measurement are not included as they may be found in any standard textbook on the subject.

Back-filling	Raising the pressure of a vacuum space by admission of a defined gas.
Baking or bakeout	Heating of a vacuum component to remove adsorbed gas (usually water) from the surface.
Bellows (<i>incorrectly</i> bellow)	A section of a vacuum envelope which permits movement of one part of the vacuum envelope with respect to another part.
Blow hole	A surface hole in a material which has solidified from a liquid and which may join onto a void within the material, especially in a weld melt zone or in a braze fill.
Bonding	In this context, the joining of two materials or vacuum items to form a permanent, leak tight joint.
Brazing	A technique for joining two items by filling the interspace between them with another material, usually an alloy, which melts at a temperature lower than that of the items and which wets the surface of each of the items, filling gaps between workpieces by capillary action.
Clean	A vacuum item is clean when it is in a state such that it emits no undesirable species into the vacuum space or does not adversely affect any desired process in the vacuum.
Clean work plan	A documented set of procedures by means of which a vacuum item shall be transformed into a clean state and by means of which it shall be maintained in that state during all subsequent operations or procedures.
Cleaning	The process of transforming a vacuum item from a contaminated state to a clean state.
Coating	Covering the surface of a material with a conformal layer of another material.
Cold welding	A process by which two clean metal surfaces held in physical contact become permanently bonded without the action of heat.
Component	<i>See</i> Vacuum component
Contaminant	A substance on the surface or in the bulk of a vacuum item which can interfere with any process intended to be carried out on that item or which can desorb to give an undesirable species in the residual gas of the vacuum.
Cross contamination	Where a contaminant present on the surface or in the bulk of one vacuum item is transferred onto or into another vacuum item.

Cryopumping	Removal of a gas from the vacuum space by condensing it onto a cold surface
Cryosorption	Removal of a gas from the vacuum space by adsorbing it onto a cold porous material e.g. charcoal or zeolite.
Cutting fluid	A fluid used for cooling and/or lubricating a cutting device, e.g. a milling head.
CVD (Chemical vapour deposition)	Deposition of a coating onto a substrate by chemical reaction in or from the gas phase, usually at an elevated temperature.
DA	Domestic Agency
Degassing	Removal of gas dissolved in a material, usually by heating the material to a high temperature in a vacuum.
Desorption	The release of a substance from a surface into the vacuum space. (<i>Note: the related verb form is desorb</i>)
Diffusion	In this context, the transmission of gas atoms or molecules from one side of a vacuum barrier to the other by direct migration through the solid or glassy phase or along the grain boundaries of the material.
Diffusion bonding	A technique for joining two items by filling the interspace between them with a material or materials which can diffuse into the surface layers of the host material of each item under the action of heat and/or pressure thereby forming a bond between them.
Dry lubricant	In this context, a solid state material which when deposited between two surfaces in vacuum reduces the coefficient of friction significantly or prevents cold welding. Examples would be MoS ₂ , WS ₂ or WSe ₂ .
Edge welded bellows	Bellows which are formed from a number of thin annuli by welding around the circumference of alternately the inner and outer diameters of the annuli. Such bellows can provide great flexibility longitudinally and significant flexibility in the transverse direction.
Electrical break	A device which permits two parts of the envelope of a vacuum system to operate at different electrical potentials whilst maintaining gas flow continuity between the two parts of the vacuum envelope.
Explosion bonding	A technique for joining two items, usually in the form of sheet metal, by generating a high pressure at the interface by means of an explosion. There will not normally be any filler material between the items.
Feedthrough	A device by means of which electrical potential or current can cross the boundary of a vacuum space or by means of which a pipe carrying a fluid can cross the boundary of a vacuum space.

Formed bellows	Bellows formed from a thin sheet or cylinder of metal in which convolutions are manufactured by rolling or by hydrostatic pressing against a former. Such bellows allow limited flexibility in any direction.
Friction bonding	A technique for joining two dissimilar materials by using friction heating to liquefy the interface.
Full penetration welding	Welding where the heat is applied to one side of a prepared joint such that the melt zone extends through the whole thickness of the material.
Gasket	A mechanical seal that fills the space between two objects.
Getter	A material which acts as a vacuum pump by trapping residual gas atoms by chemically bonding them to the atoms of the getter material or by dissolving them.
Helium bombing	A technique by which a nominally hermetically sealed component is subjected to an overpressure of helium so that, on subsequent exposure of the component to a vacuum, helium desorption into that vacuum indicates that a leak or porosity may be present which allowed helium to enter the component.
Helium leak detection	Using the transmission of helium gas through a leak path from the higher pressure side of a vacuum barrier to the lower pressure side and detecting the passage of the helium by means of a suitable mass sensitive device e.g. a mass spectrometer.
High vacuum (HV)	Pressures between 10^{-3} Pa and 10^{-7} Pa.
Hipping	Material forming by applying a high pressure to a powder at a high temperature but below its melting point so that the particles stick together to form a relatively dense and non-porous solid.
Inclusion	A particle embedded in a material that is chemically or structurally different from the host material.
ITER Vacuum Responsible Officer (RO)	A person nominated by ITER as the arbitrator on matters pertaining to vacuum.
Leak rate	The volumetric flow of gas through a vacuum barrier.
Leak tight	Not exhibiting a leak rate great than the minimum detectable leak.
Liquid dye penetrant	A liquid of low viscosity which is used to penetrate small voids or porosity in a material and which evaporates to leave a coloured dye in the voids thus revealing their presence.
Medium vacuum	Pressures between 0.1 Pa and 10^{-3} Pa.
Minimum detectable leak	Smallest value of leak rate which can be detected by the apparatus being used, usually at a signal to noise ratio of 2.
Outgassing	Gas desorbed from a vacuum surface due to the temperature of the surface. Such gas will normally derive from the surface or immediate sub-surface layers of the material.

Permeation	Diffusion or porosity.
Porosity	Transmission of a gas through a solid due to linked small voids in the solid.
Purge gas	A gas flowing through a vacuum system, usually in turbulent flow mode, so as to remove a contaminant such as water.
PVD (Physical Vapour Deposition)	Deposition of a coating onto a substrate from the gas phase, by a means such as evaporation, sublimation or sputtering.
Residual gas	Those atomic or molecular species contributing to the pressure inside a vacuum envelope.
Residual gas scan	A mass spectrometric analysis of the residual gas in a vacuum space.
Rough vacuum	Pressures between atmosphere and 0.1 Pa.
Scale	Poorly adhered oxide clumps on a metal, particularly steel, caused when the metal cools from high temperature to room temperature in atmosphere e.g. after hot rolling of sheet steel or welding.
Sealing surface or seal face	A surface of a vacuum item which is used to form a leak tight joint by means of a vacuum seal being pressed against it.
Seamless pipe	Pipe (or tube) formed without longitudinal weld
Sintering	Material formed by heating a powder to a high temperature, but below its melting point, so that the particles stick together.
Sputtering	A process by which sufficient energy is transferred to the atoms of a target material so that they escape into the vacuum space. The energy transfer may be effected by an electron beam or by ions generated in the gas phase by a gas discharge for example.
<i>Supplier</i>	Any legal entity providing items or services in accordance with a contractual document. An all-inclusive term used in place of any of the following third parties DA's, vendor, seller, contractor, subcontractor, fabricator, consultant, and their sub-tier levels).
Trapped volume	In this context either (i) a void within a material with a small passage opening to the vacuum space (the passage will have a transverse dimension smaller than that of the void.) (ii) a space between two surfaces in contact which is not well vented to the vacuum space.
Ultrahigh vacuum (UHV)	Pressures $< 10^{-7}$ Pa.
Undetectable leaks	Leaks with a value below the sensitivity (minimal detectable leak rate) of the equipment being used to try to find them.
Vacuum arc	A vacuum discharge which carries sufficient current to melt the surface of the material into which it comes into contact.

Vacuum baking	Baking a vacuum item which is totally immersed in a vacuum.
Vacuum barrier	A boundary between a vacuum space and another space.
Vacuum component or item	Any item with one or more surfaces exposed to vacuum. The term includes individual components (like a fixing screw for example), a sub assembly (like a pumping port) or a complete assembly (like the whole vacuum vessel).
Vacuum discharge	A mechanism whereby the residual gas inside a vacuum system becomes ionised and hence electrically conducting.
Vacuum flange	A demountable vacuum joint, normally used in pairs.
Vacuum seal	In this context, a gasket trapped between two vacuum flanges to create a leak tight joint.
Vacuum space	A bounded system held at sub-atmospheric pressure.
Vacuum Specialist	A person nominated by the ITER Vacuum Responsible Officer as an expert in a particular field of vacuum science or technology.
Vacuum system	Any assemblage of vacuum items forming a discrete, independent vacuum space, comprising at the minimum a vacuum envelope, pumping and pressure measurement.
Vacuum valve	A mechanical device which can be used to isolate or link two individual vacuum spaces, depending on its state.
Venting	Opening a vacuum space to another space.
Welding	A technique for joining two items by melting the interface region, with or without the use of a filler material.

Standards.

EN 10204 Metallic products. Types of inspection documents.

ITER Vacuum Handbook Appendix 22

Guideline (not under Configuration Control)

22. Allowable strain in cryogenic piping and cryogen components

22.1. Background

Helium leakage from cryogenic pipework within the ITER cryostat, cryo-pumps, cryo-lines, feeders or cold valve boxes could severely affect ITER's operational mission. Most critical is leakage within the ITER cryostat due to the complexity to both find and repair leaks. When austenitic stainless steel tube or pipes are cold worked then there are two changes which can occur which may lead to an increased risk of future leakage:

1. The cold working can lead to a transition from austenitic to martensitic steel. This transition may only occur when the pipe is cooled to cryogenic temperatures. On cooling to cryogenic temperature the cold formed parts can have reduced ductility and are brittle. They may also then be affected by a magnetic environment.
2. The cold working can lead to intergranular corrosion with the precipitation of chromium. This is an issue if the cold worked areas are subsequently welded.

22.1. Requirement

Helium containing parts made from stainless steel 304L, 304LN, EN1.4306, EN1.4307, where the deformation from cold working is $\geq 12\%$ (100x tube OD/bend diameter) shall be solution annealed if it is to be used at cryogenic temperature.

Helium containing parts made from stainless steel 316L, 316LN, EN1.4404, EN1.4429, EN1.4435, where the deformation from cold working is $\geq 24\%$ (100x tube OD/bend diameter) shall be solution annealed if it is to be used at cryogenic temperature $< 70\text{K}$.

Note:- in cold worked pipes where the above limits are exceeded, solution annealing can only be avoided if there is no welding in the strained areas and no operational flexing or stress on the pipe or that it can be proven that no significant austenitic to martensitic transformation has or will occur at the operating temperature.

22.2. Solution annealing

The annealing temperature shall be $1050^{\circ}\text{C} \leq T \leq 1150^{\circ}\text{C}$ during a short heating time followed by a rapid cooling down to reach 500°C in 10 min maximum for 304/316L stainless steel. The annealing shall be performed in an inert atmosphere – argon or nitrogen can be used.

22.3. Basis of the requirements

It was advised by a leading engineer from one of the largest cryogenic companies that it was the practice to solution anneal components made from stainless steel where the cold work

resulted in a strain greater than 12 % in any critical cryogenic application. The company data substantiating this is not openly available and hence it is investigated from other sources below.

22.3.1. Austenitic

Austenitic steels can be susceptible to martensitic

- Cooling below
- Elastic stress
- Deformation
- Combination of

22.3.2. Higher

Higher alloying of the stable austenite [6]:

- 304L (1.4306/1.4307) metastable
- 316L (1.4404/1.4429/1.4435) slightly metastable
- 310 stable

22.3.3. Cold work at room temperature

Cold work at room temperature enhances martensitic transformation (decreases austenite stability) at cryogenic temperature.

- For slightly metastable austenite testing at LN (77K) cannot be used for to indicate results and performance at lower temperature (e.g. 4K).
- Some material experts indicate a ratchet effect on repeated cooling.
- Once martensite has been formed reversion will not happen until above $\sim 400^{\circ}\text{C}$ (673K) [1]

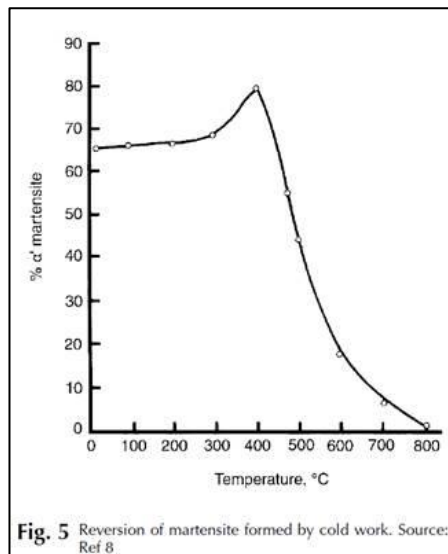

steels

metastable and are transformation by [6]:

ambient

the above

alloying of the stainless steel

stainless steel prompts more

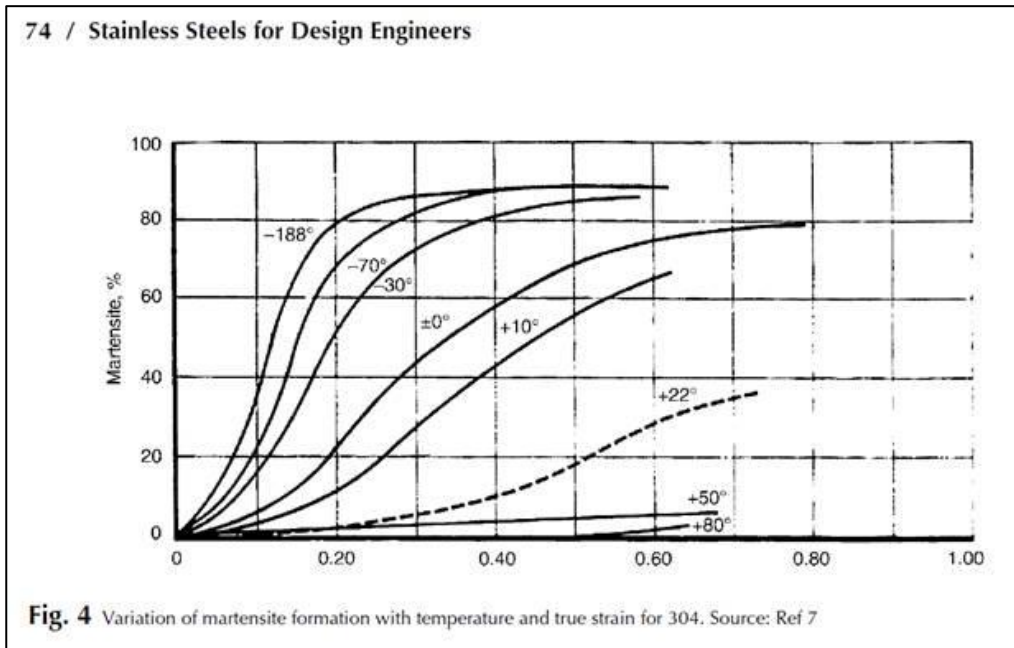

Figure 1 From [1].

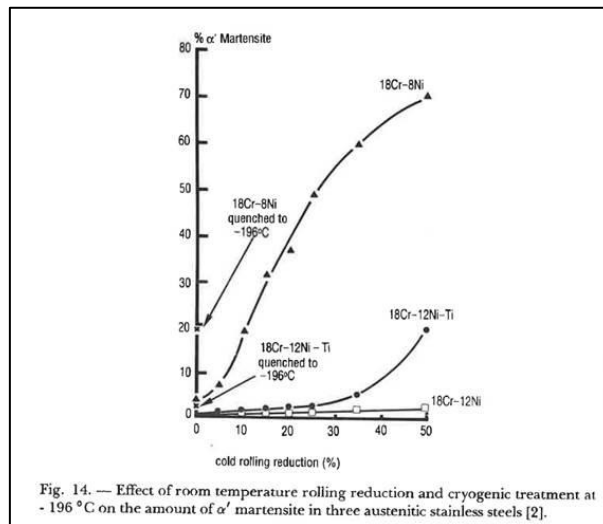

Figure 2 from [3].

22.3.4. SS304L the Effect of Martensitic Transformation

The martensitic transformation in 304L is well documented and several published results show a clear relationship between cold work and transformation temperature [1],[2],[3]. This can be seen in the figure 2 above and figure 3 below.

12% cold work is hence a recommended maximum strain for operation at cryogenic temperature <80K.

Figure 3 from [1].

22.3.5. SS316L the Effect of martensitic transformation

Figure 2 shows that with 12 % Ni the effect of martensitic transformation with strain at 80K is negligible but gives no information on cooling to lower temperatures. The effect of the alloy composition in stainless steels ranging between 11% and 18% Cr and between 8% and 12% Ni was investigated in [5]. The left diagram below depicts the reduction of the transition temperature M_s with increasing nickel content. The right diagram depicts the reduction of the transition temperature M_s with increasing chromium content. The formula for the transition temperature M_s presented in [5] gives for 316L (1.4404 or 1.4429 according to EN 10222-5) a transition temperature below 0K, hence no martensitic transformation occurs by cooling to the material, only with an additional elastic/plastic deformation will the martensitic transformation occur. However, there is no published test data that can be found which directly shows the 316 transformation temperature with cold work or the level of strain which is need to induce the transformation. This is likely due to the difficulty to perform such test at very low temperatures near 4K.

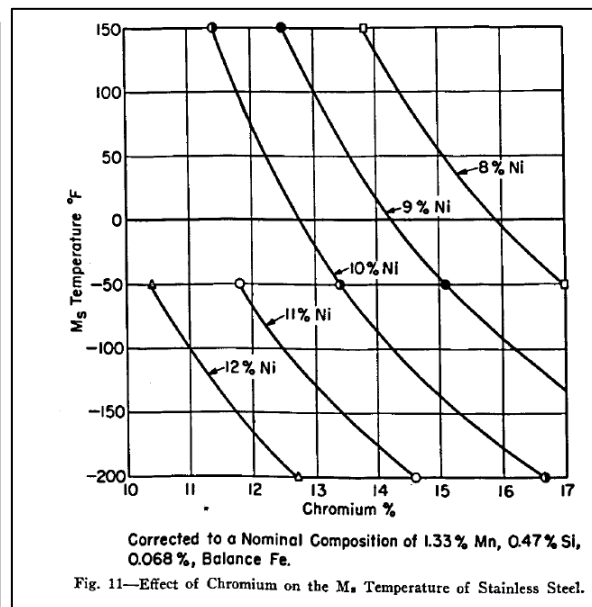
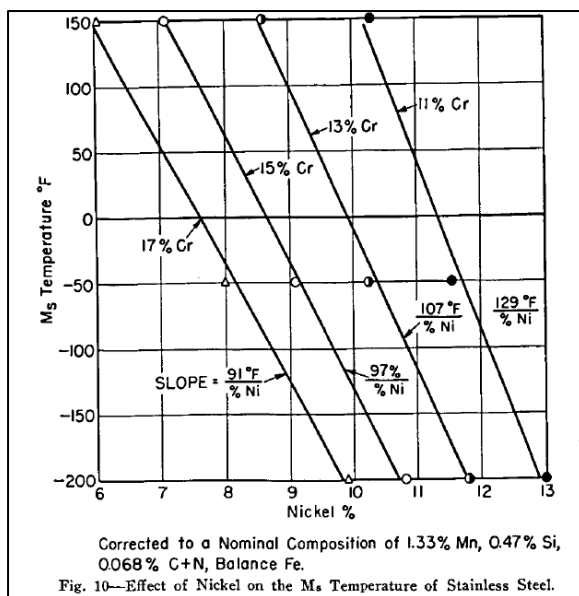

In order to make a judgment of the level of acceptable strain a comparison between 304L and 316L can be made from data produced by a different test method from [4]. The two diagrams

in Figure 4 below, show the austenite to martensitic transformation at different temperatures where the strain was induced at those temperatures. When the graphs are compared, the point where there is approximately 50% martensite phase in 304L coincides with the previously described 12% limit, and for 316L it can be seen that similarly the same point is at around 24% strain for 4 K. So it is reasonable to conclude that for 316L at 4K then solution annealing is required if the strain from cold work is above 24 %.

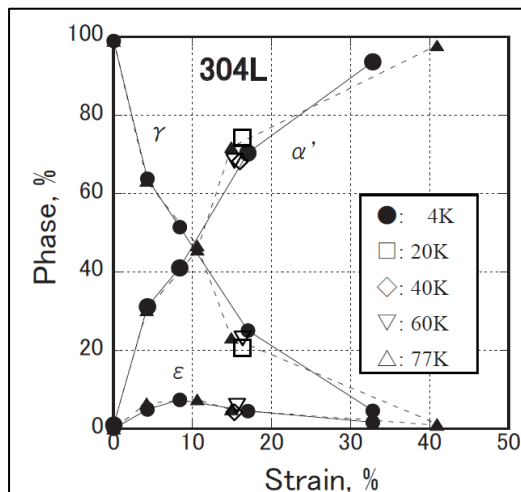

Fig. 12 Volume fractions of the ε - and α' -martensite for SUS 304L obtained by X-ray diffraction analysis of samples deformed at 4 K to 77 K.

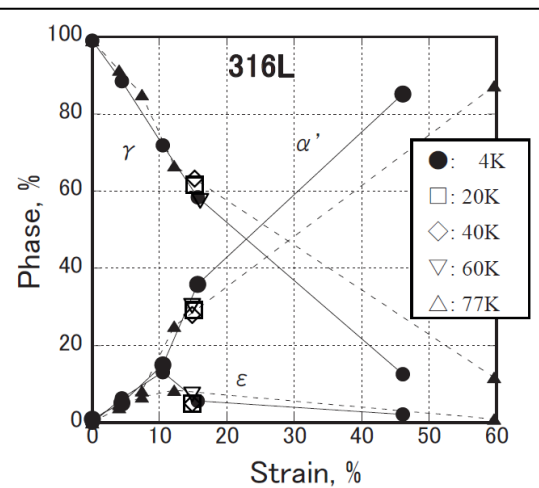

Fig. 13 Volume fractions of the ε - and α' -martensite for SUS 316L obtained by X-ray diffraction analysis of samples deformed at 4 K to 77 K.

Figure 4 from [4].

22.4. References

- [1] McGuire, MF., 2008, *Stainless Steel for Design Engineers*, ASM International, ch.6 Austenitic Stainless Steels.
- [2] Lebedev, AA., Kosarchuk VV., 2000, Influence of phase transformations on the mechanical properties of austenitic stainless steels, *International Journal of Plasticity*, v16, p749-67
- [3] Lacombe 1993, [*Aciers Inoxydables*], Les Editions de Physiques, Les Ulis, Paris p 564
- [4] Ogata, T., Yuri, T., Ono, Y., 2007, Load-Displacement Curves, Specimen Heating and Strain induced Martensitic Transformations of Austenitic Stainless Steels at Cryogenic Temperatures.
- [5] Eichelmann, Hull, 1952; The effect of composition on the temperature of spontaneous transformation of austenite to martensite in 18-8 type stainless steels
- [6] Material Studies for magnetic fusion energy applications at low temperatures-VI, pages 11-39

ITER Vacuum Handbook Attachment 1

Baseline Report

At. 1. Inspection and Qualification of Welded Joints

1. Scope

This Attachment relates to welding of vacuum boundaries and outlines the procedures for documentation, qualification, approval and testing.

Whilst this Attachment is based on the international standards ISO 9606, ISO 15614 and ISO 15609, additional requirements are specified to achieve the high integrity and reliability of the vacuum systems to ensure the required ITER machine reliability. Specifically this Attachment is more stringent in places than the standards in the range of approval for joint types, mechanical testing and acceptance criteria.

The requirements are designed to complement codes which may be used. Where requirements differ in general the more stringent standard should be applied or advice sort from ITER.

2. The Welding and Inspection Plan

Before fabrication can commence the *supplier* shall prepare for approval a weld plan. The weld plan is a drawing which cross references each welded joint to a supporting Welding Procedure Specification (WPS).

3. Welder and operator Qualification

The welder qualification is intended to show the competence of the welder/operator for implementing the specified WPS.

Welder qualification shall be in accordance with ISO 9606 or equivalent standards agreed in advance. For welding operators ISO 14732 shall be used.

Other standards may be approved by ITER on submission of documentation detailing the equivalence between the proposed standards and the standards quoted herein. All standards and documentation pertaining to equivalence shall be submitted in English and must be agreed in advance of welding operations.

The *supplier* shall establish and maintain a list of qualified welders and operators. This list shall include their individual identification and range of welds for which they are qualified.

4. Applicable Standards

The latest revisions of the standards listed in Table 4-1 shall be applied in the procedure, qualification, and acceptance testing etc. of any welding process and form, where applicable, part of this attachment. Alternative national standards may be submitted for approval but they must meet the minimum technical requirements of this Attachment. Alternatives must be formally accepted through written communication before welding can commence.

Where this attachment is more stringent than the standards, this document takes precedence.

Where specified in this document, additional requirements to or requirements differing from the quoted international standards have been highlighted *in bold italics*.

ISO 15607	Specification for the qualification of welding procedures for metallic materials – general rules
ISO 15614	Specification and qualification of welding procedures for metallic materials-welding procedure test
ISO 15609	Specification and qualification of welding procedures for metallic materials – Welding procedure specification
ISO 17637	Non-destructive examination of fusion welds. Visual examination.
ISO 4063	Welding and allied processes – Nomenclature of processes and reference numbers.
ISO 3452	Non-destructive testing. Penetrant testing.
ISO 17638, ISO 9934	Non-destructive examination of welds. Magnetic particle examination of welds
ISO 17636	Non-destructive examination of welds. Radiographic examination of welds.
ISO 17640	Non-destructive examination of welds. Ultrasonic Examination.
ISO 9606-1	Qualification test of welders – Fusion welding – Part 1: steels.
ISO 9606	Qualification test of welders – Fusion welding – Part 2: aluminium and aluminium alloys.
ISO 14344	Welding and allied processes – Flux and gas shielded electrical welding processes – Procurement guidelines for consumables.
ISO 5817	Fusion welded joints in steel, nickel, titanium and their alloys (beam welding excluded) – Quality levels for imperfections.
ISO 14732	Welding personnel. Approval testing of welding operators
ISO 9712	Non-destructive testing - Qualification and certification of NDT personnel
ISO 22825	Non-destructive testing of welds - Ultrasonic testing - Testing of welds in austenitic steels and nickel-based alloys
ISO 10380	Corrugated metal hoses and hose assemblies

Table 4-1 Standards relating to welding.

5. Welding Procedure Specification

The Welding Procedure Specification (WPS) is a document which details all the variables which must be defined to produce a weld of acceptable quality. The qualification of the WPS shall be performed in accordance with this Attachment.

Each WPS shall detail each type of weld and shall include, but not be limited to, the following in accordance with ISO 15609:

- Identification of equipment manufacturer
- Equipment calibration records
- Examiner or test body

- WPS number
- Parent material(s), defining which joint element is comprised of a given material
- Filler material(s): classification, type, trade name, flux, diameter of electrode, rod, or wire
- Joint sketch and weld run sequence
- Range of qualified thicknesses and/or diameters
- Welding position
- Welding process (in accordance with ISO 4063)
- Welding technique (single, multipass etc)
- Groove or edge preparations (cleaning, degreasing, jiggling etc)
- Shielding and backing gas (composition and flow rates)
- Welding equipment parameters which may include:-
 - AC or DC
 - Polarity
 - Current range
 - Voltage range
 - Pulsed welding parameters
 - Tungsten electrode diameter and type
 - Nozzle diameter
- Backing: method and type, materials and dimensions
- Back gouging: method
- Heating: pre-heat temperature, interpass temperature, post weld temperature
- Drying and preservation temperatures for covered electrodes (if applicable)

Additional Parameters for automatic welding may include:

- Welding equipment specification
- Tool and programme numbers (where applicable)
- Travel speed range
- Wire feed speed range
- Arc Voltage Control parameters

For special processes (remote welding etc) additional information may be required.

6. Welding Procedure Qualification Record

The Welding Procedure Qualification Record (WPQR) is used to record all the relevant data from the welding of test pieces in the qualification of the WPS.

- The qualification of the WPS provides proof that the defined welding process, will achieve a weld of acceptable quality. The welding and testing of this must be witnessed by an ITER recognised Independent Inspection Authority.

All welding data and results from the required non-destructive and destructive testing shall be documented using a Welding Procedure Qualification Record (WPQR). It can also be called Welding Procedure Approval Record (WPAR).

6.1. *Qualification of the Welding Procedure Specification*

An existing Welding Procedure Qualification Record (WPQR or WPAR) is acceptable if the following conditions are met:

- The test must have been performed in the same environment as proposed for production, using the same welding technique, process, joint configuration and welding equipment (for mechanised welds)
- The allowable ranges are the same with regard to essential variables.
- The related Preliminary Welding Procedure Specification (pWPS) has been qualified in accordance with ISO 15614
- The test must have been witnessed by an ITER recognised Independent Inspection Authority

Weld produced for qualification must be performed by suitably qualified welders.

The *supplier* must also demonstrate that the welding equipment and plant use for qualification is properly maintained and calibrated in accordance with the relevant operation and maintenance schedules.

6.2. *Extent of Approval*

6.2.1. Material Groups

For differing grades of stainless steel (304, 304L, 316, 316L and 316LN-IG), cross qualification can be accepted for manual welds when 316L filler is used. Cross qualification is not acceptable for automatic welds. Transition welds joining dissimilar materials other than those listed above must have specific qualification tests performed.

6.2.2. Base Materials

Qualification on production metal type and grade is mandatory. There is no requirement for the use of material from the production heat number for qualification of the WPS.

ISO9001:2000 (clause 7.5.2) states that welding is always a special process. Welding processes commonly used in the manufacture of ITER components with a vacuum classification (according to ITER Vacuum Handbook) and their classification in the context of ITER are listed in Table 1. For special welding processes (Table 6-2) Production Proof Samples shall be manufactured from the production heat number.

Name	N [†]	AWS ^φ	Special (Yes/No)
Gas metal arc welding	131	GMAW	No
	135		
Manual Gas Tungsten Arc Welding	141	GTAW	No
Automatic, or mechanized Gas Tungsten Arc Welding			Yes
Electron Beam Welding	51	EBW	Yes
	511		
Laser Beam Welding	521	LBW	Yes
	522		
† N reference numbers as specified in ISO 4063 (in the European Union published as EN ISO 4063)			
φ AWS reference codes of the American Welding Society are commonly used in North America			

Table 6-1 Welding Processes.

6.2.3. Thickness Range

6.2.3.1. Thickness Range for Welds Excluding Fillet and Branch

The qualification of a welding procedure test on thickness t shall include qualification for thickness in the ranges given in Table 6-2 in accordance with ISO 15614.

Thickness of test piece 't' (mm) (where 't' is the thickness of the thinner material)	Range of Approval ^{1,2} (Dimensions in mm)		
	Parent material thickness		Deposited weld metal thickness for each process 's'
	For single run or single run from both sides	Multi-run	
$t \leq 3$	0.5 t to 2 t		Max. 2 s
$3 < t \leq 12$	0.5 t (3 min) to 1.3 t	3 to 2 t	Max. 2 s
$12 < t \leq 20$	0.5 t to 1.1 t	0.5 t to 2 t	Max. 2 s
$20 < t \leq 40$	0.5 t to 1.1 t	0.5 t to 2 t	Max. 2 s when $s < 20$ Max. 2 t when $s \geq 20$
$40 < t \leq 100$		0.5 t to 2 t	Max. 2 s when $s < 20$ Max. 200 when $s \geq 20$
$100 < t \leq 150$		50 to 2 t	Max. 2 s when $s < 20$ Max. 300 when $s \geq 20$
$t > 150$		50 to 2 t	Max. 2 s when $s < 20$ Max. 1.33 t when $s \geq 20$

1 - When impact requirements are specified but impact tests have not been performed, the maximum thickness of qualification is limited to 12 mm.
2 - The range of approval may have to be reduced in order to avoid hydrogen cracking.

Table 6-2 Range of Approval for material thickness and weld deposit thickness— all welds.

6.2.3.2. Thickness Range for Fillet Welds

The qualification of a welding procedure test on thickness t shall include qualification for thickness in the ranges given in Table 6-3 in accordance with ISO 15614.

Thickness of test piece 't' (mm)	Range of approval (Dimensions in mm)		
	Material thickness	Throat thickness	
		Single run	Multi-run
$t \leq 3$	0.7t to 2 t	0.75 a to 1.5 a	No restriction
$3 < t < 30$	3 to 2 t	0.75 a to 1.5 a	No restriction
$t \geq 30$	≥ 5	†	No restriction

Note 1: a is the throat thickness of the test piece
Note 2: Fillet welds cannot be qualified by Butt welds
 † For special applications only. Each throat thickness has to be proofed separately by a welding procedure test

Table 6-3 Range of qualification for material thickness and throat thickness of fillet welds.

6.2.3.3. Thickness Range for Branch Pipes (Diameter Range)

The qualification of a welding procedure test on diameter D shall include qualification for diameters in the following ranges give in Table 6-4 in accordance with ISO 15614.

Diameter of test piece D^{1,2} (in mm)	Range of approval
D ≤ 25	0.5 D to 2 D
D > 25	≥ 0.5 D up to plates (25 mm min)
1) D is the outside diameter of the pipe or the outside diameter of the set-on branch pipe 2) Approval given for plates also covers pipes when outside diameter is > 500 mm	

Table 6-4 Range of approval for pipe and branch connections.

6.2.4. Range of Approval of Welded Joints

Lip weld and Automatic socket welds shall be qualified on actual size within nominal material specification tolerances. Pre-weld /socket/spigot gap shall be adequate to preclude post-weld abutment contact and minimise weld stress. The range of approval for other types of joint is given in Table 6-5.

6.2.5. Range of Approval Welding Consumables

All consumables shall be certified to a standard acceptable to the ITER IO (e.g. ISO 14344). In the case of manual welding processes the approval range of filler materials covers other filler metals as long as they are in the same range and chemical composition.

In the case of automatic and semi automatic welding processes the welding consumables used for qualification shall be the same batch as those used for production welds. Following any change during production, weld samples shall be welded and examined prior to the continuation of production with the new batch of consumables. Qualification using filler does not qualify autogenous (fusion welding with out filler material) welds or vice versa.

6.2.6. Welding Processes

In all cases, any change in the welding process will require a requalification of the process. In addition, in the case of automatic welding any change to the welding equipment will require requalification.

6.2.7. Welding Position

Welds for qualification shall be done in local conditions similar to the local conditions where the production weld will be made. Local access to the test piece (in terms of welder access) and the orientation of the test piece (relative to the welder) shall be similar to those for the

production weld for which they qualify.

Type of Joint in Approval Test Piece			Range of Approval												
			Butt welds on plate				T Butt welds on plate				Fillet weld on plate	Butt welds on pipe		Branch welds on pipe	
			Welded from one side		Welded from both sides		Welded from one side	Welded from both sides	Welded from one side			Fillet weld on pipe	Set on	Set through	
			With backing	No backing	With gouging	No gouging			With backing	No backing					
Butt weld on plate	Welded from one side	With Backing	✓	✗	Δ	Δ	✗	✗	✗	✗	✗	✗	✗	✗	
		No Backing	Δ	✓	Δ	Δ	✗	✗	✗	✗	✗	✗	✗	✗	
	Welded from both sides	With gouging	✗	✗	✓	Δ	✗	✗	✗	✗	✗	✗	✗	✗	
		No gouging	✗	✗	✗	✓	✗	✗	✗	✗	✗	✗	✗	✗	
Butt weld on pipe	Welded from one side	With backing	Δ	✗	Δ	Δ	✗	Δ	✗	✓	✗	✗	✗	✗	
		No backing	Δ	Δ	Δ	Δ	Δ	Δ	✗	Δ	✓	✗	✗	✗	
T Butt weld on plate	Welded from one side		✗	✗	✗	✗	Δ	Δ	✗	✗	✗	✗	✗	✗	
	Welded from both sides		✗	✗	✗	✗	✗	✓	✗	✗	✗	✗	✗	✗	
Fillet weld	Plate		✗	✗	✗	✗	✗	✗	✓	✗	✗	✗	✗	✗	
	Pipe		✗	✗	✗	✗	✗	✗	Δ	✗	✗	✓	✗	✗	
Branch weld in pipe	Set on		✗	✗	✗	✗	✗	✗	✗	✗	✗	✗	✓	✗	
	Set through		✗	✗	✗	✗	✗	✗	✗	✗	✗	✗		✓	

Key:
 ✓ Indicates the weld for which the WPS is approved in the approval test
 Δ Indicates those welds for which the WPS is also approved
 ✗ Indicates those welds for which the WPS is not approved

Table 6-5 Range of approval for type of joint.

6.3. Non –Destructive Examination

Supplier's inspectors shall be competent in accordance with ISO 9712.

6.3.1. Examination

After post weld heat treatment and prior to destructive testing, test pieces shall be examined by the following:

- Visual examination (in accordance with ISO 17637)
 - Dye Penetrant testing (in accordance with ISO 3452) or Magnetic particle testing (in accordance with ISO 9934)
 - Inspection using Photothermal camera is permitted in the case where the manufacturer has qualified the method/acceptance criteria prior to the weld qualification
 - Radiographic examination (in accordance with ISO 17636)
- and/or
- Ultrasonic examination (in accordance with ISO 17640 and ISO 22825 for austenitic steels and nickel alloys)

For a pipe or plate of 2 mm (or less) wall thickness, the method of examination shall be agreed prior to examination.

6.3.2. Acceptance Criteria

Defects which are detected by the relevant non-destructive examination method shall be assessed in accordance with ISO 5817 level B. In particular acceptance criteria are detailed in Table 6-6. Table 6-6 is in accordance with ISO 5817 however contains additional requirements for production vacuum boundary welds.

Defect Type		Permitted maximum
Planar Defects	Cracks or lamellar tears	Not permitted
	Lack of root fusion	
	Lack of side fusion	
	Lack of inter-run fusion	
	Lack of root penetration	
Solid inclusions	Slag inclusions - individual	20% of t or 2 mm, which ever is smaller
	Slag inclusions - Group	Aggregate length not to exceed t in a length of 12 t, except when the distance between successive indications exceeds 6L where L is the longest indication in the group
	Inclusions – <i>Tungsten</i> or Copper	Not permitted
Cavities	Isolated pores - round	Diameter <20% t or 2 mm, whichever is smaller
	Gas pore uniformly distributed porosity	1% for single layer (2% for multi-layer) by area where the area of the radiograph to be considered is the length of the weld affected by the porosity times the maximum thickness of the weld
	<i>Elongated pores - wormholes</i>	<i>Not permitted</i>
	<i>Linear Porosity</i>	<i>Not permitted</i>
Profile defects	<i>Under cut</i>	<i>Some intermittent undercut permitted. Depth not to exceed 0.5 mm for t > 3 mm or 10% for t < 3 mm. Under cut to blend smoothly with the parent material.</i>
	Incompletely filled groove, sagging. Root concavity, shrinkage	0.05 t or 0.5 mm, which ever is smaller. Weld thickness shall not be less than the parent plate thickness

	groove	
	Excess penetration - pipe	Not greater than 5% of the pipe internal diameter up to 2 mm max.
	Excess penetration – plate	t = 0.5 to 3 mm: , h ≤1 mm+10% b t > 3mm: h ≤1 mm+20% b max 3mm.
		h=height of excess penetration on backside of plate and b the width
	Excess weld material	Not greater than 10% weld width
	Misalignment	Not greater than 10% of the parent material thickness
	Fillet leg length (asymmetry)	Unequal leg length should not exceed 20% of the fillet throat thickness
	Burn through	Not permitted
Other	Root oxidation	Not permitted where a backing purge gas is specified in the WPS

Table 6-6 Acceptance levels

6.4. Destructive Tests

6.4.1. Test Specimens

The number of test specimens that shall be subjected to destructive testing is given in Table 6-7 in accordance with ISO 15614.

TEST SPECIMEN	No of Tests
<u>BUTT WELD</u>	
Transverse Tensile (room temp.)	2
Root Bend (for t <12mm)	2
Face Bend (for t <12mm)	2
Side Bend (for t >12mm)	4
Transverse Tensile (design temp. if required by tech. spec.)	1
Impact test (for t ≥12 mm one set from weld metal and one set from HAZ if required by tech. spec).	2
Macro-examination (with photo)	1
Micro-examination x 200 (if required by tech spec.)	1
Hardness test survey	1
Burst test†	1
<u>FILLET WELD</u>	
Fracture Test	1
Macro-examination (with photos)	4

Micro-examination x 200 (if required by tech. spec.)	2
Hardness Survey	2
<u>T-BUTT/BRANCH CONNECTION</u>	
Macro-examination (with photos)	4
Micro-examination x 200 (if required by tech. spec.)	2
Hardness Survey	2
<u>SOCKET/LIP WELD[†]</u>	
Macro-examination (with photos)	4
Micro examination x 200 (if required by tech. spec.)	2
Hardness Survey	2
† Longitudinal butt weld on bellows (or flexible) tube to ISO 10380	

Table 6-7 Number of destructive test specimens.

6.4.2. Test Results

Unless specified differently in Table 6-8 destructive testing and test results shall comply with ISO 15614.

<i>Bend test (stainless steel and nickel alloy only)</i>	<i>The bend angle shall be 180° round a former of diameter 2t, where t is the thickness of the specimen. The bend test specimen shall have no open defects exceeding 2 mm measured in any direction on the convex surface after bending.</i>
<i>Micro - Examination</i>	<i>In general micro-examination shall only be required for welds which form part of the vacuum boundary or are in contact with cryogenic liquids. If required micro- examination tests shall be specified in the technical specification.</i>
<i>Macro Examination</i>	<i>For lip welds, penetration shall be 0.7t where t is the thickness of the thinner material.</i>

Table 6-8 Acceptable test results.

6.4.3. Qualification for Welds Under Stressed Applications

Additional destructive tests to those listed in Table 6-7 to qualify welds under stressed applications may be required as defined in the technical specification.

7. Production Welds

Production welds shall be performed to qualified procedures by qualified welders.

The WPS shall be available for reference by welders or welding operators, by the responsible welding engineer and by the authorized inspector.

The contractor must also demonstrate that the welding equipment and plant is properly maintained and calibrated in accordance with the relevant operation and maintenance schedules.

7.1. Inspection of Fusion Welded Joints

After post weld heat treatment welds shall be subject to the following tests:

- Visual examination (in accordance with ISO 17637)
- Dye Penetrant testing (in accordance with ISO 3452) if permitted†. (Inspection using Photothermal camera is permitted in the case where the manufacturer has qualified the method/acceptance criteria prior to the weld)
- Radiographic examination (in accordance with ISO 17636) and / or
- Ultrasonic examination (in accordance with ISO 17640 and ISO 22825 for austenitic steels and nickel alloys)

† See ITER Vacuum Handbook Section 7.1.4.

The range of wall thickness and preferred volumetric examination method is given in Table 7-1.

Defects which are detected by the relevant non-destructive examination method shall be assessed in accordance with Table 6-6.

For all VQC 1A, VQC 2A water boundaries and vacuum boundary welds which become inaccessible, 100% volumetric examination of production welds shall be performed, unless a method of pre-production proof sampling is approved.

For all other vacuum boundaries, volumetric examination of 10% of production welds shall be performed unless a method of pre-production proof sampling is approved. In the event of failures, this shall be increased to 100% examination of the batch, defined as same welder/same WPS/ same weld. Acceptance criteria are specified in Table 6-6

On welds where it is specified that volumetric examination be performed and radiography or ultrasonic inspection is not possible, Production Proof Sampling is required.

Wall Thickness	Preferred Volumetric Examination Method
Wt < 12 mm	Radiography
12 mm > wt < 19 mm	Radiography & Ultrasonic
wt > 19 mm	Ultrasonic

Table 7-1 Range of wall thickness and preferred volumetric examination method.

7.2. Production proof samples

Welds where radiography or Ultrasonic testing is impractical (e.g. welds that are not full penetration butt welds) must be covered by Production Proof Sampling (PPS).

Each PPS will only represent a specific type of weld and must use the same materials, thickness and set-up as the production weld.

For VQC 1 and 2 vacuum boundary welds a PPS must be welded during the same shift as the

production welds and by the same welder using the same equipment to be representative of the production welding.

If more than one welder welds the production welds, each must perform a PPS. PPS's are required each shift production welding is being performed to represent the welds performed on that shift.

For VQC 3 and 4 vacuum boundary welds a PPS shall be welded for each welder performing the production welds.

PPS's should be sectioned and macro examined in four places (including one stop/start area). Photographs of the macros giving the date the PPS was welded, the welder's identity and identifying the production welds it is covering must be included in the final documentation package.

An ITER representative will normally witness PPS welding and all PPS macros shall be reviewed. Operations with witness and hold points to facilitate this must be incorporated in the Work Schedule.

As the PPS is a representative sample, rejection of the macro will result in rejection of all welds covered by this PPS.

7.3. Helium Leak Testing of Production Welds

100% of vacuum sealing welds (VQC 1A, 2A, 3A, 4A) shall be subject to helium leak testing in accordance with the requirements and procedures of the ITER Vacuum Handbook.

7.4. Repair by welding of production welds

No weld repair shall be performed without qualification of the welding procedure. Welding procedures used for welding repair shall be qualified in accordance with this document.

8. Documentation

All quality assurance documentation required by this procedure shall form part of the delivery to ITER, and shall include:

- Weld plans
- WPS's
- WPQR's and test reports
- Welder qualification's and test reports
- PPS test reports
- Production weld test reports
- Reports on weld repairs
- Non-Conformance Reports

ITER Vacuum Handbook Attachment 2

Report

At. 2. Cleanliness Requirements for the Assembly of Vacuum Equipment

1. Terminology

The following terms and acronyms listed in are used throughout this Attachment.

Term/acronym	Contextual meaning
<i>Accepted</i>	Accepted for use by the ITER Vacuum Responsible Officer
ALARA	As Low As Reasonably Achievable
Ex-vessel work	Work for which the operator(s) remains physically outside the vacuum system (e.g. assembly of a vacuum pipework run)
In-vessel work	Work for which the operator(s) must enter the vacuum system to perform (e.g. assembly in the main VV or cryostat)
Operator(s)	Person(s) performing the work
RA	Risk Assessment
UT	Ultrasonic Testing
VV	ITER main Vacuum Vessel
VQC	Vacuum Classification
WRO	Work Responsible Officer – Responsible for preparation of the RA and WI. The WRO is also responsible for ensuring that the work is performed to the WI and any safety requirements are satisfied
WI	Work Instruction – as part of the documentation package includes written procedures such as method statements

Table 1 Terms and acronyms with meaning in context of this document.

2. Scope

This Attachment sets out the requirements which must be satisfied when performing assembly work on, or in, the ITER systems which have been assigned a VQC [1]. This document is applicable for work performed at the ITER site.

It covers

- preliminary assembly work in assembly areas
- final assembly and integration work inside and outside the vacuum equipment.

3. Purpose

The purpose of the requirements described herein are to ensure that the overall contamination levels in the various vacuum equipment of the ITER machine when it is brought into operation are commensurate with the Vacuum Classification (VQC) of the pertinent vacuum equipment. All procedures and processes used during assembly and testing work of ITER vacuum systems equipment shall comply with the requirements of the ITER Vacuum Handbook [1].

4. General Requirements

These requirements are applicable to all assembly work for all items with a VQC. Subsequent sections detail VQC specific requirements.

4.1. Management of Work

All work shall be performed in compliance with the ITER Health & Safety & Environment management plan which concerns the safety of work on the IO site. The basic requirements of the referenced document which must be satisfied are outlined below.

4.1.1. Risk Assessment

The risks associated with assembly and test of vacuum equipment shall be assessed prior to work commencing. The risk assessment shall be performed by a competent person and approved by the IO. Prior to work commencing all controls identified to lower the risks to a level commensurate with the principles of ALARA shall be in place.

4.1.2. Work Instruction

All assembly and test operations shall be performed to a Work Instruction (WI). The WI may take the form of, for example, a written procedure or method statement. The WI shall be approved by the IO and supported by a relevant Risk Assessment (RA).

The requirements for cleanliness and cleanliness control as described in this Attachment shall be stated in the WI as shall the processes to achieve the requirements as stated herein.

4.1.2.1. Deviations from the WI

During the execution of the tasks as defined in the WI it may be necessary to deviate from the WI. All deviations from the WI shall be agreed with the WRO prior to execution. The WRO shall update the WI accordingly to account for the deviation. Any unauthorised deviation from the WI shall be reported to the WRO.

4.1.3. Personnel

No work shall be performed except by competent personnel trained to perform the work to be carried out.

4.2. Area Designation

The area in which the work shall be performed shall be designated according to the VQC of the system being worked upon. All general and any specific requirements pertaining to the work being performed in the area shall be clearly displayed in the working area preferably with the WI and RA.

4.3. Operator Attire

All operators performing work on vacuum equipment with any VQC where there is a risk of the operator coming into physical contact with the vacuum facing surfaces shall wear suitable attire. The exact nature of the attire to be adorned shall be specified in the WI and displayed on the area designation (section 4.2).

4.3.1. Personnel Protective Equipment

The operators shall adorn PPE as defined as a result of the Risk Assessment. All PPE shall be clean and free from surface contamination such as grease and oil.

4.3.2. Ex-vessel work

As a minimum and in addition to the requirements of 4.3.1 the operator shall wear the following when assembling vacuum equipment ex-vessel;

- Clean powder free latex or nitrile outer gloves
- Clean lint free overalls

4.3.3. In-vessel work

In addition to the requirements of 4.3.2 the operator shall also adorn the following garments when performing work in-vessel;

- Clean plastic overshoes
- Hair nets or caps and beard covers where appropriate
- Clean plastic helmet cover

4.4. Tools

4.4.1. General

All tools shall be fit for purpose and shall be specified in the WI.

Prior to use all tools shall be cleaned by wiping with a clean lint free cloth dampened with isopropyl alcohol (IPA) or laboratory grade ethanol.

4.4.2. Tools for use in-vessel

All tools for use in-vessel shall come from a dedicated set of tools which are new or have only been used for in-vessel work.

Tools shall be logged into and out of the working area.

After each assembly stage a check shall be made to ensure all tools have been removed from the work area.

4.4.2.1. Hand Tools

Hand tools shall be stored in a clean tool container which may be transported into the working area. The tool container shall also include an inventory list of tools contained therein. Prior to removal from the work area the inventory of tools shall be checked against the inventory list. Any discrepancy between the tools in the container and the inventory list shall be reported to the Work Responsible Officer (WRO).

4.4.2.2. Power Tools

The use of power tools in-vessel shall be specified in the WI.

Prior to the use of power tools adjacent parts of the work area shall be screened off by the use of clean polyethylene sheeting, aluminium foil or the like to catch swarf, debris, etc. and to minimise its spread to other parts of the job.

Following each stage of such work, swarf, debris, etc., shall be cleaned up by vacuuming and surfaces wiped down with clean lint-free rags dampened with IPA or laboratory grade ethanol.

4.4.2.3. Welding/ Brazing Equipment

Welding and/ or brazing equipment shall be used only as specified in the WI. All operations of this type shall be supported by the relevant paper work (such as hot work permit) which shall be attached to the WI.

Prior to starting any such operation, surfaces to be worked on shall be cleaned by swabbing with an IPA or laboratory grade ethanol on clean lint-free rags.

Adjacent parts of the work piece shall be screened off by the use of clean polythethylene sheeting, aluminium foil or the like to catch weld spatter etc.

PPE such as welding screens shall be clean and new, or clean and dedicated for in-vessel work.

4.4.2.4. Tools Containing Fluids

The use of tools containing fluids, such as hydraulic jacks, shall be avoided where possible. Where the use of a tool containing fluid cannot be avoided then the following requirements must be satisfied.

The working fluid shall normally be air or glycol based.

The use of hydraulic tools containing oils as the working fluid is prohibited unless

accepted by the ITER Vacuum Responsible Officer.

The area surrounding to tool shall be protected, with plastic sheeting, from the possible release of the fluid.

As far as is practical the tool shall be wrapped in plastic sheet to prevent the possible spread of contamination from leaking fluid.

The WI shall include measures which must be taken in the event of loss of fluid from the tool into the work area.

4.4.2.5. *Equipment, trolleys, jigs, slings, etc.*

All such equipment, etc., shall be maintained in a fully serviceable manner.

All such items shall be operated in a manner such that no oils, greases, etc., can be transferred to surfaces in the clean area or that debris including particulates can be shed from the items.

4.4.2.6. *Vacuum Pumps*

All vacuum pumps for use in-vessel shall be dry (oil free) type.

4.4.2.7. *Specialised Tools*

The use of specialised equipment shall be by prior agreement with the WRO and only to the procedures as specified in the WI.

4.5. *Materials*

4.5.1. *Marking*

Indelible inks and paint used for temporary mark shall only be *accepted* for use under the following conditions:

The marking can be completely removed without residue

All markers shall **not** contain any contaminants as described below:

- Ferrite steel
- Chlorine content greater 0,25%
- Sulphur and sulphur compounds
- Products which may release elements: Pb, Hg, P, Zn, Cd, Sn, Sb, Bi, As, Cu, rare earth elements.

4.5.2. *Adhesive Tape and plastic coverings*

Adhesive tapes, peel-off preservative varnishes and temporary plastic coverings, used for

austenitic stainless steels shall meet the following requirements:

- halogen or sulphur content shall be less than 0,10% in weight
- less than 15 ppm of chloride and 10 ppm of fluoride shall be released through lixiviation.

4.5.3. Grinding and Cutting Wheels

Grinding and cutting wheels for use on vacuum equipment shall be alumina based and only used for austenitic stainless steel. Cutting wheels for use in vessel shall be *accepted* for use by the IO.

4.5.4. Products for Ultrasonic Testing (UT)

Only ITER approved [2] coupling fluids required for UT are accepted for use on vacuum equipment. Requirements pertaining to coupling fluids are detailed in the ITER Vacuum Handbook [1].

4.5.5. Products for Liquid Penetrant Examination

Only ITER approved liquid penetrant product families are *accepted* for use on vacuum equipment [2].

4.5.6. Machining Fluids

Only machining fluids *accepted* by the IO are acceptable for use on vacuum equipment [2].

4.5.7. Unacceptable Materials

It is prohibited for the materials listed in Table 2 to become in contact with the surface of vacuum equipment.

Metals	Plastics
Carbon steel	PVC
Zinc	
Lead	

Table 2 Prohibited materials.

5. Performance of Work

5.1. In-Vessel Dressing Working Procedures

The following general clean area procedures shall be followed and combined with good judgment in order to produce and maintain vacuum.

1. Controlled clean dressing area at entrance and exit of vacuum vessel will be set up with appropriate notices posted.
2. No food, drink, chewing gum or ablutions allowed within the vacuum vessel.
3. Clean protective clothing must be worn when working in-vessel. Clean overalls/coats, gloves and overshoes will be put on when entering the vacuum vessel and taken off upon exit.
4. Hands should be washed before wearing clean gloves. This must be done especially if any lotions or creams have been used.
5. Change clean gloves if contamination is suspected.
6. Cover hair and arms if there is any possibility of them contacting a clean vacuum surface.
7. Equipment brought into the clean dressing area for entry into vacuum vessel must be clean. Carts, stands, tools and other equipment must not be oily or greasy and must be wiped down with appropriate cleaning solutions immediately prior to entering the clean area. Note that wheels on carts must also be cleaned.
8. Tools that are cleaned for in-vessel use must not leave the clean area until end of job.
9. Expendable tools (saw blades, files, cutters, stainless steel wire brushes, grinding wheels, etc.) used shall be new and cleaned to minimize the potential for contamination.

5.2. Cutting, Drilling, Grinding, Filing and Polishing

Such operations shall only be carried out when specified in the work instructions.

Cutting fluids, lubricants, polishing materials, etc., may only be selected from those which have been *accepted* by IO for the relevant VQC.

Prior to starting any such operation, surfaces to be worked on shall be cleaned by swabbing with IPA or laboratory grade ethanol on lint-free rags.

Adjacent parts of the work piece shall be screened off by the use of clean polyethylene sheeting, aluminium foil or the like to catch swarf, debris, etc. and minimise its spread to other parts of the job.

Following each stage of such work, swarf, debris, etc., shall be cleaned up with a vacuum cleaner and surfaces wiped down with an IPA or laboratory grade ethanol using clean lint free rags.

If grinding is essential, the grinding wheel shall be free of organic components and shall have been manufactured in an oil-free, clean environment. Grinding wheels shall be *accepted* by IO prior to use.

5.3. Welding, Brazing & Soldering

All welding shall be to the requirements of the ITER Vacuum Handbook Attachment

1 [3]. Such operations shall only be carried out when specified in the WI. Only *accepted* weld fillers, brazing materials, solders and fluxes may be used.

Following each stage of such work, surfaces once cooled shall be wiped down with IPA or ethanol using clean lint-free rags and all traces of flux, etc., removed.

5.4. Mechanical Joining

Surfaces to be joined shall be cleaned by swabbing with IPA or laboratory grade ethanol on lint-free rags.

Only fasteners of the type specified in the WI and fabricated from *accepted* materials shall be used.

Unless specified in the WI, no lubricants, greases, thermal compounds, etc., shall be used on joints or fasteners.

5.5. Marking

Marking of any surface shall normally be carried out by scribing. The use of marker pens, ink, dyes, paint, etc., shall only be as specified in the WI. Only IO *accepted* marker pens, ink, dyes, paint, etc. shall be used.

6. Specific Requirements

To preserve cleanliness of the components and the area in which the components are assembled and/or integrated the requirements as specified in the following sections shall be satisfied. The requirements pertain to vacuum equipment after final cleaning.

6.1. Assembly and Integration

6.1.1. VQC 1 and 2 Demountable Joints

The making of demountable joints of flange class 1 [4] for use on VQC 1 equipment shall be under the supervision of the IO Vacuum Section. This requirement shall be stated in the WI. The ITER Vacuum Responsible Officer will nominate a representative of the IO Vacuum Section to supervise this activity.

6.1.2. Ex-Vessel

In the case where assembly operations are to be performed on a piece of vacuum equipment with exposed surfaces of different VQC (for e.g. VV sector) the more stringent

H

requirements for cleanliness shall apply to the whole piece.

6.1.2.1. VQC 1

Areas for the assembly of VQC 1 equipment shall be physically segregated from other work areas in the vicinity unless those work areas are of the same cleanliness (i.e. the room in which the clean area is to be established meets the cleanliness requirements *per se*).

The suitability of the clean area shall be checked on a regular basis (daily) by monitoring the airborne particulate count, which should not exceed 5×10^6 Particles of size $> 0.5 \mu\text{m}$ per m^3 . Should the daily air check return a particle count not in compliance with these limits specified herein the WRO shall be informed as soon as possible.

6.1.2.2. VQC 2

Areas for the assembly of VQC 2 equipment shall be maintained clean by daily cleaning of the working areas, including the floors and surfaces.

6.1.2.3. VQC 3 and 4

Areas for the assembly of VQC 3 and 4 equipment shall be kept clean by daily cleaning of the general area.

6.2. In-vessel

6.2.1. General

Personnel entering the inner area shall wear clean room clothing, comprising clean white overalls; overshoes or clean job specific footwear; protective hair nets or caps and beard covers where appropriate; powder free latex or nitrile outer gloves as specified in Section 4.3.

Personnel entry shall be through a controlled temporary vestibule with curtains screening the vessel entry aperture and the outer access from general areas. This vestibule shall be constructed so that it can be maintained in a clean and controlled manner. The vestibule shall be divided into two areas with a step over barrier between them. Each area will have sticky mats on the floor. The outer area will be for changing into clean room clothing.

Dedicated clean tools and equipment shall be stored in the inner area. Positive air flow shall be maintained from the inner to the outer area.

Only authorised personnel shall be permitted to enter the inner area.

No work shall be carried out by personnel who have not been trained for such work.

Where possible when working in the vessel, personnel shall stand on suitably supported temporary flooring manufactured from stainless steel or aluminium sheet covered with clean aluminium foil. Such foil shall be replaced at frequent intervals.

6.2.2. VQC 1

The requirements for cleanliness pertaining to in-vessel VQC 1 work areas shall be compliant with section 6.1.2 of this Attachment with the exception that the vacuum containment boundary may be considered a barrier for work area segregation.

6.2.3. Ventilation

6.2.3.1. VQC 1 & 2 ventilation air flow rate

Vacuum enclosures shall be ventilated with atmospheric air at a flow rate sufficient to provide at least 10 air changes per hour. The flow rate shall be determined on a case by case basis depending on the volume to be ventilated.

6.2.3.2. VQC 1 and 2 ventilation air humidity

Air for the ventilation of VQC 1 and vacuum enclosures shall have a relative humidity not exceeding 70%

6.2.3.3. Particulate count

Air for ventilation of VQC 1 enclosures shall have a maximum particulate count which shall not exceed 5×10^6 Particles of size $> 0.5 \mu\text{m}$ per m^3 measured at the vessel air inlet.

6.3. Work Areas in the Vicinity of VQC 1 and 2 Systems

All vessel apertures open to VQC 1 and / or 2 vacuum areas which are not directly involved in the work being undertaken shall where practical be covered by clean polyethylene sheeting or clean aluminium foil.

The region of the machine being worked on shall be screened by a polythene tent or similar. All surfaces inside this area shall be cleaned off before and after the process by vacuuming and swabbing with IPA or laboratory grade ethanol using clean lint-free rags.

All equipment shall be protected in such a way that no contamination can be transferred to vacuum surfaces.

Care shall be taken to ensure that no oils or greases (including finger grease) are rubbed into any surface which forms a vacuum boundary.

7. References

- [1] ITER Vacuum Handbook (ITER_D_2EZ9UM).
- [2] Appendix 4 Accepted Fluids (ITER_D_2ELN8N).
- [3] Attachment 1. Inspection and Qualification of Welded Joints (ITER_D_2FMM4B).

[4] ITER Vacuum Handbook Appendix 8 Flanges (ITER_D_2DJYQA).

Disclaimer:

The views and opinions expressed herein do not necessarily reflect those of the ITER Organization.

References

This ITER Technical Report may contain references to internal technical documents. These are accessible to ITER staff and External Collaborators included in the corresponding ITER Document Management (IDM) lists. If you are not included in these lists and need to access a specific technical document referenced in this report, please contact us at ITR.support@iter.org and your request will be considered, on a case by case basis, and in light of applicable ITER regulations.